

Stainless Steel Heat Exchangers

Heat Transfer Technology from Bowman



BOWMAN[®]
100 YEARS OF HEAT TRANSFER TECHNOLOGY

Stainless Steel Heat

A high quality solution for aggressive fluids

Bowman stainless steel shell and tube heat exchangers have been developed for applications where either a contaminated cooling medium, or aggressive fluids, such as chemicals, synthetic oils or refrigerants are to be cooled, where other grade materials would be unsuitable.

Compact design

Easily integrated into process pipework

Thermal calculations

Available quickly from our technical specialists

Premium quality

UK manufactured using 316L stainless steel throughout

Wide range

Suitable for cooling heat loads in excess of 800kW

Simple to maintain

Tubes can be cleaned without draining primary circuit

Single or 3 pass versions

Specific models available to suit flow requirements



Shell & Tube Design

Bowman stainless steel heat exchangers feature a tube stack that is fixed to the outer body of the unit together with specially designed baffles, which provide efficient heat transfer.

Range

The range comprises 21 standard sizes, with a choice of heat loads from 9 to 838kW and with water flows from 120 to over 1000 l/min. Maximum working pressure is 20 bar. Maximum working temperature is 200°C (oil) and 110°C (water).

Typical Performance

Type	Oil Cooling			Water Cooling			Weight
	Heat Dissipated	Oil (Shell)	Water (Tube)	Heat Dissipated	Water (Shell)	Water (Tube)	
	kW	l/min	l/min	kW	l/min	l/min	kg
SB4507-2	9	120	120	42	80	120	11
SB4507-4	15	110	85	61	70	85	15
SB4507-6	22	90	75	92	55	75	20
SC4508-4	22	180	140	111	120	180	21
SC4508-6	35	170	140	156	100	140	27
SC4508-8	48	150	120	200	95	120	38
SD4509-4	52	240	320	245	160	320	30
SD4509-6	82	210	250	361	130	250	45
SD4509-8	133	180	220	495	115	220	62
SE4510-4	66	480	460	301	310	460	44
SE4510-6	100	390	360	425	280	360	60
SE4510-8	144	330	310	570	220	310	78
SE4510-9	196	300	280	642	200	280	104
SF4511-4	140	580	740	600	420	740	79
SF4511-6	224	550	650	907	390	650	101
SF4511-8	354	500	520	1110	340	520	133
SF4511-9	536	460	480	1230	310	480	164
SG4512-4	223	960	1100	1020	700	1300	114
SG4512-6	358	920	1000	1390	650	1000	148
SG4512-8	624	740	900	2030	500	900	198
SG4512-9	871	750	790	2050	480	790	244

This table gives a general guide to standard (3 pass) heat exchanger performance cooling ISO 37 oil or water with an outlet temperature of 50°C with cooling water at an inlet temperature of 25°C. For single pass figures, contact our technical sales team on +44 (0) 121 359 5401.

Easy Product Selection

Computer aided software is used to select the correct heat exchanger for your application. Please contact Bowman, or your nearest stockist with the following information:

- Primary fluid details (water or oil properties)
- Primary fluid flow rate
- Required water or oil outlet temperature
- Heat to be dissipated
- Temperature and source of cooling water

Exchangers



Stainless Steel Construction

316L stainless steel is used throughout these heat exchangers, with 9.5mm tube for the tube stack providing efficient heat transfer.

Simple to Maintain

All models feature easily removable end covers, which give easy access to the tubes for cleaning. As the tube stack is fixed, all cleaning and maintenance requirements can be carried out without the need to drain the primary circuit.

Dimensions

Model	A	B	C	D	E	F	G	H	J	K	L	M
	mm	mm	mm	mm	mm	mm	mm	mm	mm	mm	BSP	BSP
SB4507-2	460	266	310	89	136	60	90	75	89	22	1"	1"
SB4507-4	734	540	584	89	136	60	90	75	89	22	1"	1"
SB4507-6	1114	920	964	89	136	60	90	75	89	22	1"	1"
SC4508-4	764	520	584	114	160	80	110	90	114	28	1 1/4"	1 1/4"
SC4508-6	1144	900	964	114	160	80	110	90	114	28	1 1/4"	1 1/4"
SC4508-8	1652	1408	1472	114	160	80	110	90	114	28	1 1/4"	1 1/4"
SD4509-4	764	510	584	141	194	100	130	105	141	35	1 1/2"	1 1/2"
SD4509-6	1134	890	964	141	194	100	130	105	141	35	1 1/2"	1 1/2"
SD4509-8	1652	1398	1472	141	194	100	130	105	141	35	1 1/2"	1 1/2"
SE4510-4	784	490	584	168	220	130	160	120	168	45	2"	2"
SE4510-6	1164	870	964	168	220	130	160	120	168	45	2"	2"
SE4510-8	1672	1378	1472	168	220	130	160	120	168	45	2"	2"
SE4510-9	2180	1886	1980	168	220	130	160	120	168	45	2"	2"
SF4511-4	834	470	574	219	284	180	220	150	219	60	2 1/2"	2 1/2"
SF4511-6	1214	850	954	219	284	180	220	150	219	60	2 1/2"	2 1/2"
SF4511-8	1722	1358	1462	219	284	180	220	150	219	60	2 1/2"	2 1/2"
SF4511-9	2230	1866	1970	219	284	180	220	150	219	60	2 1/2"	2 1/2"
SG4512-4	844	430	574	273	340	250	290	180	273	70	3"	3"
SG4512-6	1224	810	954	273	340	250	290	180	273	70	3"	3"
SG4512-8	1732	1318	1462	273	340	250	290	180	273	70	3"	3"
SG4512-9	2240	1826	1970	273	340	250	290	180	273	70	3"	3"

Dimensions shown are for 3 pass models. Contact our technical sales team for single pass dimensions.

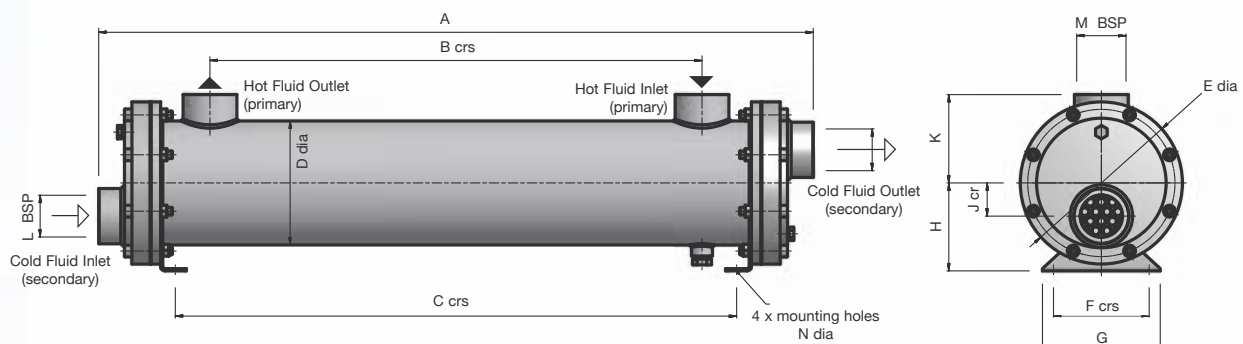

Quality

Bowman heat exchangers are renowned for quality and durability. Our stainless steel units are manufactured to ISO 9001:2015 and are proven in a wide range of applications, including food and beverage, biomass energy, oil and gas, paper and pulp, pharmaceutical and petrochemical industries.

Rapid Delivery

UK manufactured in our own production facility, we hold extensive stocks of the most popular models.

A world of applications

316L stainless steel used throughout the construction of these heat exchangers makes them suitable for a range of demanding applications, including chemical processing, paper & pulp production, refrigerants and synthetic oils. Here are a few examples:



Process Cooling

A series of Bowman stainless steel heat exchangers are used as part of a process cooling system for Siemens inverter drives at a UK power station, using river water as the cooling medium.



Automotive Engine Testing

One of the leading manufacturers of engine testing equipment has specified Bowman stainless steel heat exchangers for a major automotive testing company in China to meet the company's high specification demands.



Industrial Process Cleaning

A new process cleaning facility, incorporating a Bowman stainless steel heat exchanger, has been installed within the production facilities of this major UK based baking group, providing an efficient cleaning solution for bread trays.



All Bowman stainless steel heat exchangers are produced to the highest quality in our dedicated UK manufacturing centre to ISO 9001:2015 standards. With over 50 years' experience, you can have complete confidence when you specify Bowman stainless steel heat exchangers.

EJ Bowman (Birmingham) Ltd

Chester Street, Birmingham B6 4AP, UK

Tel: +44 (0) 121 359 5401

Fax: +44 (0) 121 359 7495

Email: sales@ej-bowman.com

www.ej-bowman.com

BOWMAN®

100 YEARS OF HEAT TRANSFER TECHNOLOGY

All material contained in this brochure is the intellectual property of EJ Bowman (Birmingham) Ltd. It is protected under copyright and may not be reproduced without prior written consent of the company. EJ Bowman (Birmingham) Ltd, reserve the right to change specifications without prior notice.

