

# Header Tank Heat Exchangers

Heat Transfer Technology from Bowman



**BOWMAN**<sup>®</sup>  
100 YEARS OF HEAT TRANSFER TECHNOLOGY

# Staying cool under

## Bowman Header Tank Heat Exchangers

For marine propulsion and stationary land based engine cooling

Bowman Header Tank heat exchangers are designed for cooling engines in applications where air cooling is either unavailable or inappropriate, due to the nature of the application.

For over 50 years, they have been used to cool engine jacket water, in applications as diverse as marine propulsion, CHP power generation systems, automotive engine testing and fire pumps used in emergency fire protection systems.

Efficient cooling is vital to the performance and operation of an engine and by installing Bowman Header Tank heat exchangers, the correct operating temperature can be consistently maintained.

They also offer a more compact cooling solution to traditional air blast radiators, aiding engine packaging when available space is at a premium.



### Unique design

To increase thermal performance all Bowman Header Tank heat exchangers feature a unique 'quiet zone' design with a special de-aeration feature and pressurised filler cap.

### Reliable operation

The 'quiet zone' and large reservoir area above the tube stack eliminates the problem of air pockets or air locks getting into the coolant stream, improving operational reliability.

### Fully floating tube stack

The 'fully floating' design allows expansion and contraction of the tube stack within the cast body of the heat exchanger, which minimises thermal stress, enhancing reliability and longevity.

### Simple to maintain

The easily removable tube stack and end covers make cleaning and routine maintenance procedures simple and straightforward.

### Wide range

Bowman provide the most comprehensive range of Header Tank heat exchangers available. On the coolant side, there is a choice of single, double or triple pass units to suit different flow rates.

### Marine and land based versions

Whether the cooling medium is salt water, fresh water, or mineral rich/contaminated water, Bowman has a range of Header Tank heat exchangers to suit any marine or land based application.

### Titanium tube stacks

Titanium is the ultimate 'fit and forget' material for applications where aggressive water conditions exist. Bowman now offer titanium tube stacks on many of our Header Tank header exchangers. See page 11 for more details.





# pressure



© Jan Berghuis-Terschelling

## Easy product selection

At Bowman, we have developed a computer programme to select the correct Header Tank heat exchanger for your application. Simply by supplying us with the following information we can advise the correct unit;

- 1: Heat to be dissipated in kW
- 2: Engine water flow rate in l/min
- 3: Max. engine water temperature in °C
- 4: Cooling water temperature in °C
- 5: Type of cooling water to be used (sea water, fresh water or contaminated water)

## Bespoke designs for specific engines

We have a number of heat exchangers that have been designed for specific engines. You can find more information on these units by calling our technical sales team on +44 (0) 121 359 5401.

## Jacket water connection

All units are supplied with either hose adaptors or counter flange plates for connecting the engine jacket water inlet and outlet. Please see page 14 for more details.



## Marine Header Tank Heat Exchangers

Bowman's range of marine grade Header Tank heat exchangers is specially designed to operate with aggressive cooling media such as sea water or mineral rich fresh water. The specification of these units includes cupronickel tube stacks, plus corrosion-resistant end covers, to ensure long-life reliability in the harshest operating conditions.



Unit shown is fitted with the optional Murphy Level Switch.

© Jan Berghuis-Terschelling

Single Pass Marine		Two Pass Marine		Three Pass Marine	
Type	Max Raw Water Flow l/min	Type	Max Raw Water Flow l/min	Type	Max Raw Water Flow l/min
EH100-4965-2	180	EH100-4165-2	60	EH100-3401-2	54
EH200-4965-3	180	EH200-4165-3	60	EH200-3401-3	54
FH100-4966-2	270	FH100-4166-2	100	FH100-3182-2	95
FH200-4966-3	270	FH200-4166-3	100	FH200-3182-3	95
FH300-4967-2	375	FH300-4167-2	140	FH300-3282-2	125
FH400-4967-3	375	FH400-4167-3	140	FH400-3282-3	125
GH200-4968-2*	640	GH200-4168-2*	240	GH200-3482-2*	225
GH300-4968-3*	640	GH300-4168-3*	240	GH300-3482-3*	225
GH400-4968-4*	640	GH400-4168-4*	240	GH400-3482-4*	225
KH200-4969-3*	975	KH200-4169-3*	400	KH200-3071-3*	325
KH300-4969-4*	975	KH300-4169-4*	400	KH300-3071-4*	325
KH400-4969-5*	975	KH400-4169-5*	400	KH400-3071-5*	325
JH200-4970-3*	1400	JH200-4170-3*	540	JH200-3335-3*	460
JH300-4970-4*	1400	JH300-4170-4*	540	JH300-3335-4*	460
JH400-4970-5*	1400	JH400-4170-5*	540	JH400-3335-5*	460
PH200-4971-4*	2125	PH200-4171-4*	820	PH200-3073-4*	700
PH300-4971-5*	2125	PH300-4171-5*	820	PH300-3073-5*	700
PH400-4971-6*	2125	PH400-4171-6*	820	PH400-3073-6*	700

\*A Murphy Level Switch can be fitted to these units, at extra cost, to indicate low water level conditions.



## Land based Header Tank Heat Exchangers

For land based cooling applications, where fresh or contaminated water is used as the cooling medium, Bowman Header Tank heat exchangers have cupro-nickel tube stacks with cast iron end covers as standard. For applications where clean, mains water is used, such as fire pumps, copper tube stacks are also available, offering a cost-effective alternative provided there are no contaminants in the water.



*Irrigation pump sets being cooled by Bowman Header Tank heat exchangers in Australia*



Single pass Land		Three pass Land	
Type	Max Raw Water Flow l/min	Type	Max Raw Water Flow l/min
EH100-4265-2	180	EH100-4065-2	60
EH200-4265-3	180	EH200-4065-3	60
FH100-4266-2	270	FH100-4066-2	100
FH200-4266-3	270	FH200-4066-3	100
FH300-4267-2	375	FH300-4067-2	140
FH400-4267-3	375	FH400-4067-3	140
GH200-4268-2*	640	GH200-4068-2*	240
GH300-4268-3*	640	GH300-4068-3*	240
GH400-4268-4*	640	GH400-4068-4*	240
KH200-4269-3*	975	KH200-4069-3*	400
KH300-4269-4*	975	KH300-4069-4*	400
KH400-4269-5*	975	KH400-4069-5*	400
JH200-4270-3*	1400	JH200-4070-3*	540
JH300-4270-4*	1400	JH300-4070-4*	540
JH400-4270-5*	1400	JH400-4070-5*	540
PH200-4271-4*	2125	PH200-4071-4*	820
PH300-4271-5*	2125	PH300-4071-5*	820
PH400-4271-6*	2125	PH400-4071-6*	820

For units with copper tubes, add suffix 'TC' to type number.

\*A Murphy Level Switch can be fitted to these units, at extra cost, to indicate low water level conditions.

## The Complete Header Tank Range

The range of Bowman Header Tank heat exchangers showing their power ratings, various water volumes and our equivalent non-header tank tubular heat exchangers.



Type	Typical Engine Suitability		Raw Water Volume	Engine Water Volume	Header Tank Capacity	Tubular Heat Exchangers*
	KW	HP	Litres	Litres	Litres	
EH100	40	54	0.45	1.30	0.90	EC100*
EH200	52	70	0.60	2.20	1.32	EC120*
FH100	82	110	0.85	3.25	2.08	FC100*
FH200	115	154	1.10	4.50	2.93	FC120*
FH300	150	201	1.55	6.55	4.12	FG100*
FH400	200	270	2.00	9.15	5.70	FG120*
GH200	240	322	3.10	10.90	6.20	GL140*
GH300	320	429	3.80	14.85	8.54	GL180*
GH400	400	540	4.60	18.10	11.20	-
KH200	450	603	6.30	18.80	13.00	GK190*
KH300	600	804	7.50	25.60	17.30	GK250*
KH400	750	1005	9.00	33.50	22.60	-
JH200	620	831	8.80	27.20	18.60	JK190*
JH300	820	1100	10.40	36.90	24.80	JK250*
JH400	1000	1340	12.50	46.30	32.30	-
PH200	1200	1608	18.60	49.00	34.20	PK250*
PH300	1500	2010	21.80	64.00	44.60	PK320*
PH400	1800	2413	25.30	81.00	56.40	-

Maximum working raw water pressure 16 bar

Maximum working engine water pressure 1 bar (depending on the filler cap rating)

Maximum working temperature 110°C

\* This column shows the equivalent tubular heat exchangers. If this type is required instead of a Header Tank heat exchanger, please contact us for further details.

# EH Range

Three Pass Version

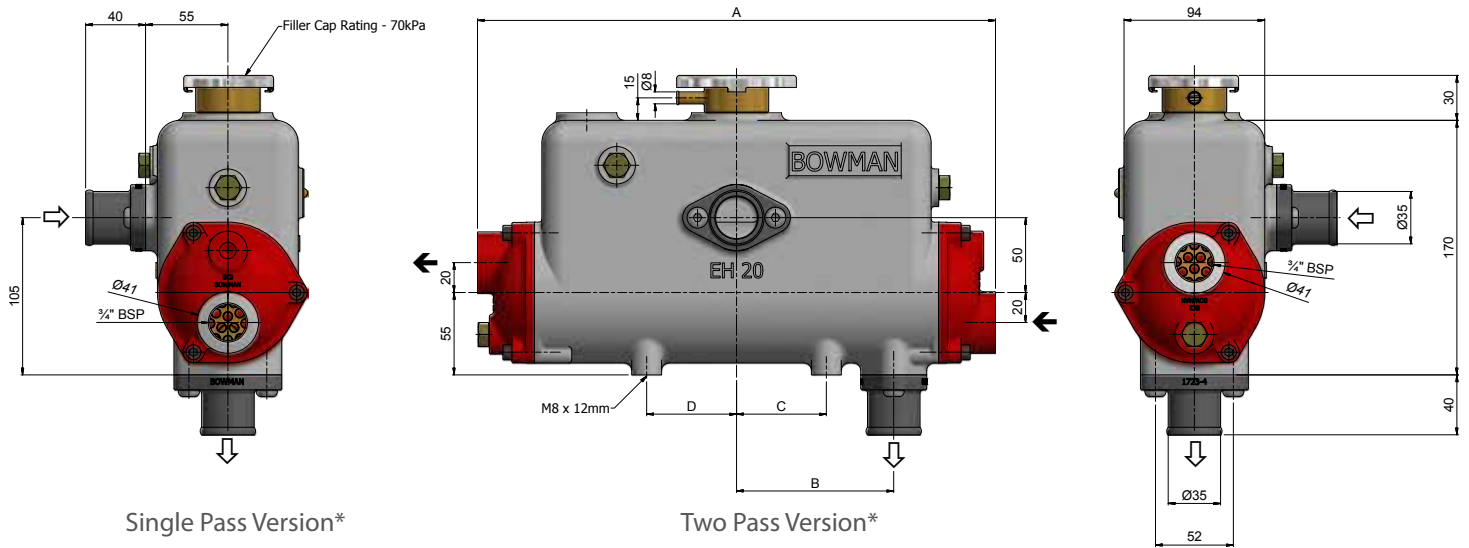

Single Pass Version\*

Two Pass Version\*

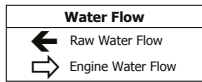
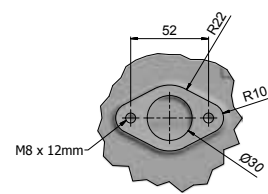
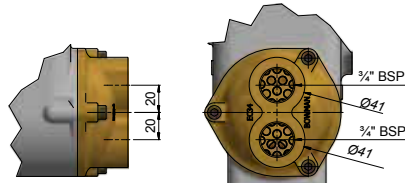
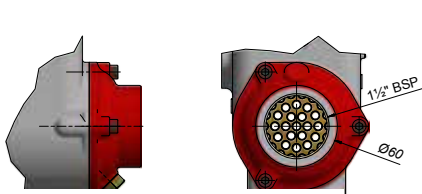

Type	Weight	A	B	C	D
EH100	5kg	260mm	62mm	20mm	60mm
EH200	6kg	346mm	105mm	60mm	60mm

Engine Water Inlet & Outlet Flange Detail Without Hose Adaptor

# FH Range

Three Pass Version

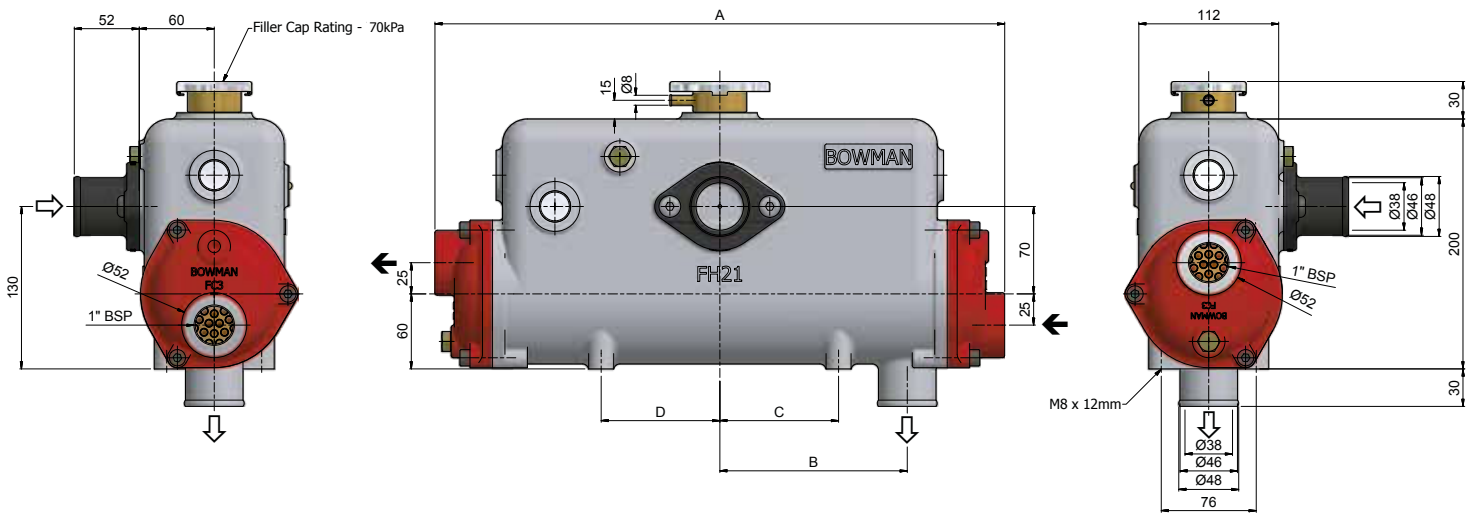

Single Pass Version\*

Two Pass Version\*

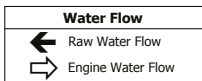
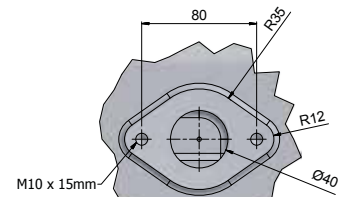
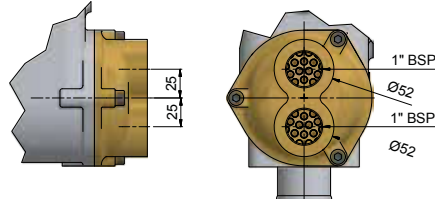
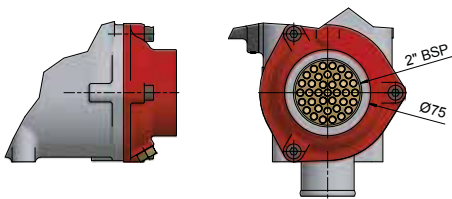

Type	Weight	A	B	C	D
FH100	8kg	358mm	100mm	45mm	95mm
FH200	11kg	454mm	150mm	95mm	95mm

Engine Water Inlet Flange Detail Without Hose Adaptor

\* These units are available at extra cost and with slightly longer lead times.

# FH Range continued

## Three Pass Version

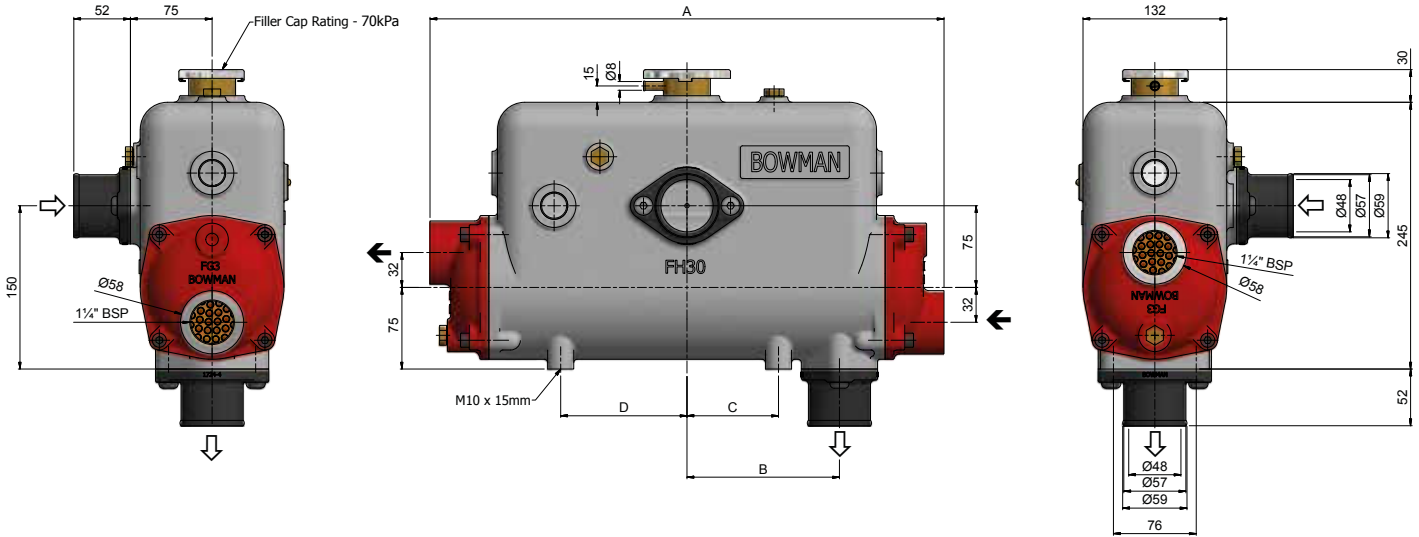

Single Pass Version\*

Two Pass Version\*

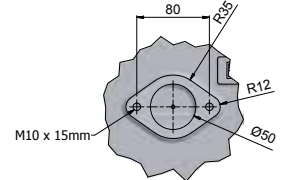
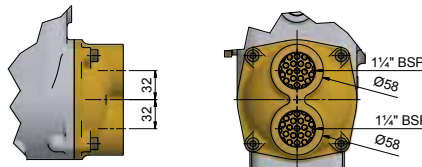
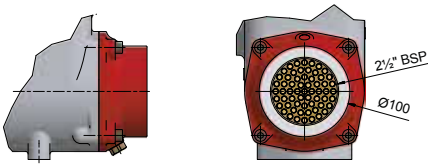

Engine Water Inlet & Outlet Flange Detail Without Hose Adaptor

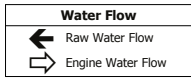

Type	Weight	A	B	C	D
FH300	14kg	472mm	140mm	84mm	116mm
FH400	17kg	600mm	200mm	144mm	144mm

# GH Range

## Three Pass Version

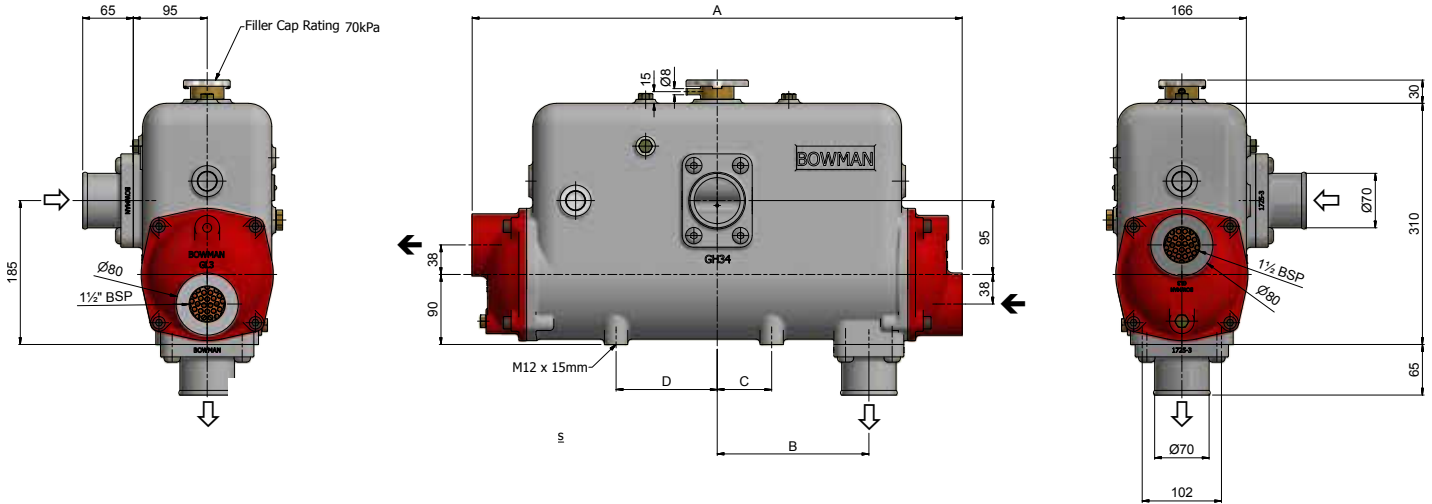

Single Pass Version\*

Two Pass Version\*

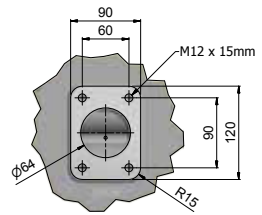
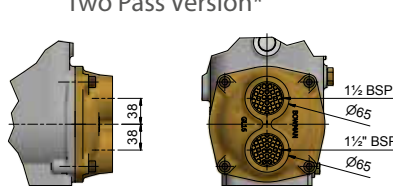
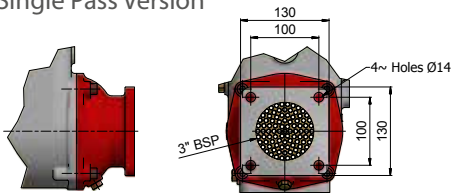

Engine Water Inlet & Outlet Flange Detail Without Hose Adaptor

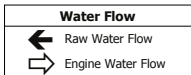

Type	Weight	A	B	C	D
GH200	25kg	502mm	135mm	70mm	130mm
GH300	30kg	630mm	195mm	70mm	130mm
GH400	35kg	776mm	270mm	146mm	200mm

\* These units are available at extra cost and with slightly longer lead times.



# KH Range

## Three Pass Version

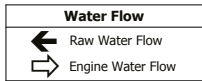
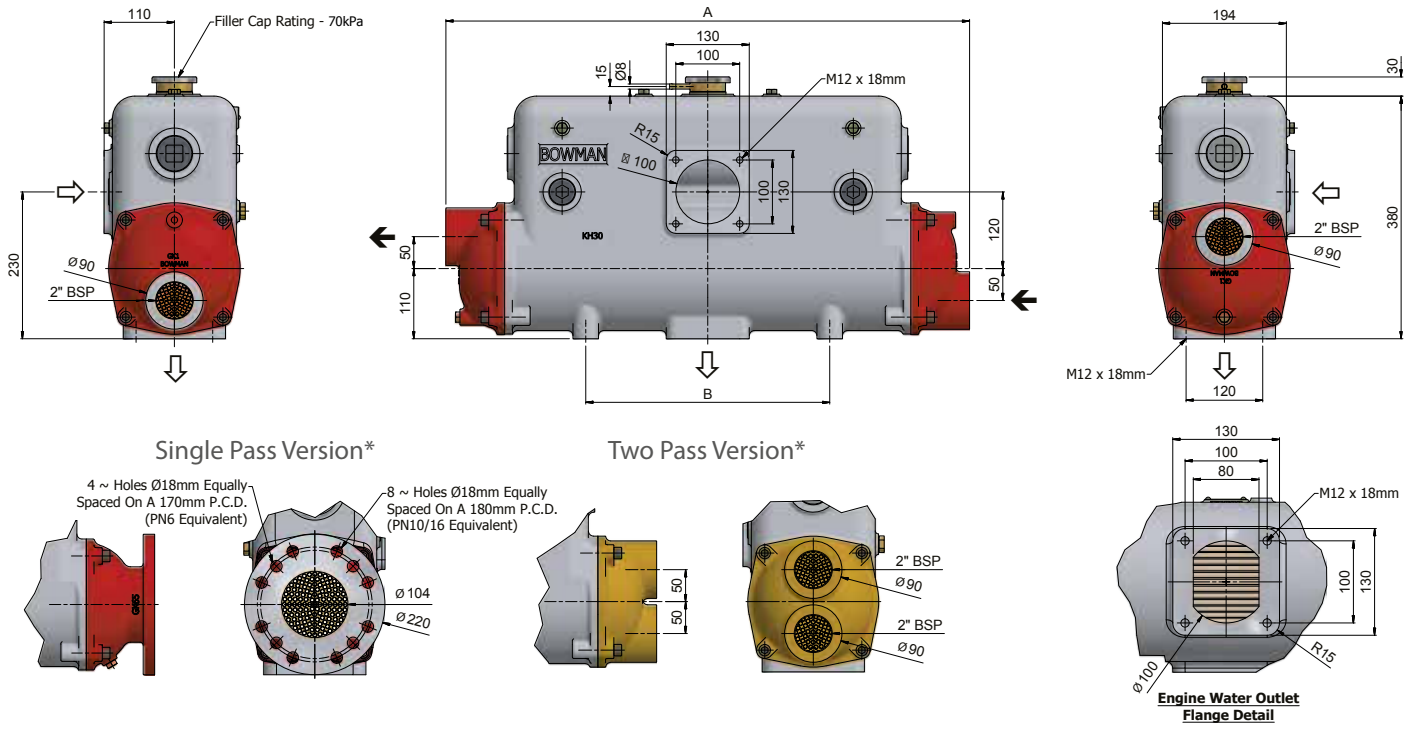

Type	Weight	A	B
KH200	51kg	674mm	382mm
KH300	59kg	820mm	382mm
KH400	67kg	998mm	560mm

# JH Range

## Three Pass Version

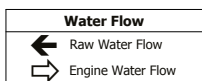
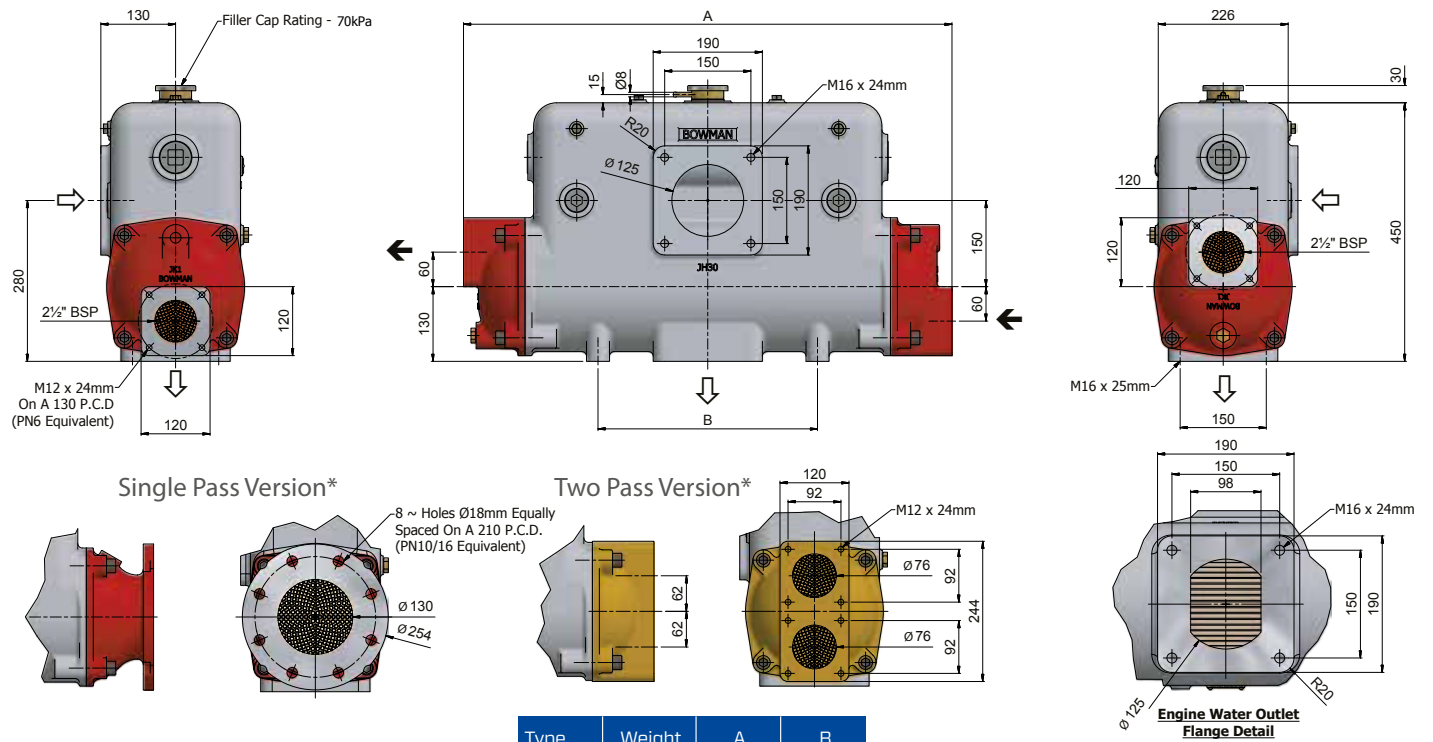

Type	Weight	A	B
JH200	82kg	704mm	382mm
JH300	93kg	850mm	382mm
JH400	106kg	1028mm	560mm

\* These units are available at extra cost and with slightly longer lead times.

# PH Range

Three Pass Version

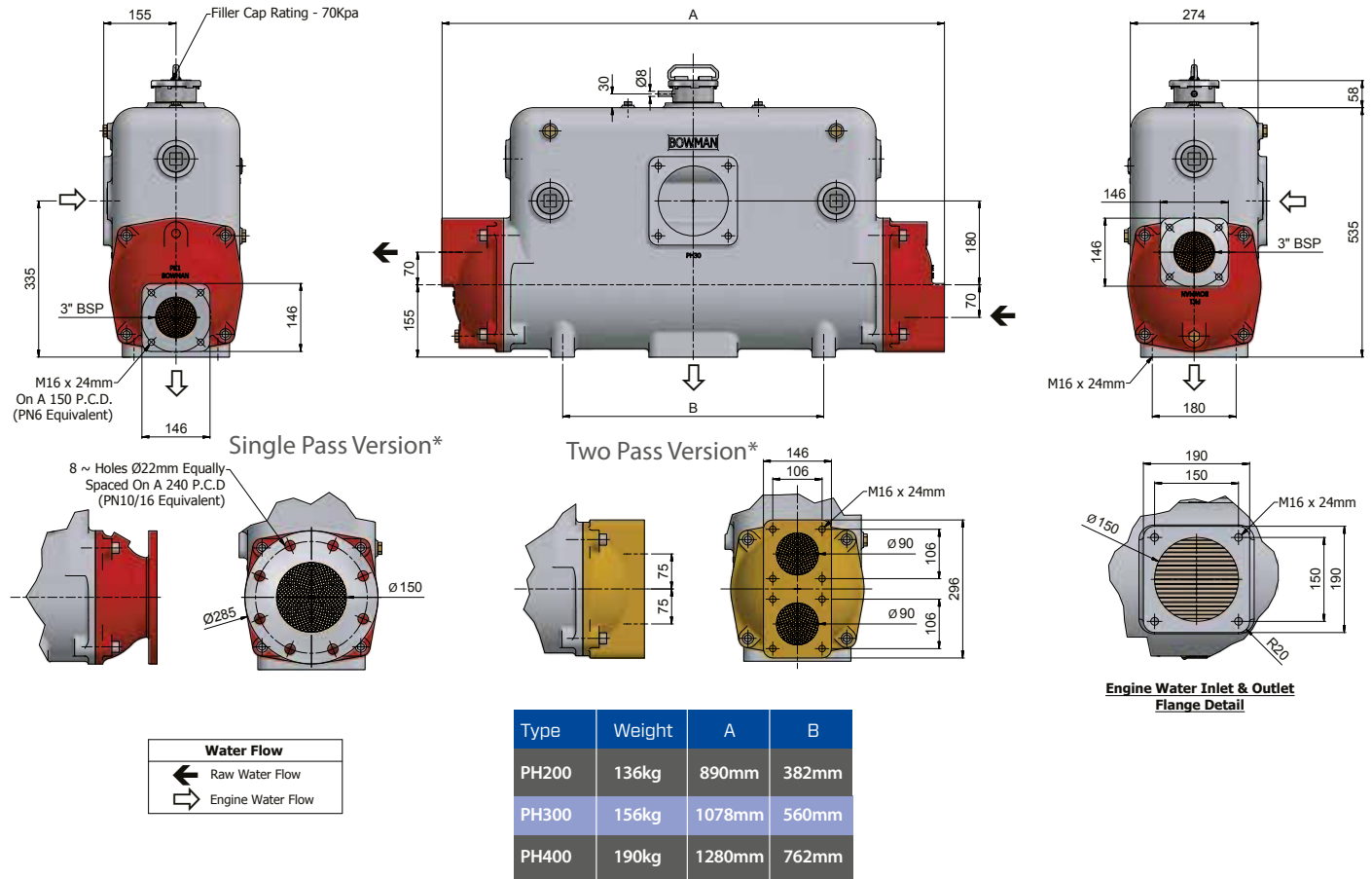

\* These units are available at extra cost and with slightly longer lead times.

## Three, Two and Single Pass Heat Exchangers

### Three pass

Three pass units transfer more heat from a given water flow, splitting the internal area of the tube stack into three separate sections. Cooling water passes through the first third of the tubes, is redirected for a second pass through the middle tube section before redirection to the third pass, exiting the tubes via the upper connection.

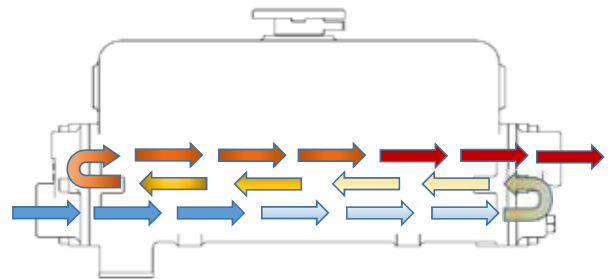

### Two pass\*

Ideal for installations where access or space is limited as the cooling water enters and leaves the unit from the same side, simplifying pipework requirements. Two pass units can also accommodate higher flow rates than three pass units.

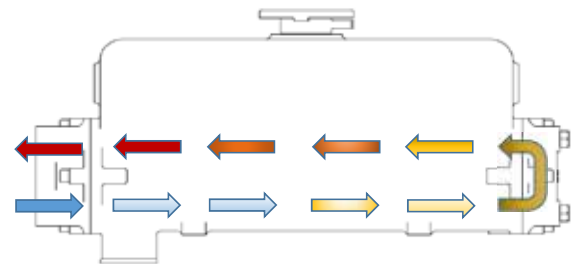

### Single pass\*

These units are suitable for applications where the cooling water flow rate is unavoidably high, as water passes through the whole tube stack in a single pass.

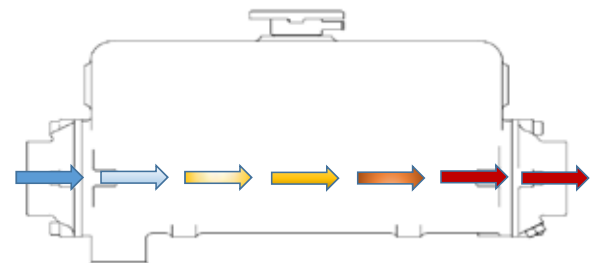

# BOWMAN®

## Land-Based 3-Pass Header Tank Replacement Parts

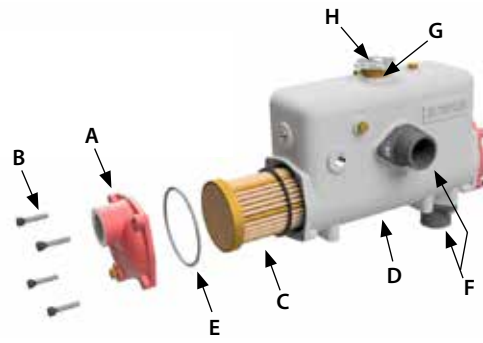

Type	(A) End Covers	(B) Socket Screws	(C) Tube Stack	(D) Body	(E) O' Seals	(F) Hose Adaptor Kit (No. Off Per Kit)	Counter Flange Kit (No. Off Per Kit)	(G) Filler Neck Assembly	(H) Filler Cap (kPa Rating)
EH100-4065-2	EC33-1040CI / -DR	HS06X30DP	5088-2TN1P	EH10-3403-2AL	AN12NT	1723-4 (2)	1783-2 (2)	3921-1	2753 (70)
EH200-4065-3	EC33-1040CI / -DR	HS06X30DP	5088-3TN1P	EH12-3403-3AL	AN12NT	1723-4 (2)	1783-2 (2)	3921-1	2753 (70)
FH100-4066-2	FC3-1281CI / -DR	HS08X35DP	5089-2TN1P	FH11-3172-2AL	OS46NT	1724-2 (1)	1783-3 (1)	3921-1	2753 (70)
FH200-4066-3	FC3-1281CI / -DR	HS08X35DP	5089-3TN1P	FH21-3172-3AL	OS46NT	1724-2 (1)	1783-3 (1)	3921-1	2753 (70)
FH300-4067-2	FG3-1583CI / -DR	HS08X35DP	5090-2TN1P	FH30-3276-2AL	OS52NT	1724-4 (2)	1783-3 (2)	3921-1	2753 (70)
FH400-4067-3	FG3-1583CI / -DR	HS08X35DP	5090-3TN1P	FH46-3276-3AL	OS52NT	1724-4 (2)	1783-3 (2)	3921-1	2753 (70)
GH200-4068-2	GL3-3141CI / -DR	HS10X40DP	3447-2TN1B	GH29-3433-2AL	OS63NT	1725-3 (2)	1783-4 (2)	3921-1	2753 (70)
GH300-4068-3	GL3-3141CI / -DR	HS10X40DP	3447-3TN1B	GH34-3433-3AL	OS63NT	1725-3 (2)	1783-4 (2)	3921-1	2753 (70)
GH400-4068-4	GL3-3141CI / -DR	HS10X40DP	3447-4TN1B	GH36-3433-4AL	OS63NT	1725-3 (2)	1783-4 (2)	3921-1	2753 (70)
KH200-4069-3	GK1-2864CI / -DR	HS12X50DP	4048-3TN1B	KH20-3072-3AL	OS69NT	N/A	1783-5 (2)	3921-2	2748 (70)
KH300-4069-4	GK1-2864CI / -DR	HS12X50DP	4048-4TN1B	KH30-3072-4AL	OS69NT	N/A	1783-5 (2)	3921-2	2748 (70)
KH400-4069-5	GK1-2864CI / -DR	HS12X50DP	4048-5TN1B	KH40-3072-5AL	OS69NT	N/A	1783-5 (2)	3921-2	2748 (70)
JH200-4070-3	JK1-3333CI / -DR	HS16X70DP	4049-3TN1B	JH20-3330-3AL	OS74NT	N/A	1783-6 (2)	3921-2	2748 (70)
JH300-4070-4	JK1-3333CI / -DR	HS16X70DP	4049-4TN1B	JH30-3330-4AL	OS74NT	N/A	1783-6 (2)	3921-2	2748 (70)
JH400-4070-5	JK1-3333CI / -DR	HS16X70DP	4049-5TN1B	JH40-3330-5AL	OS74NT	N/A	1783-6 (2)	3921-2	2748 (70)
PH200-4071-4	PK1-2918CI / -DR	HS16X65DP	4050-4TN1B	PH20-3074-4AL	OS81NT	N/A	1783-6 9 (2)	3921-3	3054 (50)
PH300-4071-5	PK1-2918CI / -DR	HS16X65DP	4050-5TN1B	PH30-3074-5AL	OS81NT	N/A	1783-6 (2)	3921-3	3054 (50)
PH400-4071-6	PK1-2918CI / -DR	HS16X65DP	4050-6TN1B	PH40-3074-6AL	OS81NT	N/A	1783-6 9 (2)	3921-3	3054 (50)

## Marine-Based 3-Pass Header Tank Replacement Parts

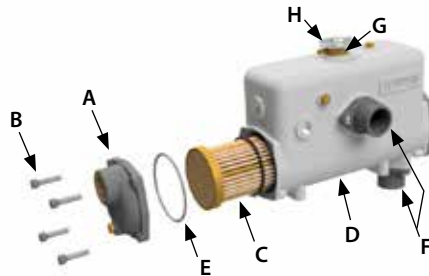

Type	(A) End Covers	(B) Socket Screws	(C) Tube Stack	(D) Body	(E) O' Seals	(F) Hose Adaptor Kit (No. Off Per Kit)	Counter Flange Kit (No. Off Per Kit)	(G) Filler Neck Assembly	(H) Filler Cap (kPa Rating)
EH100-3401-2	EC3C-5480 / -DR	HS06X30DP	5088-2TN1P	EH10-3403-2AL	AN12NT	1723-4 (2)	1783-2 (2)	3921-1	2753 (70)
EH200-3401-3	EC3C-5480 / -DR	HS06X30DP	5088-3TN1P	EH12-3403-3AL	AN12NT	1723-4 (2)	1783-2 (2)	3921-1	2753 (70)
FH100-3182-2	FC3C-5481 / -DR	HS08X35DP	5089-2TN1P	FH11-3172-2AL	OS46NT	1724-2 (1)	1783-3 (1)	3921-1	2753 (70)
FH200-3182-3	FC3C-5481 / -DR	HS08X35DP	5089-3TN1P	FH21-3172-3AL	OS46NT	1724-2 (1)	1783-3 (1)	3921-1	2753 (70)
FH300-3282-2	FG3C-5482 / -DR	HS08X35DP	5090-2TN1P	FH30-3276-2AL	OS52NT	1724-4 (2)	1783-3 (2)	3921-1	2753 (70)
FH400-3282-3	FG3C-5482 / -DR	HS08X35DP	5090-3TN1P	FH46-3276-3AL	OS52NT	1724-4 (2)	1783-3 (2)	3921-1	2753 (70)
GH200-3482-2	GL3C-5483 / -DR	HS10X40DP	3447-2TN1B	GH29-3433-2AL	OS63NT	1725-3 (2)	1783-4 (2)	3921-1	2753 (70)
GH300-3482-3	GL3C-5483 / -DR	HS10X40DP	3447-3TN1B	GH34-3433-3AL	OS63NT	1725-3 (2)	1783-4 (2)	3921-1	2753 (70)
GH400-3482-4	GL3C-5483 / -DR	HS10X40DP	3447-4TN1B	GH36-3433-4AL	OS63NT	1725-3 (2)	1783-4 (2)	3921-1	2753 (70)
KH200-3071-3	GK1-2864BR / -DR	HS12X50DP	4048-3TN1B	KH20-3072-3AL	OS69NT	N/A	1783-5 (2)	3921-2	2748 (70)
KH300-3071-4	GK1-2864BR / -DR	HS12X50DP	4048-4TN1B	KH30-3072-4AL	OS69NT	N/A	1783-5 (2)	3921-2	2748 (70)
KH400-3071-5	GK1-2864BR / -DR	HS12X50DP	4048-5TN1B	KH40-3072-5AL	OS69NT	N/A	1783-5 (2)	3921-2	2748 (70)
JH200-3335-3	JK1-4353BR / -DR	HS16X70DP	4049-3TN1B	JH20-3330-3AL	OS74NT	N/A	1783-6 (2)	3921-2	2748 (70)
JH300-3335-4	JK1-4353BR / -DR	HS16X70DP	4049-4TN1B	JH30-3330-4AL	OS74NT	N/A	1783-6 (2)	3921-2	2748 (70)
JH400-3335-5	JK1-4353BR / -DR	HS16X70DP	4049-5TN1B	JH40-3330-5AL	OS74NT	N/A	1783-6 (2)	3921-2	2748 (70)
PH200-3073-4	PK1-4352BR / -DR	HS16X65DP	4050-4TN1B	PH20-3074-4AL	OS81NT	N/A	1783-6 (2)	3921-3	3054 (50)
PH300-3073-5	PK1-4352BR / -DR	HS16X65DP	4050-5TN1B	PH30-3074-5AL	OS81NT	N/A	1783-6 (2)	3921-3	3054 (50)
PH400-3073-6	PK1-4352BR / -DR	HS16X65DP	4050-6TN1B	PH40-3074-6AL	OS81NT	N/A	1783-6 (2)	3921-3	3054 (50)



## Land-Based 1-Pass Header Tank Replacement Parts

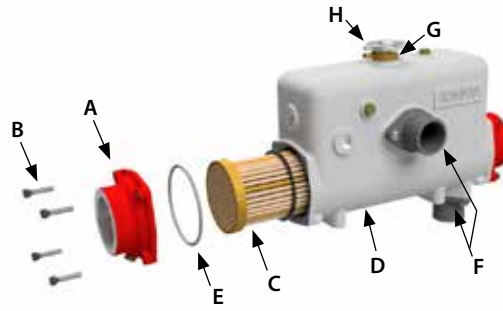

Type	(A) End Covers	(B) Socket Screws	(C) Tube Stack	(D) Body	(E) O' Seals	(F) Hose Adaptor Kit (No. Off Per Kit)	Counter Flange Kit (No. Off Per Kit)	(G) Filler Neck Assembly	(H) Filler Cap (kPa Rating)
EH100-4265-2	EC33-784CI / -DR	HS06X30DP	5088-2TN1P	EH10-3403-2AL	AN12NT	1723-4 (2)	1783-2 (2)	3921-1	2753 (70)
EH200-4265-3	EC33-784CI / -DR	HS06X30DP	5088-3TN1P	EH12-3403-3AL	AN12NT	1723-4 (2)	1783-2 (2)	3921-1	2753 (70)
FH100-4266-2	FC33-1176CI / -DR	HS08X35DP	5089-2TN1P	FH11-3172-2AL	OS46NT	1724-2 (1)	1783-3 (1)	3921-1	2753 (70)
FH200-4266-3	FC33-1176CI / -DR	HS08X35DP	5089-3TN1P	FH21-3172-3AL	OS46NT	1724-2 (1)	1783-3 (1)	3921-1	2753 (70)
FH300-4267-2	FG7-2802CI / -DR	HS08X35DP	5090-2TN1P	FH30-3276-2AL	OS52NT	1724-4 (2)	1783-3 (2)	3921-1	2753 (70)
FH400-4267-3	FG7-2802CI / -DR	HS08X35DP	5090-3TN1P	FH46-3276-3AL	OS52NT	1724-4 (2)	1783-3 (2)	3921-1	2753 (70)
GH200-4268-2	GL37-3140CI / -DR	HS10X40DP	3447-2TN1B	GH29-3433-2AL	OS63NT	1725-3 (1)	1783-4 (2)	3921-1	2753 (70)
GH300-4268-3	GL37-3140CI / -DR	HS10X40DP	3447-3TN1B	GH34-3433-3AL	OS63NT	1725-3 (1)	1783-4 (2)	3921-1	2753 (70)
GH400-4268-4	GL37-3140CI / -DR	HS10X40DP	3447-4TN1B	GH36-3433-4AL	OS63NT	1725-3 (1)	1783-4 (2)	3921-1	2753 (70)
KH200-4269-3	GK63-3255CI / -DR	HS12X50DP	4048-3TN1B	KH20-3072-3AL	OS69NT	N/A	1783-5 (2)	3921-2	2748 (70)
KH300-4269-4	GK63-3255CI / -DR	HS12X50DP	4048-4TN1B	KH30-3072-4AL	OS69NT	N/A	1783-5 (2)	3921-2	2748 (70)
KH400-4269-5	GK63-3255CI / -DR	HS12X50DP	4048-5TN1B	KH40-3072-5AL	OS69NT	N/A	1783-5 (2)	3921-2	2748 (70)
JH200-4270-3	JK4-3331CI / -DR	HS16X70DP	4049-3TN1B	JH20-3330-3AL	OS74NT	N/A	1783-6 (2)	3921-2	2748 (70)
JH300-4270-4	JK4-3331CI / -DR	HS16X70DP	4049-4TN1B	JH30-3330-4AL	OS74NT	N/A	1783-6 (2)	3921-2	2748 (70)
JH400-4270-5	JK4-3331CI / -DR	HS16X70DP	4049-5TN1B	JH40-3330-5AL	OS74NT	N/A	1783-6 (2)	3921-2	2748 (70)
PH200-4271-4	PK4-2926CIC / -DR	HS16X65DP	4050-4TN1B	PH20-3074-4AL	OS81NT	N/A	1783-6 (2)	3921-3	3054 (50)
PH300-4271-5	PK4-2926CIC / -DR	HS16X65DP	4050-5TN1B	PH30-3074-5AL	OS81NT	N/A	1783-6 (2)	3921-3	3054 (50)
PH400-4271-6	PK4-2926CIC / -DR	HS16X65DP	4050-6TN1B	PH40-3074-6AL	OS81NT	N/A	1783-6 (2)	3921-3	3054 (50)

## Marine-Based 1-Pass Header Tank Replacement Parts

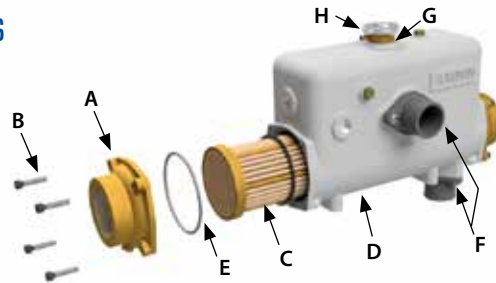

Type	(A) End Covers	(B) Socket Screws	(C) Tube Stack	(D) Body	(E) O' Seals	(F) Hose Adaptor Kit (No. Off Per Kit)	Counter Flange Kit (No. Off Per Kit)	(G) Filler Neck Assembly	(H) Filler Cap (kPa Rating)
EH100-4965-2	EC33-784BR / -DR	HS06X30DP	5088-2TN1P	EH10-3403-2AL	AN12NT	1723-4 (2)	1783-2 (2)	3921-1	2753 (70)
EH200-4965-3	EC33-784BR / -DR	HS06X30DP	5088-3TN1P	EH12-3403-3AL	AN12NT	1723-4 (2)	1783-2 (2)	3921-1	2753 (70)
FH100-4966-2	FC33-1176BR / -DR	HS08X35DP	5089-2TN1P	FH11-3172-2AL	OS46NT	1724-2 (1)	1783-3 (1)	3921-1	2753 (70)
FH200-4966-3	FC33-1176BR / -DR	HS08X35DP	5089-3TN1P	FH21-3172-3AL	OS46NT	1724-2 (1)	1783-3 (1)	3921-1	2753 (70)
FH300-4967-2	FG7-2802BR / -DR	HS08X35DP	5090-2TN1P	FH30-3276-2AL	OS52NT	1724-4 (2)	1783-3 (2)	3921-1	2753 (70)
FH400-4967-3	FG7-2802BR / -DR	HS08X35DP	5090-3TN1P	FH46-3276-3AL	OS52NT	1724-4 (2)	1783-3 (2)	3921-1	2753 (70)
GH200-4968-2	GL37-3140GM / -DR	HS10X40DP	3447-2TN1B	GH29-3433-2AL	OS63NT	1725-3 (1)	1783-4 (2)	3921-1	2753 (70)
GH300-4968-3	GL37-3140GM / -DR	HS10X40DP	3447-3TN1B	GH34-3433-3AL	OS63NT	1725-3 (1)	1783-4 (2)	3921-1	2753 (70)
GH400-4968-4	GL37-3140GM / -DR	HS10X40DP	3447-4TN1B	GH36-3433-4AL	OS63NT	1725-3 (1)	1783-4 (2)	3921-1	2753 (70)
KH200-4969-3	GK65-5255GM / -DR	HS12X50DP	4048-3TN1B	KH20-3072-3AL	OS69NT	N/A	1783-5 (2)	3921-2	2748 (70)
KH300-4969-4	GK65-5255GM / -DR	HS12X50DP	4048-4TN1B	KH30-3072-4AL	OS69NT	N/A	1783-5 (2)	3921-2	2748 (70)
KH400-4969-5	GK65-5255GM / -DR	HS12X50DP	4048-5TN1B	KH40-3072-5AL	OS69NT	N/A	1783-5 (2)	3921-2	2748 (70)
JH200-4970-3	JK4-3331GM / -DR	HS16X70DP	4049-3TN1B	JH20-3330-3AL	OS74NT	N/A	1783-6 (2)	3921-2	2748 (70)
JH300-4970-4	JK4-3331GM / -DR	HS16X70DP	4049-4TN1B	JH30-3330-4AL	OS74NT	N/A	1783-6 (2)	3921-2	2748 (70)
JH400-4970-5	JK4-3331GM / -DR	HS16X70DP	4049-5TN1B	JH40-3330-5AL	OS74NT	N/A	1783-6 (2)	3921-2	2748 (70)
PH200-4971-4	PK4-2926GM-DR	HS16X65DP	4050-4TN1B	PH20-3074-4AL	OS81NT	N/A	1783-6 (2)	3921-3	3054 (50)
PH300-4971-5	PK4-2926GM-DR	HS16X65DP	4050-5TN1B	PH30-3074-5AL	OS81NT	N/A	1783-6 (2)	3921-3	3054 (50)
PH400-4971-6	PK4-2926GM-DR	HS16X65DP	4050-6TN1B	PH40-3074-6AL	OS81NT	N/A	1783-6 (2)	3921-3	3054 (50)

## 2-Pass Header Tank Replacement Parts (Marine Specification Only)

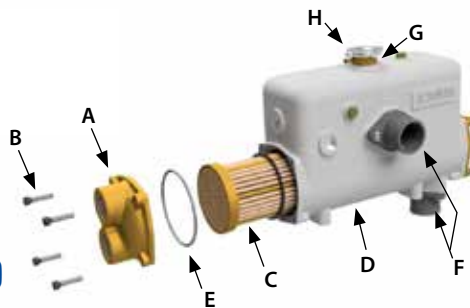

Type	(A) End Covers	(B) Socket Screws	(C) Tube Stack	(D) Body	(E) O' Seals	(F) Hose Adaptor Kit (No. Off Per Kit)	Counter Flange Kit (No. Off Per Kit)	(G) Filler Neck Assembly	(H) Filler Cap (kPa Rating)
EH100-4165-2	(2P) EC34-3631NB (BL) EC35-3632N	HS06X30DP	5088-2TN1P	EH10-3403-2AL	AN12NT	1723-4 (2)	1783-2 (2)	3921-1	2753 (70)
EH200-4165-3	(2P) EC34-3631NB (BL) EC35-3632NB	HS06X30DP	5088-3TN1P	EH12-3403-3AL	AN12NT	1723-4 (2)	1783-2 (2)	3921-1	2753 (70)
FH100-4166-2	(2P) FC39-3664NB (BL) CB2-4007NB	HS08X35DP	5089-2TN1P	FH11-3172-2AL	OS46NT	1724-2 (1)	1783-3 (1)	3921-1	2753 (70)
FH200-4166-3	(2P) FC39-3664NB (BL) CB2-4007NB	HS08X35DP	5089-3TN1P	FH21-3172-3AL	OS46NT	1724-2 (1)	1783-3 (1)	3921-1	2753 (70)
FH300-4167-2	(2P) FG13-3655NB (BL) FG11-3654NB	HS08X35DP	5090-2TN1P	FH30-3276-2AL	OS52NT	1724-4 (2)	1783-3 (2)	3921-1	2753 (70)
FH400-4167-3	(2P) FG13-3655NB (BL) FG11-3654NB	HS08X35DP	5090-3TN1P	FH46-3276-3AL	OS52NT	1724-4 (2)	1783-3 (2)	3921-1	2753 (70)
GH200-4168-2	(2P) GL16-4208NB (BL) GL17-4209NB	HS10X40DP	3447-2TN1B	GH29-3433-2AL	OS63NT	1725-3 (2)	1783-4 (2)	3921-1	2753 (70)
GH300-4168-3	(2P) GL16-4208NB (BL) GL17-4209NB	HS10X40DP	3447-3TN1B	GH34-3433-3AL	OS63NT	1725-3 (2)	1783-4 (2)	3921-1	2753 (70)
GH400-4168-4	(2P) GL16-4208NB (BL) GL17-4209NB	HS10X40DP	3447-4TN1B	GH36-3433-4AL	OS63NT	1725-3 (2)	1783-4 (2)	3921-1	2753 (70)
KH200-4169-3	(2P) GK62-3644GM (BL) GK61-3643GM	HS12X50DP	4048-3TN1B	KH20-3072-3AL	OS69NT	N/A	1783-5 (2)	3921-2	2748 (70)
KH300-4169-4	(2P) GK62-3644GM (BL) GK61-3643GM	HS12X50DP	4048-4TN1B	KH30-3072-4AL	OS69NT	N/A	1783-5 (2)	3921-2	2748 (70)
KH400-4169-5	(2P) GK62-3644GM (BL) GK61-3643GM	HS12X50DP	4048-5TN1B	KH40-3072-5AL	OS69NT	N/A	1783-5 (2)	3921-2	2748 (70)
JH200-4170-3	(2P) JK7-4193GM (BL) JK8-4194GM	HS16X70DP	4049-3TN1B	JH20-3330-3AL	OS74NT	N/A	1783-6 (2)	3921-2	2748 (70)
JH300-4170-4	(2P) JK7-4193GM (BL) JK8-4194GM	HS16X70DP	4049-4TN1B	JH30-3330-4AL	OS74NT	N/A	1783-6 (2)	3921-2	2748 (70)
JH400-4170-5	(2P) JK7-4193GM (BL) JK8-4194GM	HS16X70DP	4049-5TN1B	JH40-3330-5AL	OS74NT	N/A	1783-6 (2)	3921-2	2748 (70)
PH200-4171-4	(2P) PK7-4195GM (BL) PK8-4196GM	HS16X65DP	4050-4TN1B	PH20-3074-4AL	OS81NT	N/A	1783-6 (2)	3921-3	3054 (50)
PH300-4171-5	(2P) PK7-4195GM (BL) PK8-4196GM	HS16X65DP	4050-5TN1B	PH30-3074-5AL	OS81NT	N/A	1783-6 (2)	3921-3	3054 (50)
PH400-4171-6	(2P) PK7-4195GM (BL) PK8-4196GM	HS16X65DP	4050-6TN1B	PH40-3074-6AL	OS81NT	N/A	1783-6 (2)	3921-3	3054 (50)

## Jacket Water Connection

All Bowman Header Tank heat exchangers are supplied with either hose adaptors or blank counter flange plates on the engine water inlet and outlet side, for connecting the engine jacket water to the heat exchanger.

### Hose adaptors

Hose adaptors are supplied as standard on the following header tank models:

**EH 100 & 200** – these units are supplied with two composite hose adaptors for the water inlet and outlet and come complete with Nitrile 'O' ring seals and M8 socket screws.

**FH 100 & 200** – these units are supplied with one composite hose adaptor for the water inlet (the water outlet being cast into the body of the heat exchanger) together with Nitrile 'O' ring seals and M10 socket screws.

**FH 300 & 400** – these units are supplied with two composite hose adaptors for the water inlet and outlet and come complete with Nitrile 'O' ring seals and M10 socket screws.

**GH 200, 300 & 400** – these units are supplied with two cast aluminium hose adaptors for the water inlet and outlet and come complete with Nitrile 'O' ring seals and M12 socket screws

## Blank counter flange plates

Bowman KH, JH and PH Header Tank heat exchangers are provided with two blank counter flange plates for the water inlet and outlet, which must be modified by the customer to enable the appropriate connections to be made, to connect the engine's jacket water circuit to the heat exchanger.

NOTE: for customers wishing to use blank counter flange plates instead of hose adaptors on their EH, FH or GH units, these are available to special order only and at additional cost. Please see the 'Replacement Parts' section of this brochure for ordering details.



Blank counter flange plate



FH 200 with water inlet hose adaptor

## Servicing the unit

By simply unscrewing the end cover retaining screws, the tube stack can be removed from its outer 'shell' for routine cleaning and maintenance. On reassembly, it is always recommended that the "O" rings are replaced to ensure a reliable, watertight seal.

EH & FH composite hose adaptors



GH aluminium hose adaptors

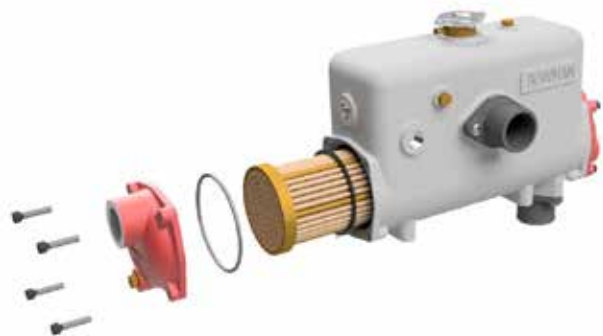

All material contained in this brochure is the intellectual property of EJ Bowman (Birmingham) Ltd. It is protected under copyright and may not be reproduced without prior written consent of the company.



## Titanium Tube Stacks

Titanium is the ultimate 'fit and forget' solution for any application where super aggressive water conditions exist, including salt water, or contaminated / mineral rich fresh water. It resists chemical attack indefinitely and also eliminates the possibility of 'galvanic reaction' between dissimilar materials – often the cause of premature failure in certain operating conditions.

Bowman can now offer Titanium tube stacks as an option for many of our Header Tank heat exchangers, providing a highly durable, long-life solution for the most demanding applications.

All Titanium tube stacks benefit from a full 10-year guarantee and, as a further advantage, they also offer the ability to operate at higher flow rates compared to standard cupro-nickel, without the risk of tube erosion.



**GUARANTEED**  
**10**  
**YEARS**

Full 10-year guarantee on all titanium material in contact with cooling water.

## Installation and Maintenance

- 1: Bowman Header Tank heat exchangers must always be mounted above the engine's cylinder head level.
- 2: The engine water circuit should be arranged so that it is self-venting on initial filling.
- 3: A by-pass type thermostat should be used and arranged so that only the heat exchanger is by-passed when the engine is cold.
- 4: Ensure all other cooling components are positioned in the circuit so they receive the full flow of coolant from the engine's water pump. These units include water jacketed Exhaust Manifolds (if fitted), Oil Coolers, Charge Air Coolers and Exhaust Gas heat exchangers.
- 5: Automotive type thermostats, which simply interrupt the cooling water flow when the engine is cold, are not recommended for use with Bowman header tank heat exchangers.
- 6: When operated unattended, it is recommended that an automatic engine shutdown system is always installed.
- 7: Bowman recommend using an ethylene glycol solution on the engine circuit in the concentration advised by the engine manufacturer for the operating conditions. Should you intend to use an alternative coolant, please contact our technical sales team.

## Total Engine Cooling Solutions

For nearly 100 years, Bowman has provided efficient, reliable cooling solutions for normally aspirated and forced induction engines. During that time the company has amassed a wealth of expertise and can provide a complete cooling solution for both marine and land-based stationary engines, including:

### Charge Air Coolers

Improved combustion efficiency and reduced fuel consumption are just some of the benefits provided by Bowman charge air coolers.



### Exhaust Gas Heat Exchangers

Recovers valuable 'waste heat' from the engine's exhaust stream for use as a valuable 'free' energy resource



### Engine & Gearbox Oil Coolers

A range of compact units suitable for engine or transmission oil cooling



### Fuel Coolers

Bowman inline plate fuel coolers are compact, easy to install and suitable for use with all fuel types – including ethanol-rich fuels



# A world of applications

Bowman Header Tank heat exchangers can be found cooling engines in some of the most extreme conditions in the world. From the searing heat of an Australian summer, to the chilling depths of an Arctic winter, plus just about every other operating condition in between. Here are just a few examples.

## Irrigation Systems



In Australia - Bowman FH300 Header Tank heat exchangers are being used to cool Iveco 6.7L irrigation pump sets at a grape vineyard to ensure the pump's engines run at their optimum efficiency, even in the challenging climate of a New South Wales summer!

## Marine Engineering



In Portugal, Bowman Header Tank heat exchangers have been used to convert two John Deere engines for marine operation. The installation, on the catamaran 'Independencia', reduced temperatures in the engine room from over 50° C, to just 25° C.

## Automotive Engine Testing



Within many of the world's engine testing facilities, you'll find Bowman Header Tank heat exchangers precisely controlling engine coolant temperatures in both extreme hot and cold operating conditions.

## Fire Protection Systems



At Durban International Airport, South Africa, Bowman Header Tank heat exchangers are at the heart of a 'mission critical' fire protection system which, in the event of an emergency, either with aircraft take-off and landing, or at the airport's bulk fuel stores, dispenses thousands of gallons of foam to support emergency response teams.



Bowman is now established as the 'leading brand' for Header Tank heat exchangers. With tens of thousands of units operating reliably and efficiently throughout the world, you can have complete confidence when you specify Bowman Header Tank heat exchangers.

### **EJ Bowman (Birmingham) Ltd**

Chester Street, Birmingham B6 4AP, UK

Tel: +44 (0) 121 359 5401

Fax: +44 (0) 121 359 7495

Email: [sales@ej-bowman.com](mailto:sales@ej-bowman.com)

[www.ej-bowman.com](http://www.ej-bowman.com)

**BOWMAN**<sup>®</sup>  
100 YEARS OF HEAT TRANSFER TECHNOLOGY

EJ Bowman (Birmingham) Ltd, reserve the right to change specifications without prior notice.



FM38224

D22