

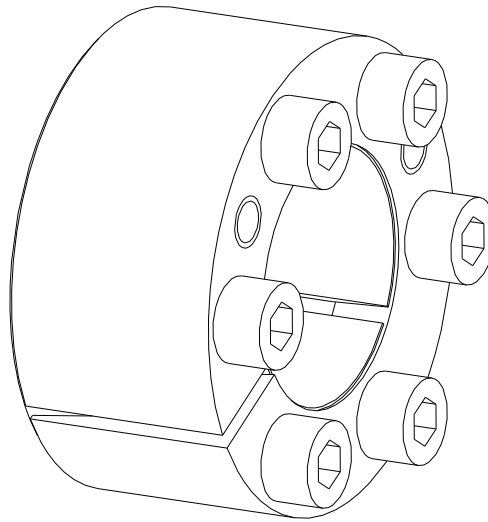

CLAMPEX® KTR 105



The **CLAMPEX® clamping set** is a frictionally engaged, detachable shaft-hub-connection for cylindrical shafts and bores without feather key.

Table of contents

1	Technical data	2
2	Advice	3
2.1	General advice	3
2.2	Safety and advice symbols	3
2.3	General hazard warnings	3
2.4	Intended use	4
3	Storage, transport and packaging	4
3.1	Storage	4
3.2	Transport and packaging	4
4	Assembly	4
4.1	Components of clamping set CLAMPEX® KTR 105	4
4.2	Assembly of the clamping set	5
4.3	Disassembly of clamping set	6
5	Disposal	7
6	Spares inventory, customer service addresses	7
7	Advice regarding the use in  hazardous locations according to EU directive 2014/34/EU	7

1 Technical data

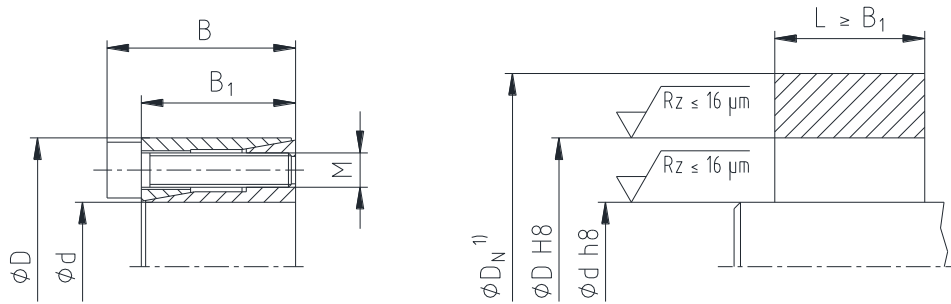

Illustration 1: Dimensions of CLAMPEX® KTR 105

- 1) Dimension D_N : For calculation of hub see catalogue "Drive Technology"
- 2) These are the maximum screw tightening torques. They can be reduced by a maximum of 40 % of the figures specified, with T , F_{ax} , P_W and P_N declining proportionally.

Table 1: Technical data

Dimensions [mm]			Clamping screws DIN EN ISO 4762 - 12.9 $\mu_{total} = 0.14$				Transmittable torque or axial force		Surface pressure between clamping set [N/mm ²]		Weight [kg]
d x D	B	B ₁	M	Length	Z Quan- tity	T _A ²⁾ [Nm]	T [Nm]	F _{ax} [kN]	Shaft P _W	Hub P _N	
5 x 16	13.5	11	M2.5	10	3	1.2	5	2	177	55	0.01
6 x 16	13.5	11	M2.5	10	3	1.2	6	2	147	55	0.01
6.35 x 16	13.5	11	M2.5	10	3	1.2	6	2	132	52	0.01
7 x 17	13.5	11	M2.5	10	3	1.2	8	2	144	59	0.01
8 x 18	13.5	11	M2.5	10	3	1.2	10	3	138	61	0.02
9 x 20	15.5	13	M2.5	12	4	1.2	15	3	140	63	0.02
9.53 x 20	15.5	13	M2.5	12	4	1.2	15	3	125	60	0.02
10 x 20	15.5	13	M2.5	12	4	1.2	15	3	114	57	0.02
11 x 22	15.5	13	M2.5	12	4	1.2	18	3	113	56	0.02
12 x 22	15.5	13	M2.5	12	4	1.2	20	3	105	57	0.02
14 x 26	20	17	M3	16	4	2.1	35	5	105	57	0.04
15 x 28	20	17	M3	16	4	2.1	40	5	94	51	0.04
16 x 32	21	17	M4	16	4	4.9	70	9	132	66	0.07
17 x 35	25	21	M4	20	4	4.9	75	9	125	61	0.09
18 x 35	25	21	M4	20	4	4.9	80	9	119	61	0.09
19 x 35	25	21	M4	20	4	4.9	85	9	114	62	0.08
20 x 38	26	21	M5	20	4	9.7	150	15	153	81	0.1
22 x 40	26	21	M5	20	4	9.7	160	15	135	74	0.1
24 x 47	32	26	M6	25	4	16.5	250	21	154	78	0.2
25 x 47	32	26	M6	25	4	16.5	260	21	147	78	0.2
28 x 50	32	26	M6	25	6	16.5	440	31	198	111	0.2
30 x 55	32	26	M6	25	6	16.5	470	31	185	101	0.3
32 x 55	32	26	M6	25	6	16.5	500	31	173	100	0.25
35 x 60	37	31	M6	30	8	16.5	730	42	166	97	0.35
38 x 65	37	31	M6	30	8	16.5	800	42	155	90	0.4
40 x 65	37	31	M6	30	8	16.5	840	42	147	90	0.4
42 x 75	44	36	M8	35	6	40	911	43	125	70	0.7
45 x 75	44	36	M8	35	8	40	1300	58	155	93	0.6
48 x 80	44	36	M8	35	8	40	1824	76	191	115	0.7
50 x 80	44	36	M8	35	8	40	1900	76	183	115	0.7

1 Technical data

Tolerances, surfaces

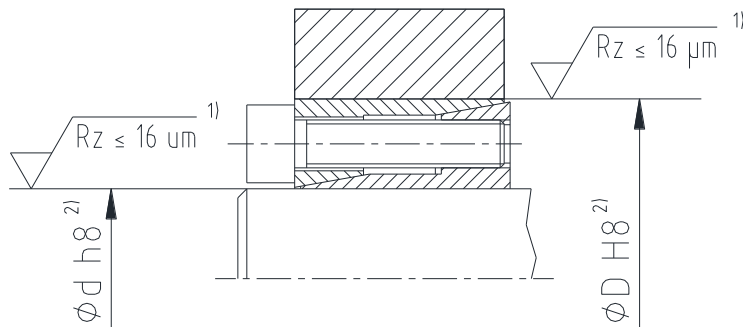

Illustration 3: Tolerances and surfaces (example: CLAMPEX® KTR 105)

- 1) One proper turning process is sufficient ($Rz \leq 16 \mu\text{m}$).
- 2) Highest permissible tolerance of the hub or shaft.

2 Advice

2.1 General advice

Please read through these operating/assembly instructions carefully before you mount the clamping set. Please pay special attention to the safety instructions! The operating/assembly instructions are part of your product. Please store them carefully and close to the clamping set. The copyright for these operating/assembly instructions remains with KTR.

2.2 Safety and advice symbols



Warning of potentially explosive atmospheres

This symbol indicates notes which may contribute to preventing bodily injuries or serious bodily injuries that may result in death caused by explosion.



Warning of personal injury

This symbol indicates notes which may contribute to preventing bodily injuries or serious bodily injuries that may result in death.



Warning of product damages

This symbol indicates notes which may contribute to preventing material or machine damage.



General advice

This symbol indicates notes which may contribute to preventing adverse results or conditions.

2.3 General hazard warnings



With assembly and disassembly of the clamping set it has to be made sure that the entire drive train is secured against accidental switch-on. You may be seriously hurt by rotating parts. Please make absolutely sure to read through and observe the following safety indications.

- All operations on and with the clamping set have to be performed taking into account "safety first".
- Please make sure to switch off the power pack before you perform your work on the clamping set.
- Secure the power pack against accidental switch-on, e. g. by providing warning signs at the place of switch-on or removing the fuse for current supply.
- Do not reach into the operation area of the machine as long as it is in operation.
- Please secure the rotating drive components against accidental contact. Please provide for the necessary protection devices and covers.

Please observe protection note ISO 16016.	Drawn: 2016.09.09 Shg/Jh	Replacing: KTR-N dated 2016.05.10
	Verified: 2016.09.09 Shg	Replaced by:

**2 Advice****2.4 Intended use**

You may only assemble and disassemble the clamping set if you

- have carefully read through the operating/assembly instructions and understood them
- had technical training
- are authorized by your company

The clamping set may only be used in accordance with the technical data (see chapter 1). Unauthorized modifications on the clamping set are not admissible. We will not assume liability for any damage that may arise. In the interest of further development we reserve the right for technical modifications.

The clamping set described in here corresponds to the technical status at the time of printing of these operating/assembly instructions.

3 Storage, transport and packaging**3.1 Storage**

The clamping sets are supplied in preserved condition and can be stored at a dry and roofed place for 6 - 9 months.



**Humid storage rooms are not suitable.
Please make sure that condensation is not generated.**

3.2 Transport and packaging

In order to avoid any injuries and any kind of damage please always make use of proper transport and lifting equipment.

The clamping sets are packed differently each depending on size, quantity and kind of transport. Unless otherwise contractually agreed, packaging will follow the in-house packaging specifications of KTR.

4 Assembly

Generally the clamping set is supplied in mounted condition. Before assembly the clamping set has to be inspected for completeness.

4.1 Components of clamping set CLAMPEX® KTR 105

Component	Quantity	Description
1	1	Outer ring (slit)
2	1	Inner ring (slit)
3	see catalogue	Cap screw DIN EN ISO 4762



4 Assembly
4.1 Components of clamping set CLAMPEX® KTR 105

Illustration 2: CLAMPEX® KTR 105



With assembly none of the pull-off threads of the internal ring may be congruent with the slot of the external ring.

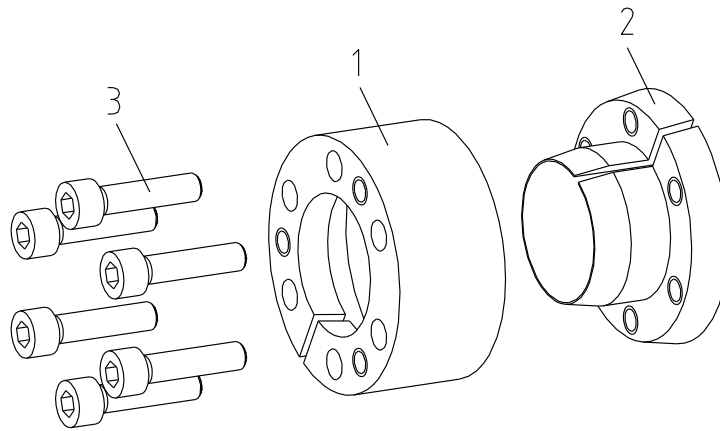

Dirty or used clamping sets have to be disassembled and cleaned before assembly. Afterwards apply thin fluid oil lightly (e. g. Ballistol Universal oil or Klüber Quietsch-Ex).

4.2 Assembly of the clamping set

- Inspect the fit of shaft and hub for the tolerance specified (see illustration 1).
- Clean the surfaces of the clamping set marked in illustration 3 as well as of shaft and hub and afterwards apply thin fluid oil lightly (e. g. Ballistol Universal oil or Klüber Quietsch-Ex).

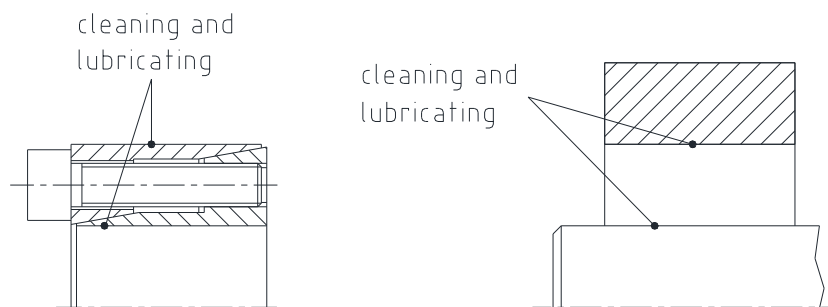

Illustration 3: Cleaning the contact surfaces



Oils and greases with molybdenum disulphide or high-pressure additives, additives of Teflon and silicone as well as internal lubricants reducing the coefficient of friction significantly must not be used. When mounting the tapers of the clamping set free from oil the tabular and calculated parameters deviate.

- Release the clamping screws slightly. To facilitate the assembly fasten the internal and external ring by two clamping screws each via the pull-off threads (see illustration 4). Insert the clamping set KTR 105 between shaft and hub.

**4 Assembly****4.2 Assembly of the clamping set**

Illustration 4: Fastening the clamping set

- Remove the clamping screws used for fastening and screw them into the thread of the external ring.
- Lightly tighten the clamping screws manually and align the clamping set with hub part.
- Tighten the clamping screws evenly crosswise step by step and with several revolutions to the tightening torque specified in table 1 or 2. Repeat this process until all clamping screws have reached the tightening torque.

•

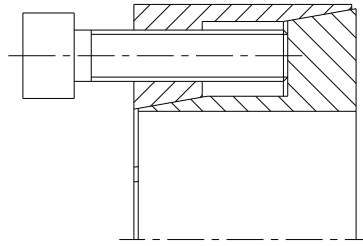

During assembly the hub is displaced axially towards the shaft.

4.3 Disassembly of clamping set

Driving components released or falling down may cause injury to persons or damage on the machine.

Secure the driving components before disassembly.

- Untighten and unscrew all clamping screws evenly and one after another.
- Screw the clamping screws into the pull-off threads of the internal ring (component 2) (see illustration 5).
- Tighten the clamping screws evenly crosswise by 1/4 revolution. Increase the pull-off torque stepwise until the external ring (component 1) and internal ring (component 2) are separated.
- Take out the clamping set released between shaft and hub.

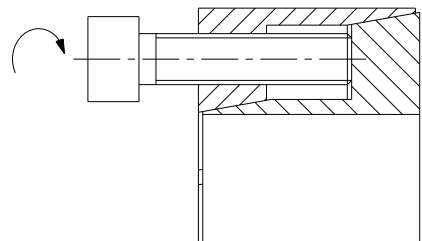

Illustration 5: Releasing the clamping set KTR 105



If these hints are not observed or operating conditions are not taken into account with the selection of the clamping set, the operation of the clamping set may be affected.

**5 Disposal**

In respect of environmental protection we would ask you to dispose of the packaging or products on termination of their service life in accordance with the legal regulations and standards that apply, respectively.
All clamping sets consist of metal. Any metal components have to be cleaned and disposed of by scrap metal.

6 Spares inventory, customer service addresses

A basic requirement to ensure the operational readiness of the drive components is a stock of some clamping sets on site.

Contact addresses of the KTR partners for spare parts and orders can be obtained from the KTR homepage at www.ktr.com.



KTR does not assume any liability or warranty for the use of spare parts and accessories which are not provided by KTR and for the damages which may incur as a result.

7 Advice regarding the use in  hazardous locations according to EU directive 2014/34/EU

If used in hazardous locations the type and size of clamping set (for category 3 only) has to be selected such that the difference between the peak torque of the machine including all operating parameters and the rated torque of the clamping hub at least corresponds to a safety factor of $s = 2.0$.

CLAMPEX® clamping sets are not part of directive 2014/34/EU, since

- this product is a torsionally rigid, backlash-free, frictionally engaged connection with one or more taper clamping ring(s) by means of several screws.
(Clamping screws have to be secured, e. g. by means of a medium strength adhesive.)
- due to the design of clamping sets a fracture/failure is not likely (frictional heat is only caused by improper assembly/tightening torques, i. e. not with intended use).

Any questions? Please contact us.