

CLAMPEX® KTR 130

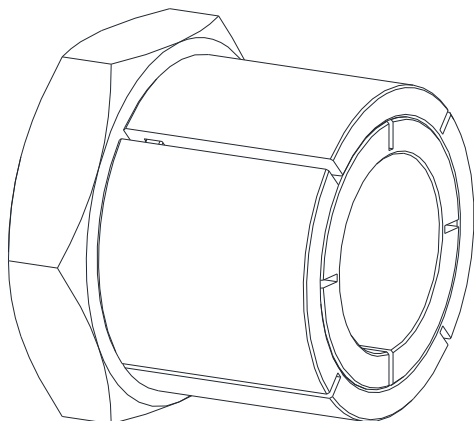

CLAMPEX® KTR 131

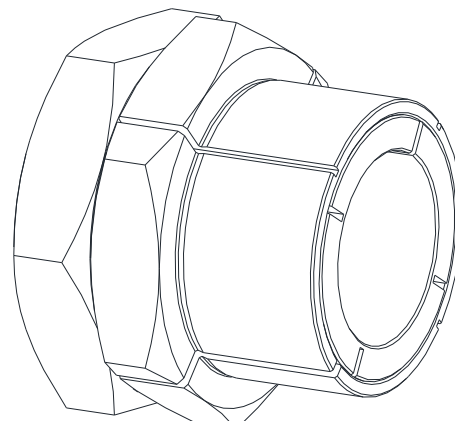

The **CLAMPEX® clamping set** is a frictionally engaged, detachable shaft-hub-connection for cylindrical shafts and bores without feather key.

Table of contents

1	Technical data	2
2	Advice	4
2.1	General advice	4
2.2	Safety and advice symbols	4
2.3	General hazard warnings	4
2.4	Intended use	4
3	Storage, transport and packaging	5
3.1	Storage	5
3.2	Transport and packaging	5
4	Assembly	5
4.1	Components of CLAMPEX® KTR 130 / KTR 131	5
4.2	Assembly of the clamping set	6
4.3	Disassembly of clamping set	6
5	Disposal	7
6	Spares inventory, customer service addresses	7
7	Advice regarding the use in  hazardous locations according to EU directive 2014/34/EU	7



1 Technical data

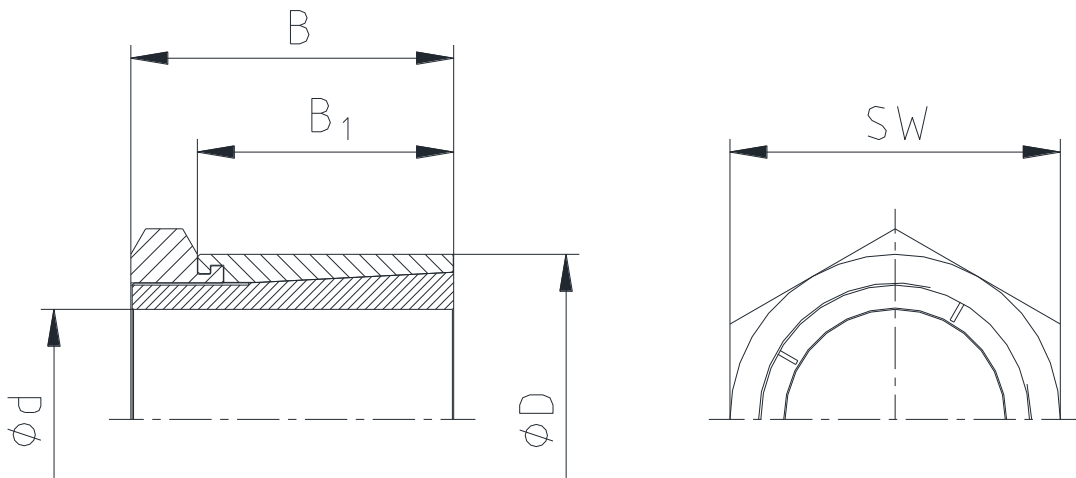

Illustration 1: Dimensions of CLAMPEX® KTR 130

Table 1: CLAMPEX® KTR 130

Dimensions [mm]			Hexagon nut		Transmittable Torque or axial force		Surface pressure between clamping set [N/mm ²]		Weight [~kg]
d x D	B	B ₁	Width across flats SW	T _A [Nm]	T [Nm]	F _{ax} [kN]	Shaft P _w	Hub P _N	
5 x 14	19	15	14	10	10.1	4.0	264	96	0.02
6 x 14	19	15	14	10	12.1	4.0	220	96	0.02
8 x 16	22	17	17	17	23.4	5.8	179	91	0.02
9 x 20	24	19	22	35	43.2	9.7	248	112	0.04
10 x 20	24	19	22	35	48.6	9.7	223	112	0.05
12 x 22	24	19	22	44	65.3	10.9	206	117	0.05
14 x 26	28	22	27	65	93.0	13.3	178	99	0.08
15 x 26	28	22	27	65	99.0	13.3	166	99	0.08
16 x 26	28	22	27	65	106	13.3	156	99	0.07
18 x 35	36	27	36	161	223	24.8	224	125	0.2
19 x 35	36	27	36	161	235	24.8	212	125	0.2
20 x 35	36	27	36	161	248	24.8	201	125	0.2
22 x 42	41	30	46	250	349	31.8	197	110	0.3
24 x 42	41	30	46	250	381	31.8	180	110	0.3
25 x 42	41	30	46	250	397	31.8	173	110	0.3
30 x 47	44	33	50	355	605	40.4	162	110	0.4
32 x 55	51	38	55	490	764	47.8	166	102	0.6
35 x 55	51	38	55	490	836	47.8	151	102	0.6
40 x 62	58	43	65	800	1329	66.5	152	98	0.8
45 x 65	63	48	65	900	1605	71.0	142	98	0.9
48 x 75	73	58	75	1290	2227	92.0	121	77	1.5
50 x 75	73	58	75	1290	2320	92.0	116	77	1.4



1 Technical data

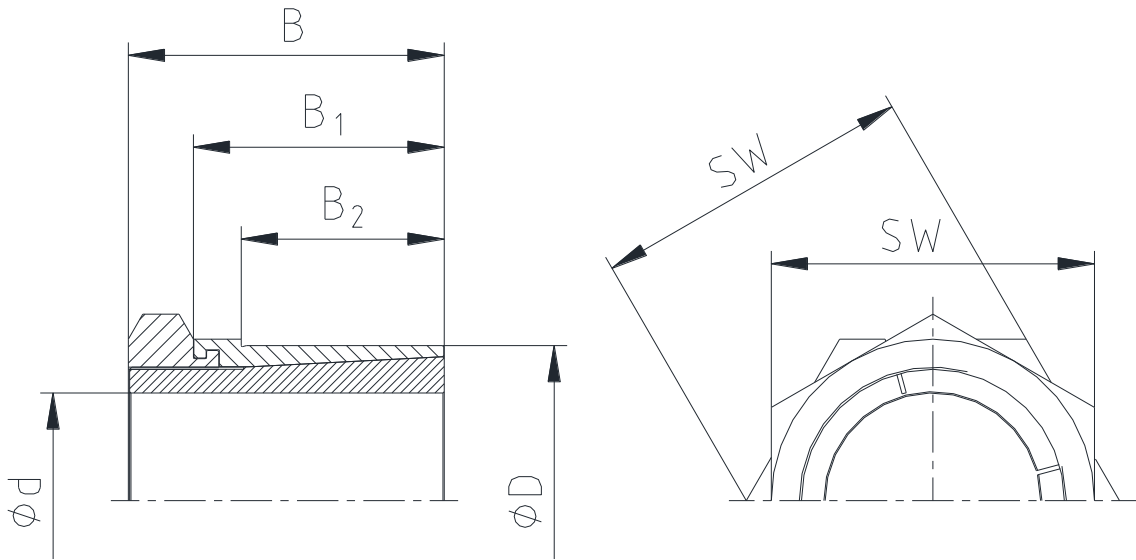

Illustration 2: Dimensions of CLAMPEX® KTR 131

Table 2: CLAMPEX® KTR 131

Dimensions [mm]				Hexagon nut		Transmittable Torque or axial force		Surface pressure between clamping set [N/mm ²]		Weight [~kg]
d x D	B	B ₁	B ₂	Width across flats SW	T _A [Nm]	T [Nm]	F _{ax} [kN]	Shaft P _W	Hub P _N	
5 x 12	19	15	9	14	10	10.1	4.0	264	119	0.02
6 x 12	19	15	9	14	10	12.1	4.0	220	119	0.02
8 x 14	22	17	11	17	17	23.4	5.8	179	121	0.02
10 x 18	24	19	12	22	35	48.6	9.7	221	127	0.04
12 x 20	24	19	12	22	44	65.3	10.9	206	128	0.04
14 x 24	28	22	15	27	65	93.0	13.3	178	107	0.08
15 x 24	28	22	15	27	65	99.0	13.3	166	107	0.07
16 x 24	28	22	15	27	65	106	13.3	156	107	0.07
18 x 30	36	27	17	36	161	223	24.8	224	145	0.2
19 x 30	36	27	17	36	161	235	24.8	212	145	0.2
20 x 30	36	27	17	36	161	248	24.8	201	145	0.2
22 x 38	41	30	20	46	250	349	31.8	197	122	0.35
24 x 38	41	30	20	46	250	381	31.8	180	122	0.3
25 x 38	41	30	20	46	250	397	31.8	173	122	0.3
30 x 42	44	33	23	50	355	605	40.4	162	123	0.35
32 x 50	51	38	28	55	490	764	47.8	166	112	0.55
35 x 50	51	38	28	55	490	836	47.8	151	112	0.5

Tolerances, surfaces

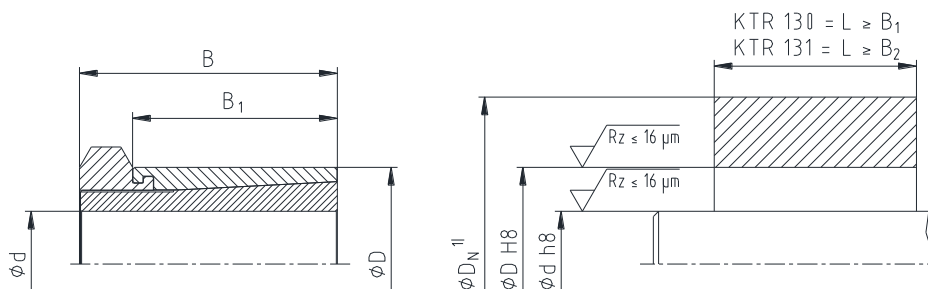

Illustration 3: Tolerances and surfaces (example: CLAMPEX® KTR 225)

- 1) One proper turning process is sufficient ($R_z \leq 16 \mu\text{m}$).
- 2) Highest permissible tolerance of hub or shaft.

Please observe protection note ISO 16016.	Drawn:	2016-12-22 Shg/Jh	Replacing:	KTR-N dated 2014-09-18
	Verified:	2016-12-22 Shg	Replaced by:	

2 Advice

2.1 General advice

Please read through these operating/assembly instructions carefully before you mount the clamping set. Please pay special attention to the safety instructions! The operating/assembly instructions are part of your product. Please store them carefully and close to the clamping set. The copyright for these operating/assembly instructions remains with KTR.

2.2 Safety and advice symbols



Warning of potentially explosive atmospheres

This symbol indicates notes which may contribute to preventing bodily injuries or serious bodily injuries that may result in death caused by explosion.



Warning of personal injury

This symbol indicates notes which may contribute to preventing bodily injuries or serious bodily injuries that may result in death.



Warning of product damages

This symbol indicates notes which may contribute to preventing material or machine damage.



General advice

This symbol indicates notes which may contribute to preventing adverse results or conditions.

2.3 General hazard warnings



With assembly and disassembly of the clamping set it has to be made sure that the entire drive train is secured against accidental switch-on. You may be seriously hurt by rotating parts. Please make absolutely sure to read through and observe the following safety indications.

- All operations on and with the clamping set have to be performed taking into account "safety first".
- Please make sure to switch off the power pack before you perform your work on the clamping set.
- Secure the power pack against accidental switch-on, e. g. by providing warning signs at the place of switch-on or removing the fuse for current supply.
- Do not reach into the operation area of the machine as long as it is in operation.
- Please secure the rotating drive components against accidental contact. Please provide for the necessary protection devices and covers.

2.4 Intended use

You may only assemble and disassemble the clamping set if you

- have carefully read through the operating/assembly instructions and understood them
- had technical training
- are authorized by your company

The clamping set may only be used in accordance with the technical data (see table 1 and 2). Unauthorized modifications on the clamping set are not admissible. We will not assume liability for any damage that may arise. In the interest of further development we reserve the right for technical modifications.

The clamping set described in here corresponds to the technical status at the time of printing of these operating/assembly instructions.

Please observe protection note ISO 16016.	Drawn: 2016-12-22 Shg/Jh	Replacing: KTR-N dated 2014-09-18
	Verified: 2016-12-22 Shg	Replaced by:

3 Storage, transport and packaging

3.1 Storage

The clamping sets are supplied in preserved condition and can be stored at a dry and covered place for 6 - 9 months.



Humid storage rooms are not suitable.
Please make sure that condensation is not generated.

3.2 Transport and packaging



In order to avoid any injuries and any kind of damage please always make use of proper transport and lifting equipment.

The clamping sets are packed differently each depending on size, quantity and kind of transport. Unless otherwise contractually agreed, packaging will follow the in-house packaging specifications of KTR.

4 Assembly

Generally the clamping set is supplied in mounted condition. Before assembly the clamping set has to be inspected for completeness.

4.1 Components of CLAMPEX® KTR 130 / KTR 131

Component	Quantity	Description
1	1	Hexagon nut
2	1	Outer ring (slit)
3	1	Outer ring with counter hexagon bolt (slot)
4	1	Inner ring (slit)

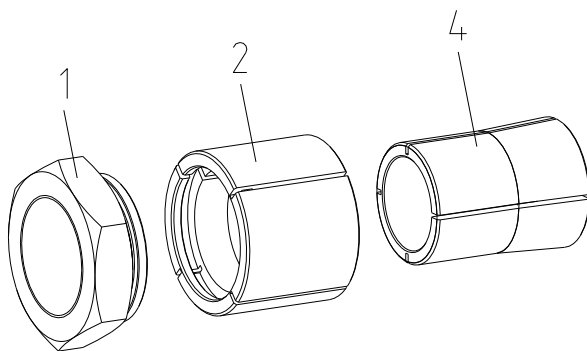

Illustration 3: CLAMPEX® KTR 130

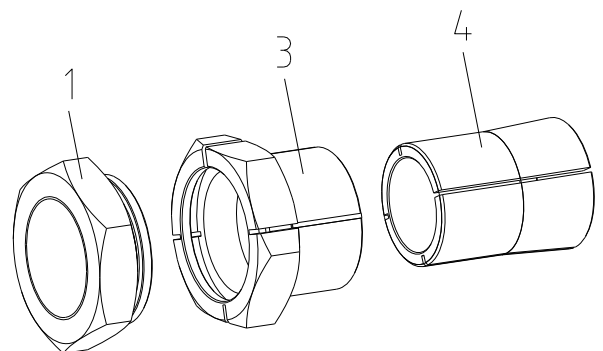

Illustration 4: CLAMPEX® KTR 131



Dirty or used clamping sets have to be disassembled and cleaned before assembly. Afterwards apply thin fluid oil lightly (e. g. Ballistol Universal oil or Klüber Quietsch-Ex).

**4 Assembly****4.2 Assembly of the clamping set**

- Please inspect shaft and hub fit for the tolerance specified (h8/H8).
- Clean the hub bore and shaft and afterwards apply a thin-fluid oil (e. g. Ballistol Universal oil or Klüber Quietsch-Ex).



Oils and greases with molybdenum disulphide or high-pressure additives, additives of Teflon and silicone as well as internal lubricants reducing the coefficient of friction significantly must not be used. When mounting the tapers of the clamping set free from oil the tabular and calculated parameters deviate.

- Release the hexagon nut (component 1) and insert the clamping set KTR 130/KTR 131 between shaft and hub.
- Lightly tighten the hexagon nut and align clamping set and hub components.
- Tighten the hexagon nut at the tightening torque T_A specified in table 1.



During assembly the hub is displaced axially towards the shaft.



Clamping set KTR 131 with counter hexagon bolt for clamping on lightly twistable shafts.

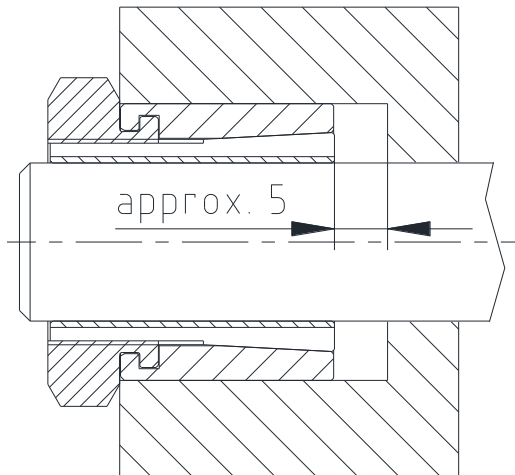

Illustration 5: Clamping set KTR 130 fully assembled

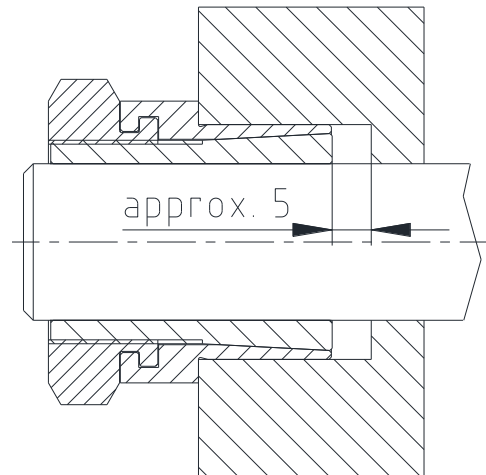

Illustration 6: Clamping set KTR 131 fully assembled

4.3 Disassembly of clamping set

Driving components released or falling down may cause injury to persons or damage on the machine.

Secure the driving components before disassembly.

- Release the hexagon nut (component 1).
- Turn the hexagon nut left until the clamping set KTR 130/KTR 131 can be shifted on the shaft.
- Take out the clamping set released between shaft and hub.

**4 Assembly****4.3 Disassembly of clamping set**

If these hints are not observed or operating conditions are not taken into account with the selection of the clamping set, the operation of the clamping set may be affected.

5 Disposal

In respect of environmental protection we would ask you to dispose of the packaging or products on termination of their service life in accordance with the legal regulations and standards that apply, respectively.

All clamping sets consist of metal. Any metal components have to be cleaned and disposed of by scrap metal.

6 Spares inventory, customer service addresses

A basic requirement to ensure the readiness for use of the drive components is a stock of some clamping sets on site.

Contact addresses of the KTR partners for spare parts and orders can be obtained from the KTR homepage at www.ktr.com.



KTR does not assume any liability or warranty for the use of spare parts and accessories which are not provided by KTR and for the damages which may incur as a result.

7 Advice regarding the use in  hazardous locations according to EU directive 2014/34/EU

If used in hazardous locations the type and size of clamping set (for category 3 only) has to be selected such that the difference between the peak torque of the machine including all operating parameters and the rated torque of the clamping hub at least corresponds to a safety factor of $s = 2.0$.

CLAMPEX® clamping sets are not part of EU directive 2014/34/EU, since

- this product is a torsionally rigid, backlash-free, frictionally engaged connection with one or more taper clamping ring(s) by means of several screws.
(Clamping screws have to be secured, e. g. by means of a medium strength adhesive.)
- due to the design of clamping sets a fracture/failure is not likely (frictional heat is only caused by improper assembly/tightening torques, i. e. not with intended use).

Any questions? Please contact us.