

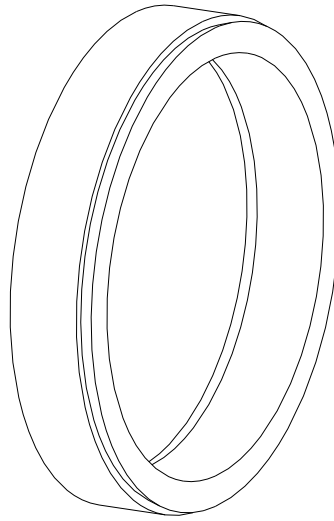

## CLAMPEX® KTR 150



The **CLAMPEX® clamping set** is a frictionally engaged, detachable shaft-hub-connection for cylindrical shafts and bores without feather key.

### Table of contents

<b>1</b>	<b>Technical data</b>	<b>2</b>
<b>2</b>	<b>Advice</b>	<b>4</b>
2.1	General advice	4
2.2	Safety and advice symbols	4
2.3	General hazard warnings	5
2.4	Intended use	5
<b>3</b>	<b>Storage, transport and packaging</b>	<b>5</b>
3.1	Storage	5
3.2	Transport and packaging	5
<b>4</b>	<b>Assembly</b>	<b>6</b>
4.1	Components of clamping set	6
4.2	Assembly of clamping set	7
4.3	Disassembly of clamping set	9
<b>5</b>	<b>Disposal</b>	<b>9</b>
<b>6</b>	<b>Spares inventory, customer service addresses</b>	<b>9</b>
<b>7</b>	<b>Advice regarding the use in  potentially explosive atmospheres according to EU directive 2014/34/EU</b>	<b>9</b>

**1 Technical data**

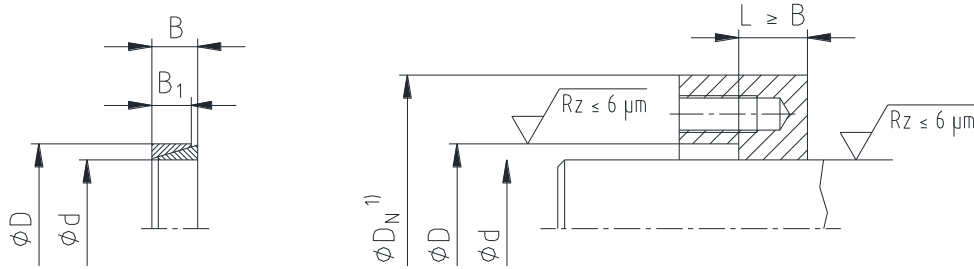

1) Dimension D<sub>N</sub>: For calculation of hub see catalogue "Drive Technology"

**Tolerances for d and D**  
d ≤ 38 mm = d h6/D H7  
d > 38 mm = d h8/D H8

Illustration 1: CLAMPEX® KTR 150

**Table 1: Technical data**

Dimensions [mm]			Distance dimension A [mm]				Clamping screws clamping force required $\mu_{total} = 0.14$			Transmittable torque or axial force		Surface pressure between clamping set [N/mm <sup>2</sup> ]		Weight ~ kg
d x D <sup>1)</sup>	B	B <sub>1</sub>	Clamping elements				P <sub>O</sub> [kN]	P <sub>S</sub> [kN]	P <sub>A</sub> = P <sub>O</sub> + P <sub>S</sub> [kN]	T [Nm]	F <sub>ax</sub> [kN]	Shaft P <sub>W</sub>	Hub P <sub>N</sub>	
			1	2	3	4								
6 x 9	4.5	3.7	3	3	3	4	**	3	3	2	0.6	80	53	0.0015
7 x 10	4.5	3.7	3	3	3	4	**	5	5	4	1	117	82	0.0014
8 x 11	4.5	3.7	3	3	3	4	**	6	6	5	1	112	81	0.0015
9 x 12	4.5	3.7	3	3	3	4	8	8	16	8	1	142	106	0.0017
10 x 13	4.5	3.7	3	3	3	4	7	9	16	10	2	143	110	0.0018
12 x 15	4.5	3.7	3	3	3	4	7	8	15	11	1	110	88	0.0022
13 x 16	4.5	3.7	3	3	3	4	6	10	16	13	2	110	90	0.0023
14 x 18	6.3	5.3	3	4	4	5	11	15	26	22	3	112	87	0.0049
15 x 19	6.3	5.3	3	4	4	5	11	15	26	25	3	111	88	0.0053
16 x 20	6.3	5.3	3	4	4	5	10	15	25	26	3	102	81	0.0055
17 x 21	6.3	5.3	3	4	4	5	10	16	26	30	3	104	84	0.0058
18 x 22	6.3	5.3	3	4	4	5	9	17	26	33	3	102	83	0.0061
19 x 24	6.3	5.3	3	4	4	5	13	19	32	40	4	111	88	0.0078
20 x 25	6.3	5.3	3	4	4	5	12	20	32	44	4	110	88	0.0082
22 x 26	6.3	5.3	3	4	4	5	9	21	30	50	4	103	87	0.0072
24 x 28	6.3	5.3	3	4	4	5	8	26	34	68	5	118	101	0.0079
25 x 30	6.3	5.3	3	4	4	5	10	27	37	75	6	120	100	0.01
28 x 32	6.3	5.3	3	4	4	5	7	30	37	90	6	115	101	0.009
30 x 35	6.3	5.3	3	4	4	5	8	31	39	100	6	111	95	0.012
32 x 36	6.3	5.3	3	4	4	5	8	34	42	120	7	117	104	0.01
35 x 40	7	6	3	4	4	5	13	42	55	160	9	115	101	0.02
36 x 42	7	6	4	5	5	6	15	43	58	170	9	116	99	0.02
38 x 44	7	6	4	5	5	6	14	46	60	190	10	116	100	0.02
40 x 45	8	6.6	4	5	5	6	14	53	67	230	11	116	103	0.02
42 x 48	8	6.6	4	5	5	6	16	57	73	260	12	118	104	0.03
45 x 52	10	8.6	4	5	5	6	26	80	106	390	17	119	103	0.05
48 x 55	10	8.6	4	5	5	6	25	82	107	430	17	115	100	0.05
50 x 57	10	8.6	4	5	5	6	24	86	110	470	18	116	102	0.05
55 x 62	10	8.6	4	5	5	6	22	97	119	580	21	118	105	0.05
56 x 64	12	10.4	4	5	5	6	29	122	151	740	26	120	105	0.07
60 x 68	12	10.4	4	5	6	7	27	129	156	840	28	119	105	0.07
63 x 71	12	10.4	4	5	6	7	26	134	160	920	29	118	105	0.08
65 x 73	12	10.4	4	5	6	7	25	142	167	1000	30	121	108	0.08
70 x 79	14	12.2	4	5	6	7	31	171	202	1300	37	115	102	0.11

<sup>1)</sup> Other sizes on request

\*\* Slotted type  
P<sub>O</sub> = Setting force  
P<sub>S</sub> = Clamping force  
P<sub>A</sub> = Total force

Please observe protection note ISO 16016.	Drawn: 2017-11-29 Shg/Jh	Replacing: KTR-N dated 2017-04-27
	Verified: 2017-11-29 Shg	Replaced by:

**1 Technical data**

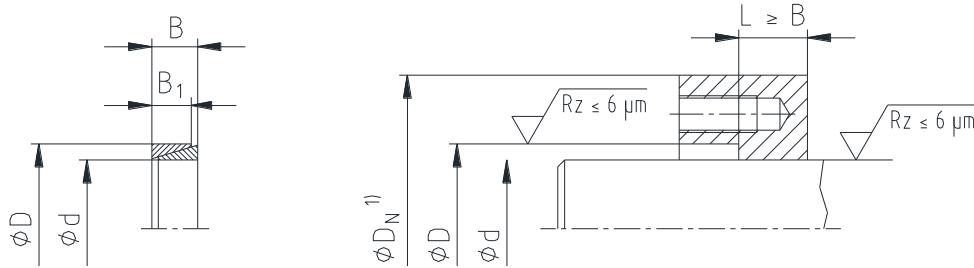

1) Dimension  $D_N$ : For calculation of hub see catalogue "Drive Technology"

**Tolerances for d and D**  
 $d \leq 38 \text{ mm} = d \text{ h}6/D \text{ H}7$   
 $d > 38 \text{ mm} = d \text{ h}8/D \text{ H}8$

Illustration 1: CLAMPEX® KTR 150

**Table 1: Technical data**

Dimensions [mm]			Distance dimension A [mm]				Clamping screws clamping force required $\mu_{\text{total}} = 0.14$			Transmittable torque or axial force		Surface pressure between clamp- ing set [N/mm <sup>2</sup> ]		Weight ~ kg
d x D <sup>1)</sup>	B	B <sub>1</sub>	Clamping elements				P <sub>O</sub> [kN]	P <sub>S</sub> [kN]	P <sub>A</sub> = P <sub>O</sub> + P <sub>S</sub> [kN]	T [Nm]	F <sub>ax</sub> [kN]	Shaft P <sub>W</sub>	Hub P <sub>N</sub>	
			1	2	3	4								
71 x 80	14	12.2	4	5	6	7	31	181	212	1400	39	121	107	0.11
75 x 84	14	12.2	4	5	6	7	34	184	218	1500	40	116	104	0.12
80 x 91	17	15	5	6	7	8	48	241	289	2100	52	116	102	0.12
85 x 96	17	15	5	6	7	8	45	260	305	2400	56	117	104	0.2
90 x 101	17	15	5	6	7	8	43	276	319	2700	60	118	105	0.2
95 x 106	17	15	5	6	8	9	41	290	331	3000	63	118	105	0.22
100 x 114	21	18.7	5	6	8	9	61	386	447	4200	84	119	105	0.4
110 x 124	21	18.7	5	6	8	9	65	393	458	4700	85	110	98	0.4
120 x 134	21	18.7	5	6	8	9	60	391	451	5100	85	100	90	0.5
130 x 148	28	25.3	6	7	9	11	96	573	669	8100	124	101	88	0.85
140 x 158	28	25.3	6	7	9	11	89	618	707	9400	134	101	89	0.91
150 x 168	28	25.3	6	7	9	11	84	674	758	11000	146	103	92	0.97
160 x 178	28	25.3	6	7	9	11	79	833	912	14500	181	119	107	1.02
170 x 191	33	30	7	8	10	12	118	1054	1172	19500	229	119	106	1.5
180 x 201	33	30	7	8	10	12	112	1082	1194	21200	235	116	104	1.6
190 x 211	33	30	7	9	10	12	106	1166	1272	24100	253	118	106	1.7
200 x 224	38	34.5	7	9	11	13	133	1425	1558	31000	310	119	106	2.3
210 x 234	38	34.5	7	9	11	13	127	1532	1659	35000	333	122	110	2.5
220 x 244	38	34.5	7	9	11	13	122	1587	1709	38000	345	121	109	2.5
230 x 257	43	39.5	7	9	12	14	165	1579	1744	39500	343	100	90	3.4
240 x 267	43	39.5	7	9	12	14	158	1801	1959	47000	391	110	99	3.5
250 x 280	48	44	8	10	13	16	188	1912	2100	52000	416	100	90	4.7
260 x 290	48	44	8	10	13	16	181	1997	2178	56500	434	101	90	4.8
270 x 300	48	44	8	10	13	16	174	2077	2251	61000	451	101	91	4.9
280 x 313	53	49	9	11	14	17	205	2381	2586	72500	517	100	90	6.3
290 x 323	53	49	9	11	14	17	221	2457	2678	77500	534	100	90	6.5
300 x 333	53	49	9	11	14	17	214	2544	2758	83000	553	100	90	6.7
320 x 360	65	59	10	15	20	25	291	3275	3566	114000	712	100	89	10.9
340 x 380	65	59	10	15	20	25	275	3474	3749	128500	755	100	89	11.5
360 x 400	65	59	10	15	20	25	261	3677	3938	144000	800	100	90	12.2
380 x 420	65	59	10	15	20	25	269	3870	4139	160000	842	100	90	12.8
400 x 440	65	59	10	15	20	25	256	4091	4347	178000	890	100	91	13.5
420 x 460	65	59	10	15	20	25	244	4290	4534	196000	933	100	91	14.1
440 x 480	65	59	10	15	20	25	234	4492	4726	215000	977	100	92	14.7

<sup>1)</sup> Other sizes on request

P<sub>O</sub> = Setting force  
P<sub>S</sub> = Clamping force  
P<sub>A</sub> = Total force

Please observe protection note ISO 16016.	Drawn:	2017-11-29 Shg/Jh	Replacing:	KTR-N dated 2017-04-27
	Verified:	2017-11-29 Shg	Replaced by:	



## 1 Technical data

### Calculation of torque with clamping elements positioned in a row multiple times

1 clamping element	$T_{\text{total}} = T_{\text{single}} \cdot 1.00$
2 clamping elements	$T_{\text{total}} = T_{\text{single}} \cdot 1.55$
3 clamping elements	$T_{\text{total}} = T_{\text{single}} \cdot 1.85$
4 clamping elements	$T_{\text{total}} = T_{\text{single}} \cdot 2.02$

### Calculation of pressure flange

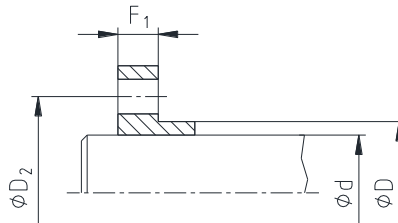
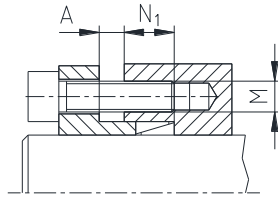

Illustration 2: Dimensions for calculation of pressure flange

### **Recommended dimensions of pressure flanges:**

$$N_1 \text{ [mm]} \geq 1.5 \cdot B$$

$$D_2 \text{ [mm]} = D + 12 + M$$

$$F_1 \text{ [mm]} = M \cdot 1.3 \text{ (with screws 8.8)}$$

$$F_1 \text{ [mm]} = M \cdot 1.8 \text{ (with screws 10.9/12.9)}$$

## 2 Advice

### 2.1 General advice

Please read through these operating/assembly instructions carefully before you mount the clamping set.

Please pay special attention to the safety instructions!

The operating/assembly instructions are part of your product. Please store them carefully and close to the clamping set.

The copyright for these operating/assembly instructions remains with KTR.

### 2.2 Safety and advice symbols



**Warning of potentially explosive atmospheres**

This symbol indicates notes which may contribute to preventing bodily injuries or serious bodily injuries that may result in death caused by explosion.



**Warning of personal injury**

This symbol indicates notes which may contribute to preventing bodily injuries or serious bodily injuries that may result in death.



**Warning of product damages**

This symbol indicates notes which may contribute to preventing material or machine damage.



**General advice**

This symbol indicates notes which may contribute to preventing adverse results or conditions.



**2 Advice**

**2.3 General hazard warnings**



**With assembly and disassembly of the clamping set it has to be made sure that the entire drive train is secured against accidental switch-on. You may be seriously hurt by rotating parts. Please make absolutely sure to read through and observe the following safety indications.**

- All operations on and with the clamping set have to be performed taking into account "safety first".
- Please make sure to switch off the power pack before you perform your work on the clamping set.
- Secure the power pack against accidental switch-on, e. g. by providing warning signs at the place of switch-on or removing the fuse for current supply.
- Do not reach into the operation area of the machine as long as it is in operation.
- Please secure the rotating drive components against accidental contact. Please provide for the necessary protection devices and covers.

**2.4 Intended use**

You may only assemble and disassemble the clamping set if you

- have carefully read through the operating/assembly instructions and understood them
- had technical training
- are authorized by your company

The clamping set may only be used in accordance with the technical data (see table 1). Unauthorized modifications on the clamping set are not admissible. We will not assume liability for any damage that may arise. In the interest of further development we reserve the right for technical modifications.

The clamping set described in here corresponds to the technical status at the time of printing of these operating/assembly instructions.

**3 Storage, transport and packaging**

**3.1 Storage**

The clamping sets are supplied in preserved condition and can be stored at a dry and covered place for 6 - 9 months.



**Humid storage rooms are not suitable. Please make sure that condensation is not generated.**

**3.2 Transport and packaging**



**In order to avoid any injuries and any kind of damage please always make use of proper transport and lifting equipment.**

The clamping sets are packed differently each depending on size, quantity and kind of transport. Unless otherwise contractually agreed, packaging will follow the in-house packaging specifications of KTR.

Please observe protection note ISO 16016.	Drawn:	2017-11-29 Shg/Jh	Replacing:	KTR-N dated 2017-04-27
	Verified:	2017-11-29 Shg	Replaced by:	

**4 Assembly**

Generally the clamping set is supplied in mounted condition. Before assembly the clamping set has to be inspected for completeness.

**4.1 Components of clamping set**

**Components of clamping set CLAMPEX® KTR 150**

Component	Quantity	Description
1	1	Internal taper ring
2	1	External taper ring

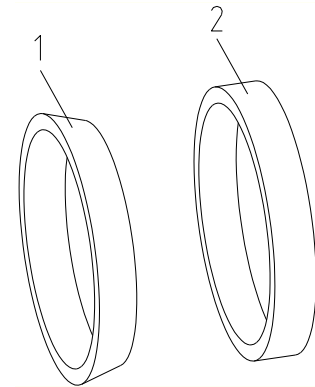

Illustration 3: Components of clamping set



**Dirty or used clamping elements have to be disassembled and cleaned before assembly. Afterwards apply thin fluid oil lightly (e. g. Ballistol Universal oil or Klüber Quietsch-Ex).**

**4 Assembly**

**4.2 Assembly of clamping set**

- Inspect the fit of shaft and hub for the tolerance specified (see illustration 1).
- Clean the hub bore and shaft and afterwards apply a thin-fluid oil (e. g. Ballistol Universal oil or Klüber Quietsch-Ex).



**Oils and greases with molybdenum disulphide or other high-pressure additives, additives of Teflon and silicone as well as internal lubricants reducing the coefficient of friction significantly must not be used. When mounting the tapers of the clamping set free from oil the tabular and calculated parameters deviate.**

- Shift the hub onto the shaft.
- If there is a recess, it has to be bridged via a distance ring (see illustration 4 and 5). The distance ring can be done without if the recess is missing.

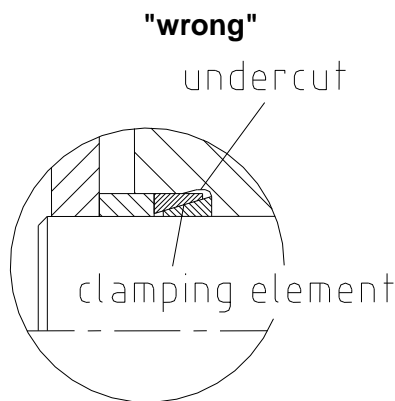

Illustration 4: Clamping element in recess

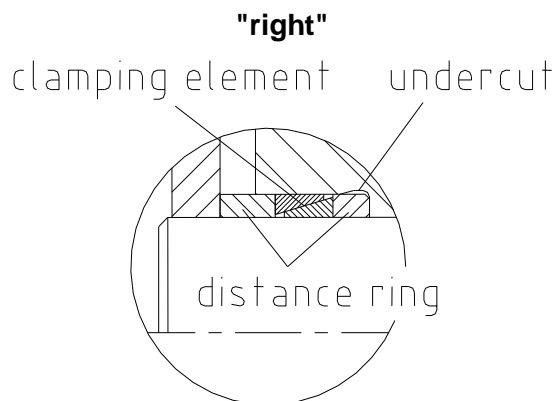

Illustration 5: Distance ring in recess

- If several KTR 150 ring pairs (4 ring pairs at the maximum) are installed, make sure uniform arrangement of KTR 150 elements (see illustration 6 and 7).

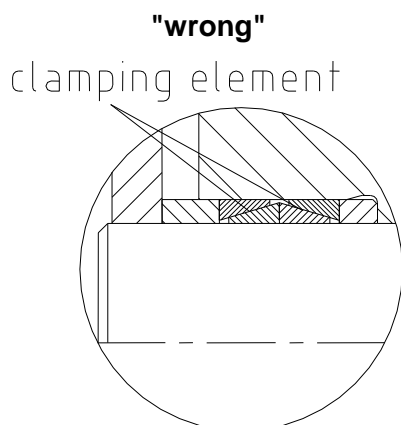

Illustration 6: Wrong installation of several clamping elements

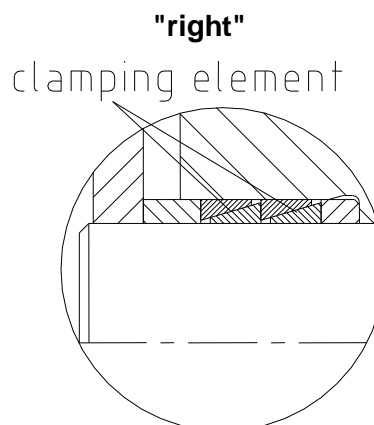

Illustration 7: Installation of several clamping elements

- Observe distance dimension A (see illustration 8, 9 and 10).

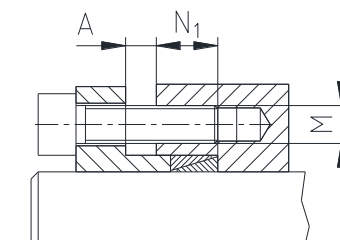

Illustration 8: Observe distance dimension A

Please observe protection note ISO 16016.	Drawn: 2017-11-29 Shg/Jh	Replacing: KTR-N dated 2017-04-27
	Verified: 2017-11-29 Shg	Replaced by:

**4 Assembly**

**4.2 Assembly of clamping set**

- Do not assemble the clamping element in a clamping position, make sure easy shifting.
- The pressure flange can optionally be assembled either with a collar or distance ring. Make sure easy shifting as well.
- Tighten the clamping screws lightly and align the clamping set.
- Tighten the screws evenly crosswise step by step to the tightening torque  $T_A$  specified in table 2. Repeat this process until all clamping screws have reached the tightening torque. Inspect the remaining gap A for uniformity (see illustration 9 and 10).
- If possible, repeat the previous item after test run.

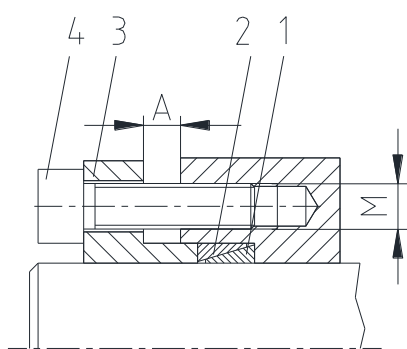

Illustration 9: **Assembly 1**  
Clamping on hub side

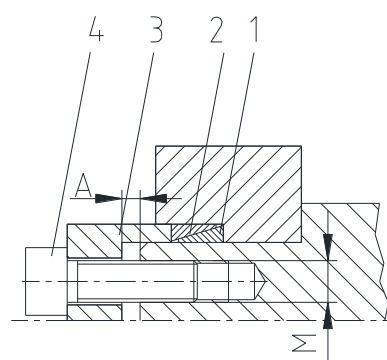

Illustration 10: **Assembly 2**  
Clamping on shaft side

Component	Quantity	Description	Component	Quantity	Description
1	1	Internal taper ring	4	Acc. to selection	Cap screw DIN EN ISO 4762
2	1	External taper ring			
3	1	Pressure flange			



**During assembly the hub is not displaced axially towards the shaft with KTR 150.**

**Table 2: Screws**

Dimensions M	Preload force $F_V$ and tightening torque $T_A$ with $\mu_{total} = 0.14$					
	Preload force $F_V$ [N]			Tightening torque $T_A$ [Nm]		
	8.8	10.9	12.9	8.8	10.9	12.9
M3	2210	3110	3730	1.34	1.89	2.25
M4	3900	5450	6550	2.9	4.1	4.9
M5	6350	8950	10700	6	8.5	10
M6	9000	12600	15100	10	14	17
M8	16500	23200	27900	25	35	41
M10	26200	36900	44300	49	69	83
M12	38300	54000	64500	86	120	145
M14	52500	74000	88500	135	190	230
M16	73000	102000	123000	210	295	355
M18	88000	124000	148000	290	405	485
M20	114000	160000	192000	410	580	690
M22	141000	199000	239000	550	780	930
M24	164000	230000	276000	710	1000	1200
M27	215000	302000	363000	1050	1500	1800
M30	262000	368000	442000	1450	2000	2400

Please observe protection note ISO 16016.

Drawn: 2017-11-29 Shg/Jh  
Verified: 2017-11-29 Shg

Replacing: KTR-N dated 2017-04-27  
Replaced by:





## 4 Assembly

### 4.3 Disassembly of clamping set



Parts released or falling down may cause injury to persons or damage on the machine. Secure the components before disassembly.

- Untighten and unscrew all clamping screws evenly one after another.
- The clamping elements are not self-locking. If the internal and external taper ring are still stuck, the process of releasing should be initiated by putting light pressure on the hub in several positions on the circumference or the hub.
- Remove the clamping elements released between shaft and hub.



If these hints are not observed or operating conditions are not considered with the selection of the clamping element, the operation of the clamping element may be affected.

## 5 Disposal

In respect of environmental protection we would ask you to dispose of the packaging or products on termination of their service life in accordance with the legal regulations and standards that apply, respectively. All clamping sets consist of metal. Any metal components have to be cleaned and disposed of by scrap metal.

## 6 Spares inventory, customer service addresses

A basic requirement to ensure the readiness for use of the drive components is a stock of some clamping sets on site.

Contact addresses of the KTR partners for spare parts and orders can be obtained from the KTR homepage at [www.ktr.com](http://www.ktr.com).



**KTR does not assume any liability or warranty for the use of spare parts and accessories which are not provided by KTR and for the damages which may incur as a result.**

## 7 Advice regarding the use in potentially explosive atmospheres according to EU directive 2014/34/EU

If used in potentially explosive atmospheres the type and size of clamping set (for category 3 only) has to be selected such that the difference between the peak torque of the machine including all operating parameters and the rated torque of the clamping hub at least corresponds to a safety factor of  $s = 2$ .

**CLAMPEX®** clamping sets are not part of directive 2014/34/EU, since

- this product is a torsionally rigid, backlash-free, frictionally engaged connection with one or more taper clamping ring(s) by means of several screws.  
**(Clamping screws have to be secured, e. g. by means of a medium strength adhesive.)**
- due to the design of clamping sets a fracture/failure is not likely (frictional heat is only caused by improper assembly/tightening torques, i. e. not with intended use).

Any questions? Please contact us.