

CLAMPEX® KTR 203

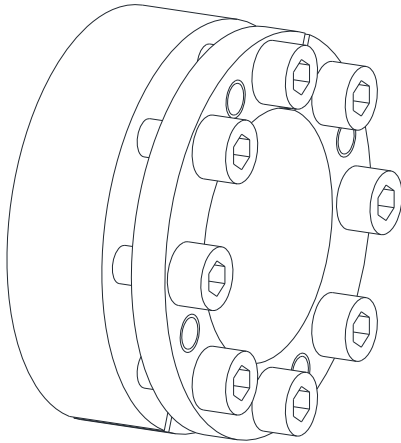

CLAMPEX® KTR 206

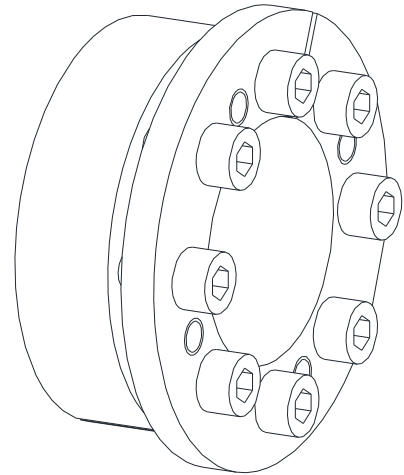

The **CLAMPEX® clamping set** is a frictionally engaged, detachable shaft-hub-connection for cylindrical shafts and bores without feather key.

Table of contents

1	Technical data	2
2	Advice	6
2.1	General advice	6
2.2	Safety and advice symbols	6
2.3	General hazard warnings	6
2.4	Intended use	6
3	Storage, transport and packaging	7
3.1	Storage	7
3.2	Transport and packaging	7
4	Assembly	7
4.1	Components of clamping set	7
4.2	Assembly of the clamping set	8
4.3	Disassembly of clamping set	9
5	Disposal	9
6	Spares inventory, customer service addresses	9
7	Advice regarding the use in  hazardous locations according to EU directive 2014/34/EU	10



1 Technical data

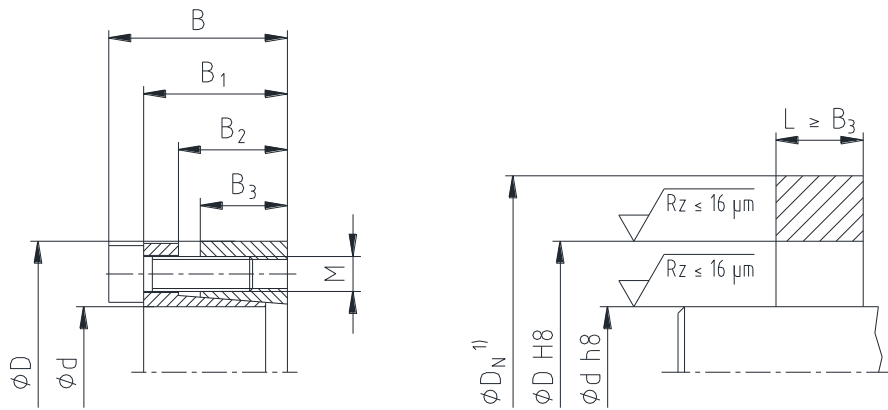

Illustration 1: Dimensions of CLAMPEX® KTR 203

- 1) Dimension D_N : For calculation of hub see catalogue "Drive Technology"
- 2) These are the maximum screw tightening torques. They can be reduced by a maximum of 40 % of the figures specified, with T , F_{ax} , P_W and P_N declining proportionally.

Table 1: CLAMPEX® KTR 203

Dimensions [mm]						Clamping screws DIN EN ISO 4762 - 12.9 $\mu_{total} = 0.14$				Transmittable Torque or axial force		Surface pressure between Clamping set [N/mm ²]		Weight [kg]
d x D	B	B ₁	B ₂	B ₃	D ₁	M	Length	Z Quantity	T _A ²⁾ [Nm]	T [Nm]	F _{ax} [kN]	Shaft P _W	Hub P _N	
18 x 47	34	28	22	17	53	M6	20	6	14	370	41	356	136	0.3
19 x 47	34	28	22	17	53	M6	20	6	14	390	41	337	136	0.3
20 x 47	34	28	22	17	53	M6	20	6	14	410	41	320	136	0.3
22 x 47	34	28	22	17	53	M6	20	6	14	450	41	290	136	0.3
24 x 50	34	28	22	17	56	M6	20	6	14	490	41	265	127	0.3
25 x 50	34	28	22	17	56	M6	20	6	14	510	41	255	127	0.3
28 x 55	34	28	22	17	61.4	M6	20	6	14	570	41	227	116	0.3
30 x 55	34	28	22	17	61.4	M6	20	6	14	610	41	212	115	0.3
32 x 60	34	28	22	17.5	67	M6	20	8	14	880	55	261	139	0.4
35 x 60	34	28	22	17.5	67	M6	20	8	14	960	55	238	139	0.3
38 x 65	34	28	22	17.5	72	M6	20	8	14	1000	53	210	123	0.4
40 x 65	34	28	22	17.5	72	M6	20	8	14	1100	55	208	128	0.4
42 x 75	41	33	25	20	84	M8	25	8	35	2200	105	331	185	0.6
45 x 75	41	33	25	20	84	M8	25	8	35	2400	107	314	189	0.6
48 x 80	41	33.5	24	20	89	M8	25	8	35	2500	104	288	173	0.7
50 x 80	41	33.5	24	20	89	M8	25	8	35	2600	104	276	172	0.7
55 x 85	41	33.5	24	20	94	M8	25	8	35	2900	105	254	165	0.7
60 x 90	41	33.5	24	20	99	M8	25	8	35	3100	103	228	152	0.8
65 x 95	41	33.5	24	20	104	M8	25	8	35	3400	105	213	146	0.8
70 x 110	50	40	29	24	119	M10	30	8	70	6000	171	271	172	1.5
75 x 115	50	40	29	24	124	M10	30	8	70	6400	171	252	164	1.6
80 x 120	50	40	29	24	129	M10	30	8	70	6800	170	235	157	1.7
85 x 125	50	40	29	24	134	M10	30	10	70	9000	212	275	187	1.8
90 x 130	50	40	29	24	139	M10	30	10	70	9600	213	262	181	1.9
95 x 135	50	40	29	24	144	M10	30	10	70	10200	215	250	176	2.0
100 x 145	56	44	31	25.5	154	M12	30	8	115	12000	240	250	172	2.6
110 x 155	56	44	31	25.5	164	M12	30	8	115	13000	236	224	159	2.8
120 x 165	56	44	31	26	174	M12	30	9	115	16000	267	227	165	3.6
130 x 180	64	52	39	34	189	M12	30	12	115	23000	354	212	153	4.4
140 x 190	68	54	39	34	199	M14	40	9	185	25000	357	199	147	4.9
150 x 200	68	54	39	34	209	M14	40	10	185	30000	400	208	156	5.2
160 x 210	68	54	39	34	219	M14	40	12	185	38800	485	236	180	5.6
170 x 225	78	64	49	44	234	M14	40	12	185	41300	486	172	130	6.9

1 Technical data

Page 2 continued:

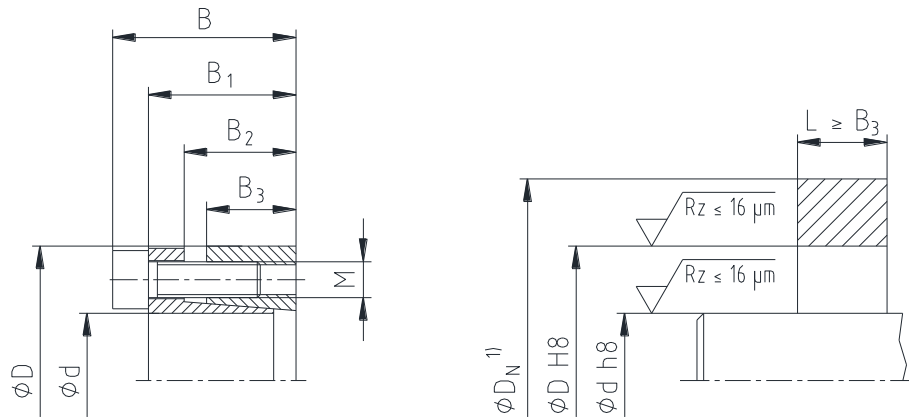

Illustration 1: Dimensions of CLAMPEX® KTR 203

- 1) Dimension D_N : For calculation of hub see catalogue "Drive Technology"
- 2) These are the maximum screw tightening torques. They can be reduced by a maximum of 40 % of the figures specified, with T , F_{ax} , P_W and P_N declining proportionally.

Table 1: CLAMPEX® KTR 203

Dimensions [mm]						Clamping screws DIN EN ISO 4762 - 12.9 $\mu_{total} = 0.14$				Transmittable Torque or axial force		Surface pressure between Clamping set [N/mm ²]		Weight [kg]
d x D	B	B ₁	B ₂	B ₃	D ₁	M	Length	Z Quantity	T _A ²⁾ [Nm]	T [Nm]	F _{ax} [kN]	Shaft P _W	Hub P _N	
180 x 235	78	64	49	44	244	M14	40	12	185	43700	486	163	125	8.5
190 x 250	78	64	49	43.5	259	M14	40	15	185	57700	607	195	148	9.0
200 x 260	78	64	49	43.5	269	M14	40	15	185	60700	607	185	142	9.6
220 x 285	88	72	57	50	294	M16	40	12	290	77300	703	169	131	13.4
240 x 305	88	72	57	50	314	M16	40	15	290	105400	878	194	153	14.5
260 x 325	88	72	57	50	334	M16	40	18	290	137000	1054	215	172	16.1
280 x 355	102	84	66	60	364	M18	60	16	400	160300	1145	181	143	23.4
300 x 375	102	84	66	60	384	M18	60	18	400	193200	1288	190	152	25.3
320 x 405	121	101	81	74	414	M20	74	18	580	269300	1683	189	149	36.9
340 x 425	121	101	81	74	434	M20	74	21	580	333800	1964	207	166	39.0
360 x 455	138	116	93	86	464	M22	86	18	780	375700	2087	179	141	54.0
380 x 475	138	116	93	86	484	M22	86	21	780	462700	2435	198	158	56.2
400 x 495	138	116	93	86	504	M22	86	21	780	487000	2435	188	152	58.9

1 Technical data

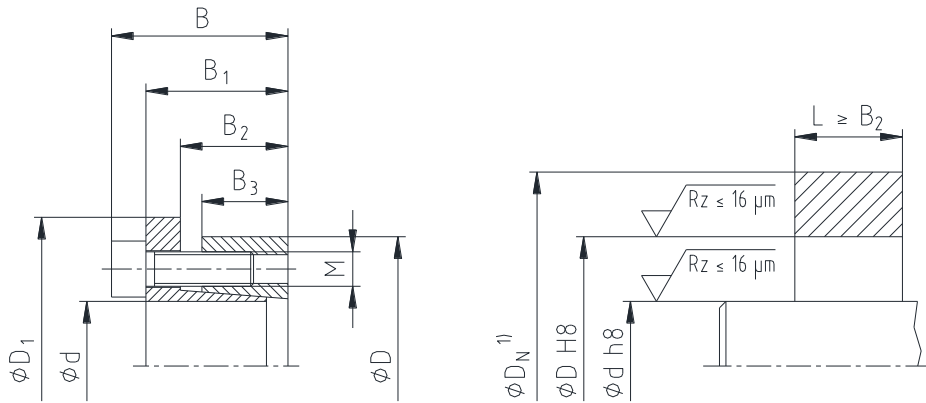

Illustration 2: Dimensions of CLAMPEX® KTR 206

- 1) Dimension D_N : For calculation of hub see catalogue "Drive Technology"
- 2) These are the maximum screw tightening torques. They can be reduced by a maximum of 40 % of the figures specified, with T , F_{ax} , P_W and P_N declining proportionally.

Table 2: CLAMPEX® KTR 206

Dimensions [mm]						Clamping screws DIN EN ISO 4762 - 12.9 $\mu_{total} = 0.14$				Transmittable Torque or axial force		Surface pressure between Clamping set [N/mm ²]		Weight [kg]
d x D	B	B ₁	B ₂	B ₃	D ₁	M	Length	Z Quantity	T _A ²⁾ [Nm]	T [Nm]	F _{ax} [kN]	Shaft P _W	Hub P _N	
18 x 47	34	28	22	17	53	M6	20	6	17	290	32	279	107	0.3
19 x 47	34	28	22	17	53	M6	20	6	17	300	32	259	105	0.3
20 x 47	34	28	22	17	53	M6	20	6	17	320	32	250	106	0.3
22 x 47	34	28	22	17	53	M6	20	6	17	350	32	226	106	0.3
24 x 50	34	28	22	17	56	M6	20	6	17	390	32	211	101	0.3
25 x 50	34	28	22	17	56	M6	20	6	17	400	32	200	100	0.3
28 x 55	34	28	22	17	61.4	M6	20	6	17	450	32	179	91	0.4
30 x 55	34	28	22	17	61.4	M6	20	6	17	490	33	170	93	0.3
32 x 60	34	28	22	17.5	67	M6	20	8	17	700	44	207	111	0.3
35 x 60	34	28	22	17.5	67	M6	20	8	17	760	43	188	110	0.4
38 x 65	34	28	22	17.5	72	M6	20	8	17	820	43	172	101	0.5
40 x 65	34	28	22	17.5	72	M6	20	8	17	870	44	165	101	0.4
42 x 75	41	33	25	20	84	M8	25	8	41	1700	81	256	143	0.7
45 x 75	41	33	25	20	84	M8	25	8	41	1800	80	236	141	0.7
48 x 80	41	33.5	24	20	89	M8	25	8	41	1900	79	219	131	0.8
50 x 80	41	33.5	24	20	89	M8	25	8	41	2000	80	212	133	0.8
55 x 85	41	33.5	24	20	94	M8	25	8	41	2200	80	193	125	0.9
60 x 90	41	33.5	24	20	99	M8	25	8	41	2400	80	177	118	0.9
65 x 95	41	33.5	24	20	104	M8	25	8	41	2600	80	163	112	0.9
70 x 110	50	40	29	24	119	M10	30	8	83	4600	131	208	132	1.6
75 x 115	50	40	29	24	124	M10	30	8	83	5000	133	196	128	1.7
80 x 120	50	40	29	24	129	M10	30	8	83	5300	133	183	122	1.9
85 x 125	50	40	29	24	134	M10	30	10	83	7000	165	214	146	2.0
90 x 130	50	40	29	24	139	M10	30	10	83	7400	164	202	140	2.0
95 x 135	50	40	29	24	144	M10	30	10	83	7800	164	191	134	2.3
100 x 145	56	44	31	25.5	154	M12	30	8	145	9700	194	202	139	2.8
110 x 155	56	44	31	25.5	164	M12	30	8	145	10700	195	184	131	3.1
120 x 165	56	44	31	26	174	M12	30	9	145	13100	218	186	135	3.2
130 x 180	64	52	39	34	189	M12	30	12	145	19000	292	175	127	4.6
140 x 190	68	54	39	34	199	M14	40	9	230	20500	293	163	120	5.0
150 x 200	68	54	39	34	209	M14	40	10	230	24500	327	170	127	5.2
160 x 210	68	54	39	34	219	M14	40	12	230	31300	391	191	145	5.6

1 Technical data

Page 4 continued:

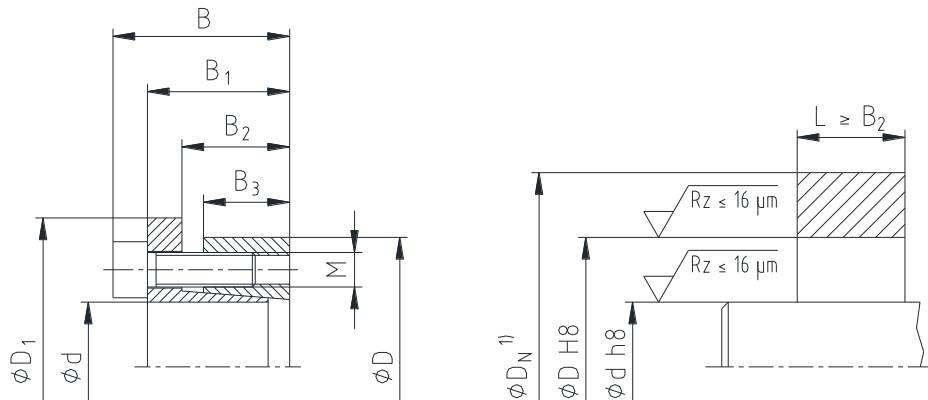

Illustration 2: Dimensions of CLAMPEX® KTR 206

- 1) Dimension D_N : For calculation of hub see catalogue "Drive Technology"
- 2) These are the maximum screw tightening torques. They can be reduced by a maximum of 40 % of the figures specified, with T , F_{ax} , P_W and P_N declining proportionally.

Table 2: CLAMPEX® KTR 206

Dimensions [mm]						Clamping screws DIN EN ISO 4762 - 12.9 $\mu_{total} = 0.14$				Transmittable Torque or axial force		Surface pressure between Clamping set [N/mm ²]		Weight [kg]
d x D	B	B ₁	B ₂	B ₃	D ₁	M	Length	Z Quantity	T _A ²⁾ [Nm]	T [Nm]	F _{ax} [kN]	Shaft P _W	Hub P _N	
170 x 225	78	64	49	44	234	M14	40	12	230	33200	391	139	105	6.5
180 x 235	78	64	49	44	244	M14	40	12	230	35000	389	130	100	8.5
190 x 250	78	64	49	43.5	259	M14	40	15	230	46500	489	157	119	9.0
200 x 260	78	64	49	43.5	269	M14	40	15	230	49000	490	149	115	9.6
220 x 285	88	72	57	50	294	M16	40	12	360	57100	519	125	97	14.0
240 x 305	88	72	57	50	314	M16	40	15	360	77800	648	143	113	15.1
260 x 325	88	72	57	50	334	M16	40	18	360	101200	778	159	127	16.2
280 x 355	102	84	66	60	364	M18	50	16	480	113300	809	128	101	25.6
300 x 375	102	84	66	60	384	M18	50	18	480	136500	910	134	107	25.5
320 x 405	121	101	81	74	414	M20	50	18	690	191000	1194	134	106	37.9
340 x 425	121	101	81	74	434	M20	50	21	690	237000	1394	147	118	38.3
360 x 455	138	116	93	86	464	M22	60	18	930	264000	1467	126	99	53.3
380 x 475	138	116	93	86	484	M22	60	21	930	325000	1711	139	111	57.6
400 x 495	138	116	93	86	504	M22	60	21	930	342000	1710	132	107	60.3

Tolerances, surfaces

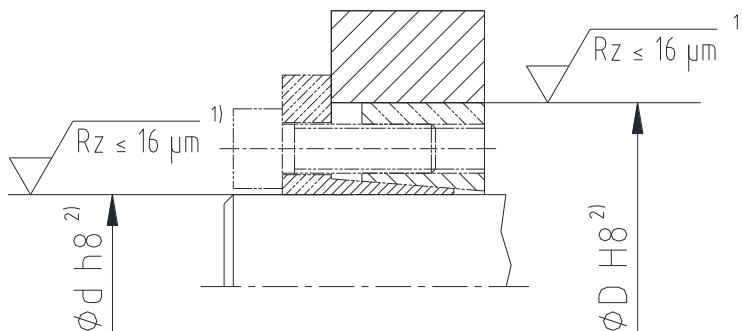

Illustration 3: Tolerances and surfaces (example: CLAMPEX® KTR 206)

- 1) One proper turning process is sufficient ($R_z \leq 16 \mu\text{m}$).
- 2) Highest permissible tolerance of hub or shaft.

Please observe protection note ISO 16016.	Drawn:	2016-09-09 Shg/Jh	Replacing:	KTR-N dated 15.09.15
	Verified:	2016-09-09 Shg	Replaced by:	

2 Advice

2.1 General advice

Please read through these operating/assembly instructions carefully before you mount the clamping set. Please pay special attention to the safety instructions! The operating/assembly instructions are part of your product. Please store them carefully and close to the clamping set. The copyright for these operating/assembly instructions remains with KTR.

2.2 Safety and advice symbols



Warning of potentially explosive atmospheres

This symbol indicates notes which may contribute to preventing bodily injuries or serious bodily injuries that may result in death caused by explosion.



Warning of personal injury

This symbol indicates notes which may contribute to preventing bodily injuries or serious bodily injuries that may result in death.



Warning of product damages

This symbol indicates notes which may contribute to preventing material or machine damage.



General advice

This symbol indicates notes which may contribute to preventing adverse results or conditions.

2.3 General hazard warnings



With assembly and disassembly of the clamping set it has to be made sure that the entire drive train is secured against accidental switch-on. You may be seriously hurt by rotating parts. Please make absolutely sure to read through and observe the following safety indications.

- All operations on and with the clamping set have to be performed taking into account "safety first".
- Please make sure to switch off the power pack before you perform your work on the clamping set.
- Secure the power pack against accidental switch-on, e. g. by providing warning signs at the place of switch-on or removing the fuse for current supply.
- Do not reach into the operation area of the machine as long as it is in operation.
- Please secure the rotating drive components against accidental contact. Please provide for the necessary protection devices and covers.

2 Advice

2.4 Intended use

You may only assemble and disassemble the clamping set if you

- have carefully read through the operating/assembly instructions and understood them
- had technical training
- are authorized by your company

The clamping set may only be used in accordance with the technical data (see chapter 1). Unauthorized modifications on the clamping set are not admissible. We will not assume liability for any damage that may arise. In the interest of further development we reserve the right for technical modifications.

The clamping set described in here corresponds to the technical status at the time of printing of these operating/assembly instructions.

Please observe protection note ISO 16016.	Drawn: 2016-09-09 Shg/Jh	Replacing: KTR-N dated 15.09.15
	Verified: 2016-09-09 Shg	Replaced by:

3 Storage, transport and packaging

3.1 Storage

The clamping sets are supplied in preserved condition and can be stored at a dry and roofed place for 6 - 9 months.



**Humid storage rooms are not suitable.
 Please make sure that condensation is not generated.**

3.2 Transport and packaging



In order to avoid any injuries and any kind of damage please always make use of proper transport and lifting equipment.

The clamping sets are packed differently each depending on size, quantity and kind of transport. Unless otherwise contractually agreed, packaging will follow the in-house packaging specifications of KTR.

4 Assembly

Generally the clamping set is supplied in mounted condition. Before assembly the clamping set has to be inspected for completeness.

4.1 Components of clamping set

Components of clamping set CLAMPEX® KTR 203 / KTR 206

Component	Quantity	Description
1	1	Outer ring (slit)
2	1	Inner ring (slit)
3	see table 1 and 2	Cap screw DIN EN ISO 4762

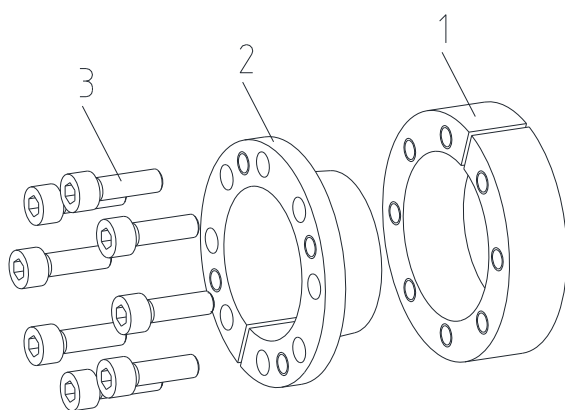

Illustration 4: CLAMPEX® KTR 203

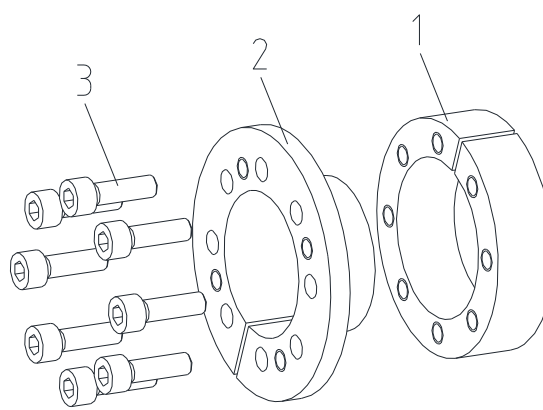

Illustration 5: CLAMPEX® KTR 206

**4 Assembly****4.2 Assembly of the clamping set**

- Inspect the fit of shaft and hub for the tolerance specified (illustration 3).
- Clean the surfaces of the clamping set marked in illustration 6 as well as of shaft and hub and afterwards apply thin fluid oil lightly (e. g. Ballistol Universal oil or Klüber Quietsch-Ex).

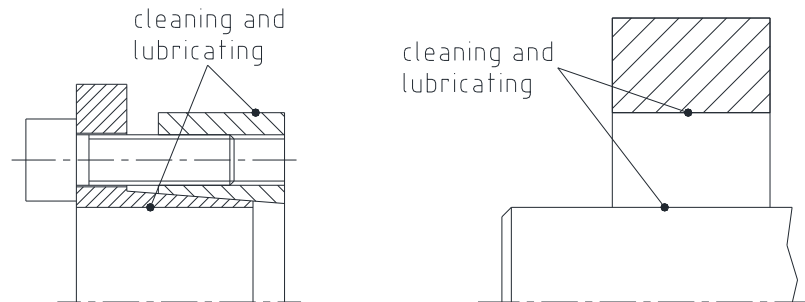

Illustration 6: Cleaning and lubricating the surfaces (example: CLAMPEX® KTR 206)



Oils and greases with molybdenum disulphide or other high-pressure additives, additives of Teflon and silicone as well as internal lubricants reducing the coefficient of friction significantly must not be used. When mounting the tapers of the clamping set free from oil the tabular and calculated parameters deviate.

- Unscrew the clamping screws by several revolutions so that the external ring lightly detaches from the internal ring.
- To facilitate the assembly fasten the internal and external ring by two clamping screws each via the pull-off threads (see illustration 7). Afterwards insert the clamping set KTR 203 / KTR 206 between shaft and hub.

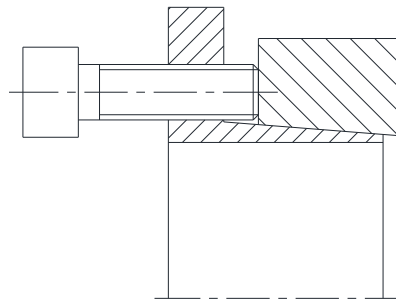

Illustration 7: Fastening the clamping set (example: CLAMPEX® KTR 206)

- Remove the clamping screws used for fastening and screw them into the thread of the external ring.
- Hand-tighten the clamping screws for the time being and align the internal clamping ring along with the hub.
- Please make sure with KTR 206 that the internal ring (component 2) for axial fastening fits the hub evenly.
- Tighten the clamping screws evenly crosswise step by step to the tightening torque specified in table 1 or 2. Repeat this process until all clamping screws have reached the tightening torque.



During assembly the hub is displaced axially towards the shaft with KTR 203.



4 Assembly

4.3 Disassembly of clamping set



**Driving components released or falling down may cause injury to persons or damage on the machine.
Secure the driving components before disassembly.**

- Untighten and unscrew all clamping screws evenly and one after another.
- Screw the clamping screws into the pull-off threads of the internal ring (component 2) (see illustration 8 and 9).
- Tighten the clamping screws evenly crosswise. Increase the pull-off torque stepwise until the external ring (component 1) and internal ring (component 2) are separated.
- Take out the clamping set released between shaft and hub.

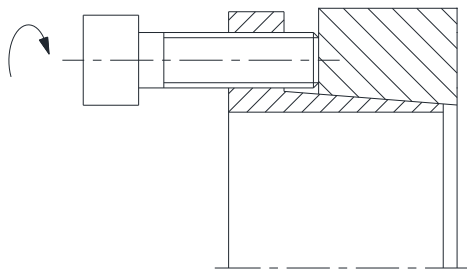

Illustration 8: Releasing the clamping set KTR 203

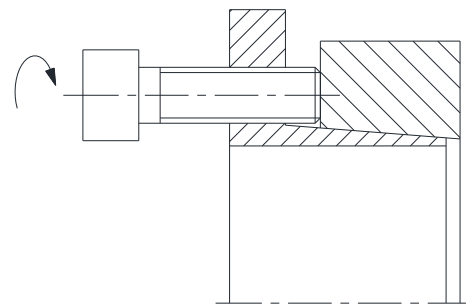

Illustration 9: Releasing the clamping set KTR 206



If these hints are not observed or operating conditions are not taken into account with the selection of the clamping set, the operation of the clamping set may be affected.



Used clamping sets have to be disassembled and cleaned before assembly. Afterwards apply thin fluid oil lightly (e. g. Ballistol Universal oil or Klüber Quietsch-Ex).

5 Disposal

In respect of environmental protection we would ask you to dispose of the packaging or products on termination of their service life in accordance with the legal regulations and standards that apply, respectively. All clamping sets consist of metal. Any metal components have to be cleaned and disposed of by scrap metal.

6 Spares inventory, customer service addresses

A basic requirement to ensure the readiness for use of the drive components is a stock of some clamping sets on site.

Contact addresses of the KTR partners for spare parts and orders can be obtained from the KTR homepage at www.ktr.com.



KTR does not assume any liability or warranty for the use of spare parts and accessories which are not provided by KTR and for the damages which may incur as a result.

Please observe protection note ISO 16016.	Drawn: 2016-09-09 Shg/Jh	Replacing: KTR-N dated 15.09.15
	Verified: 2016-09-09 Shg	Replaced by:

7 Advice regarding the use in  hazardous locations according to EU directive 2014/34/EU

If used in hazardous locations the type and size of the clamping set (for category 3 only) has to be selected such that the difference between the peak torque of the machine including all operating parameters and the rated torque of the clamping hub at least corresponds to a safety factor of $s = 2$.

CLAMPEX® clamping sets are not part of directive 2014/34/EU, since

- this product is a torsionally rigid, backlash-free, frictionally engaged connection with one or more taper clamping ring(s) by means of several screws.
(Clamping screws have to be secured, e. g. by means of a medium strength adhesive.)
- due to the design of clamping sets a fracture/failure is not likely (frictional heat is only caused by improper assembly/tightening torques, i. e. not with intended use).

Any questions? Please contact us.