

Complete Freewheels BA

with lever arm

with rollers or with sprag lift-off X

Morskate®

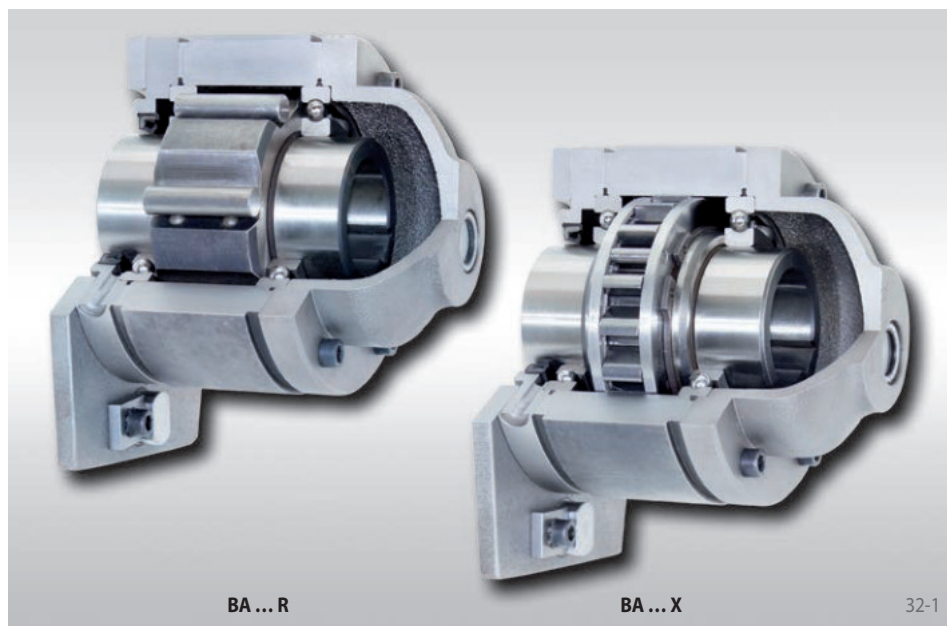

Application as

▶ Backstop

Features

Complete Freewheels BA with lever arm are sealed freewheels with ball bearings.

The freewheels BA have an end cover and are fitted to shaft ends. The oil filling is carried out after the freewheel has been fitted to the end of the shaft.

Besides the standard type, the type with sprag lift-off X is available for wearfree freewheeling operation at high speed rotating inner ring.

Nominal torques up to 57 500 Nm.

Bores up to 150 mm. A multitude of standardized bore diameters are available with short delivery times.

Application example

Complete Freewheel BA 45 SX as a backstop, arranged at the end of the intermediate shaft of a spur gearbox. The backdriving torque is supported by the lever arm with holding pin on the gearbox housing. If the holding pin is removed, the shaft can be turned in both directions. With the high shaft speed in normal operation (freewheeling operation), the type with sprag lift-off X is used; the sprags work in freewheeling operation without contact and hence are wear-free.

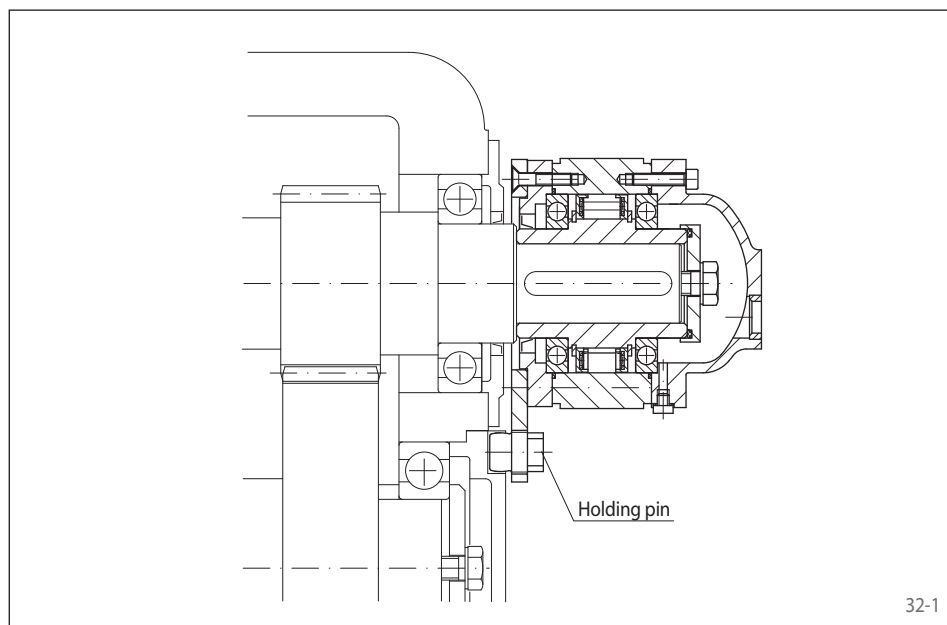

Any questions? Please contact us.

Morskate Aandrijvingen BV

Oosterveldsingel 47A
7558 PJ Hengelo (Ov)
The Netherlands

NL
T +31 (0)74 - 760 11 11
info@morskateaandrijvingen.nl
www.morskateaandrijvingen.nl

DE
T +49 692 - 222 34 95
info@morskateantriebstechnik.de
www.morskateantriebstechnik.de

EN
T +31 (0)74 - 760 11 11
info@morskatedrivetechnology.com
www.morskatedrivetechnology.com

Complete Freewheels BA

with lever arm
with rollers or with sprag lift-off X

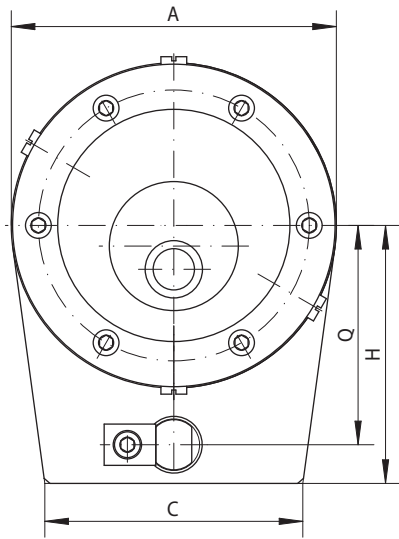

33-1

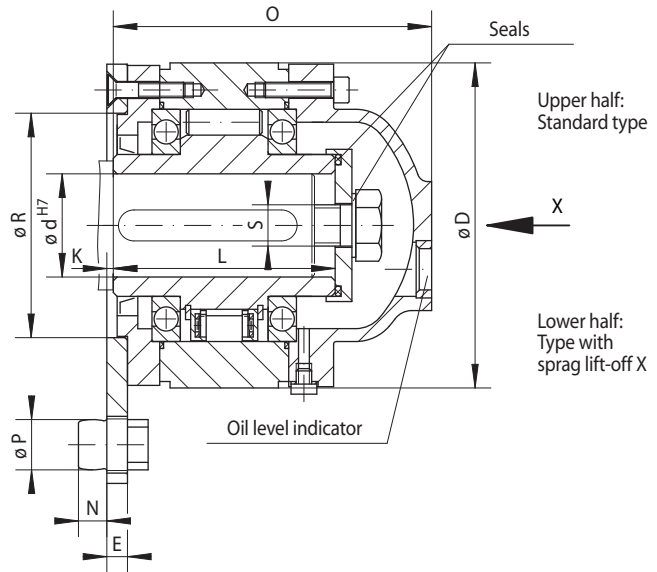

33-2

Backstop	Standard type For universal use	Type with sprag lift-off X For extended service life using sprag lift-off at high speed rotating inner ring	Dimensions																		

Freewheel Size	Type	Nominal Torque M_N Nm	Max. speed Inner ring freewheels min^{-1}	Type	Nominal Torque M_N Nm	Sprag lift-off at inner ring speed min^{-1}	Max. speed Inner ring freewheels min^{-1}	Bore d		A	C	D	E	H	K	L	N	O	P	Q	R	S for Screw	Weight kg
								Standard mm	max. mm														
BA 12	R	150	1 750					15	15	71	50	71	8	53	4,5	68	9	91	11,5	42	45	M 6	2
BA 15	R	230	1 650					20	20	81	60	81	8	62	4,5	70	9	93	13,5	50	50	M 6	3
BA 18	R	340	1 550					25	25	96	70	96	8	73	4,5	70	9	96	15,5	60	60	M 10	4
BA 20	R	420	1 450	DX	400	750	1 700	30	30	110	90	106	8	80	2,5	77	11	104	19,5	65	70	M 10	5
BA 25	R	800	1 250	DX	650	700	1 600	40	40	126	100	126	8	90	2,5	93	11	125	19,5	75	80	M 12	8
BA 28	R	1 200	1 100					45	45	140	110	136	10	105	3,5	95	14	129	24,5	85	90	M 12	9
BA 30	R	1 600	1 000	DX	1 100	630	1 600	50	50	155	120	151	10	120	3,5	102	16	140	27,5	95	100	M 16	12
BA 35	R	1 800	900					55	55	170	130	161	10	140	3,5	110	19	151	33,5	112	110	M 16	15
BA 40	R	3 500	800	SX	1 400	430	1 500	60	60	190	150	181	12	160	5,5	116	22	160	37,5	130	120	M 16	20
BA 45	R	7 100	750	SX	2 300	400	1 500	70	70	210	160	196	14	175	7,0	130	26	176	41,5	140	130	M 16	25
BA 50	R	7 500	700					75	75	220	180	206	14	185	7,0	132	26	178	41,5	150	140	M 16	30
BA 52	R	9 300	650	SX	4 900	320	1 500	80	80	230	190	216	14	200	4,5	150	26	208	41,5	160	150	M 20	35
BA 55	R	12 500	550	SX	6 500	320	1 250	90	90	255	200	246	15	210	3,5	170	29	228	49,5	170	160	M 20	50
BA 60	R	14 500	500	SX	14 500	250	1 100	100	105	295	220	291	20	250	8,5	206	35	273	60,0	200	190	M 24	91
BA 70	R	22 500	425	SX	21 000	240	1 000	120	120	335	260	321	25	280	14,0	215	39	291	65,0	225	210	M 24	115
BA 80	R	25 000	375					130	130	360	280	351	30	280	18,5	224	39	302	65,0	225	220	M 24	150
BA 90	R	33 500	350					140	140	385	300	371	35	310	22,5	236	55	314	70,0	250	240	M 30	180
BA 95	R	35 000	300					150	150	400	350	391	40	310	27,5	249	55	337	70,0	250	250	M 30	225
BA 100	R	57 500	250	UX	42 500	210	750	150	150	420	380	411	45	345	31,5	276	60	372	80,0	280	270	M 30	260

Freewheels with bore diameters highlighted blue in the table are available with short delivery times.
The maximum transmissible torque is 2 times the specified nominal torque. See page 14 for determination of selection torque.
Keyway according to DIN 6885, page 1 • Tolerance of keyway width JS10.

Mounting

The backdriving torque is supported by the lever arm with holding pin. The holding pin engages in a slot or bore in the frame of the machine. It must have 0,5 to 2 mm play in the axial and radial directions.

If the holding pin is removed, the shaft can be turned in both directions.

The tolerance of the shaft must be ISO h6 or j6. For freewheels BA, the inner ring must be secured axially with the supplied retainer plate. Prior to commissioning, the freewheel must be filled with oil of the specified quality.

Example for ordering

Freewheel size BA 30, type with sprag lift-off X and 50 mm bore:

- BA 30 DX, d = 50 mm

When ordering, please also specify the freewheeling direction of the inner ring when viewed in direction X:

- counterclockwise free or
- clockwise free

Morskate®



Any questions? Please contact us.

Morskate Aandrijvingen BV

Oosterveldsingel 47A
7558 PJ Hengelo (Ov)
The Netherlands

NL

T +31 (0)74 - 760 11 11
info@morskateaandrijvingen.nl
www.morskateaandrijvingen.nl

DE

T +49 692 - 222 34 95
info@morskateantriebstechnik.de
www.morskateantriebstechnik.de

EN

T +31 (0)74 - 760 11 11
info@morskatedrivetechnology.com
www.morskatedrivetechnology.com