

# Complete Freewheels FB

for bolting to the face  
with sprags, available in four types

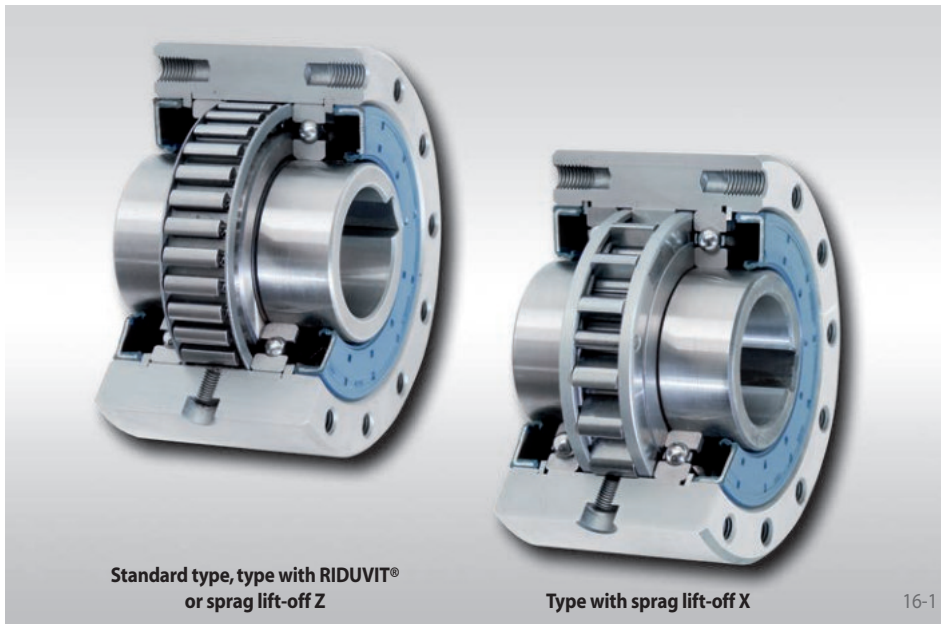

Standard type, type with RIDUVIT®  
or sprag lift-off Z

Type with sprag lift-off X

16-1

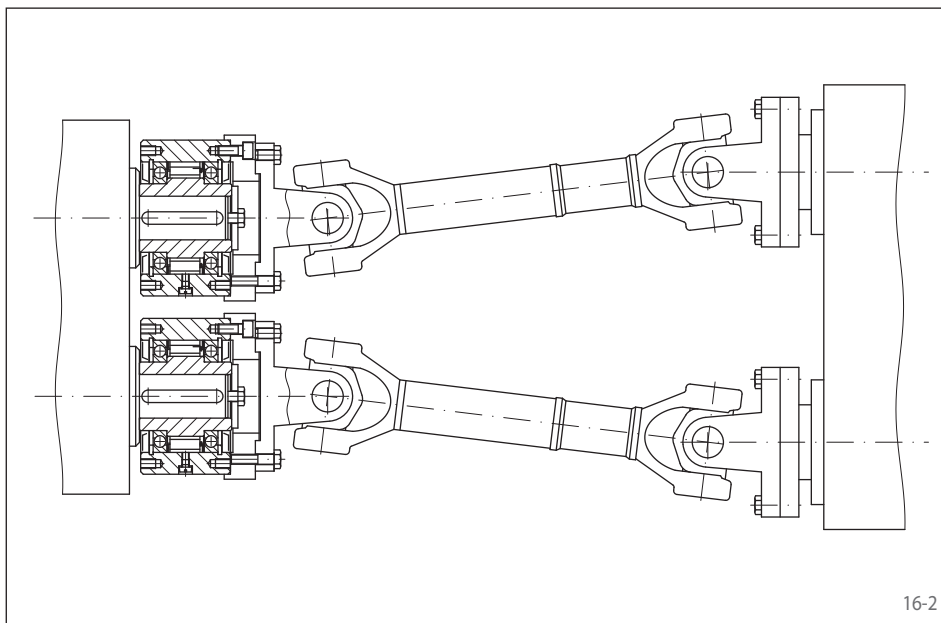

16-2

## Application as

- ▶ Backstop
- ▶ Overrunning Clutch
- ▶ Indexing Freewheel

## Features

Complete Freewheels FB are sealed sprag freewheels with ball bearings. They are supplied oil-filled and ready for installation.

In addition to the standard type, three other types are available for extended service life.

Nominal torques up to 160 000 Nm.

Bores up to 300 mm. A multitude of standardized bore diameters are available with short delivery times.

## Application example

Two Complete Freewheels FB 82 SFT as overrunning clutches in the drive of an edge trimming shear in a wide strip roll train. When trimming the edges of the strip, the trimming rollers are driven by the drive of the edge trimming shear. By doing so, the two freewheels work in driving operation. As soon as the sheet metal strip is gripped by the next pair of rollers, they pull the strip at an increased speed and the inner rings overrun the slower turning drive of the edge trimming shear. By doing so, the freewheels work in freewheeling operation. The RIDUVIT® sprags give the freewheels an extended service life.

## Mounting

The customer attachment part is on the external diameter D and then bolted on to the face.

The tolerance of the shaft must be ISO h6 or j6 and the tolerance of the pilot diameter D of the attachment part must be ISO H7 or J7.

## Example for ordering

Freewheel size FB 72, type with sprag lift-off Z and 40 mm bore:

- FB 72 LZ, d = 40 mm

When ordering freewheel size FB 340 and FB 440, please also specify the freewheeling direction of the inner ring when viewed in direction X:

- counterclockwise free or
- clockwise free

# Complete Freewheels FB

for bolting to the face  
with sprags, available in four types

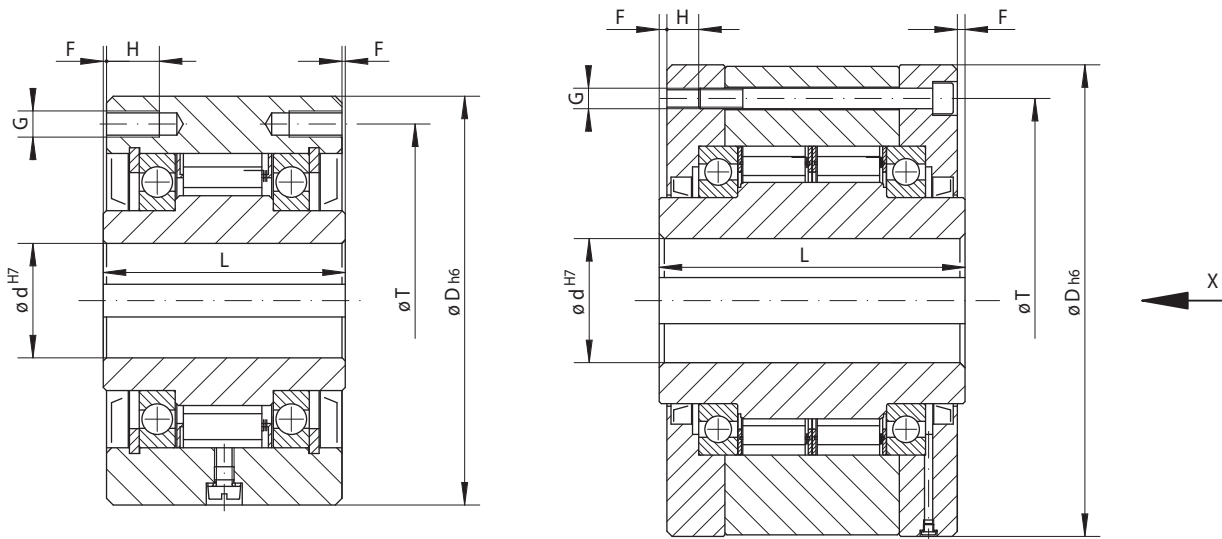

Size FB 24 to FB 270

17-1

Size FB 340 to FB 440

17-2

Indexing Freewheel Overrunning Clutch Backstop	<b>Standard type</b> For universal use	<b>Type with RIDUVIT®</b> For extended service life using coated sprags	<b>Type with sprag lift-off X</b> For extended service life using sprag lift-off at high speed rotating inner ring	<b>Type with sprag lift-off Z</b> For extended service life using sprag lift-off at high speed rotating outer ring

Freewheel Size	Type	Nominal torque $M_N$ Nm	Max. speed		Type	Nominal torque $M_N$ Nm	Max. speed		Type	Nominal torque $M_N$ Nm	Sprag lift-off at inner ring speed $\text{min}^{-1}$	Max. speed		Type	Nominal torque $M_N$ Nm	Sprag lift-off at outer ring speed $\text{min}^{-1}$	Max. speed	
			Inner ring freewheels/overruns $\text{min}^{-1}$	Outer ring freewheels/overruns $\text{min}^{-1}$			Inner ring freewheels/overruns $\text{min}^{-1}$	Outer ring freewheels/overruns $\text{min}^{-1}$				Inner ring freewheels/overruns $\text{min}^{-1}$	Outer ring drives $\text{min}^{-1}$				Outer ring freewheels/overruns $\text{min}^{-1}$	Inner ring drives $\text{min}^{-1}$
FB 24	CF	45	4 800	5 500	CFT	45	4 800	5 500										
FB 29	CF	80	3 500	4 000	CFT	80	3 500	4 000										
FB 37	SF	200	2 500	2 600	SFT	200	2 500	2 600										
FB 44	SF	320	1 900	2 200	SFT	320	1 900	2 200	DX	130	860	1 900	344	CZ	110	850	3 000	340
FB 57	SF	630	1 400	1 750	SFT	630	1 400	1 750	DX	460	750	1 400	300	LZ	430	1 400	2 100	560
FB 72	SF	1 250	1 120	1 600	SFT	1 250	1 120	1 600	DX	720	700	1 150	280	LZ	760	1 220	1 800	488
FB 82	SF	1 800	1 025	1 450	SFT	1 800	1 025	1 450	DX	1 000	670	1 050	268	SFZ	1 700	1 450	1 600	580
FB 107	SF	2 500	880	1 250	SFT	2 500	880	1 250	DX	1 500	610	900	244	SFZ	2 500	1 300	1 350	520
FB 127	SF	5 000	800	1 150	SFT	5 000	800	1 150	SX	3 400	380	800	152	SFZ	5 000	1 200	1 200	480
FB 140	SF	10 000	750	1 100	SFT	10 000	750	1 100	SX	7 500	320	750	128	SFZ	10 000	950	1 150	380
FB 200	SF	20 000	630	900	SFT	20 000	630	900	SX	23 000	240	630	96	SFZ	20 000	680	900	272
FB 270	SF	40 000	510	750	SFT	40 000	510	750	UX	40 000	210	510	84	SFZ	37 500	600	750	240
FB 340	SF	80 000	460	630	SFT	80 000	460	630										
FB 440	SF	160 000	400	550	SFT	160 000	400	550										

The maximum transmissible torque is 2 times the specified nominal torque. See page 14 for determination of selection torque.

Freewheel Size	Bore d		D	F	G**	H	L	T	Z**	Weight
	Standard mm	max. mm								
FB 24	12	14*	62	1,0	M 5	8	50	51	3	0,9
FB 29	15	17*	68	1,0	M 5	8	52	56	3	1,1
FB 37	20	22*	75	0,5	M 6	10	48	65	4	1,3
FB 44	25*	25*	90	0,5	M 6	10	50	75	6	1,9
FB 57	30	32*	100	0,5	M 8	12	65	88	6	2,8
FB 72	40	42*	125	1,0	M 8	12	74	108	12	5,0
FB 82	50*	50*	135	2,0	M 10	16	75	115	12	5,8
FB 107	60	65*	170	2,5	M 10	16	90	150	10	11,0
FB 127	70	75*	200	3,0	M 12	18	112	180	12	19,0
FB 140	90	95*	250	5,0	M 16	25	150	225	12	42,0
FB 200	120	120	300	5,0	M 16	25	160	270	16	62,0
FB 270	140	150	400	6,0	M 20	30	212	360	18	150,0
FB 340	180	240	500	7,5	M 20	35	265	450	24	275,0
FB 440	220	300	630	7,5	M 30	40	315	560	24	510,0

Freewheels with bore diameters highlighted blue in the table are available with short delivery times.

Keyway according to DIN 6885, page 1 • Tolerance of keyway width JS10.

\* Keyway according to DIN 6885, page 3 • Tolerance of keyway width JS10.

\*\* Z = Number of tapped holes G on pitch circle T.

**Morskate®**



Any questions? Please contact us.

**Morskate Aandrijvingen BV**

Oosterveldsingel 47A  
7558 PJ Hengelo (Ov)  
The Netherlands

NL

T +31 (0)74 - 760 11 11  
info@morskateaandrijvingen.nl  
www.morskateaandrijvingen.nl

DE

T +49 692 - 222 34 95  
info@morskateantriebstechnik.de  
www.morskateantriebstechnik.de

EN

T +31 (0)74 - 760 11 11  
info@morskatedrivetechnology.com  
www.morskatedrivetechnology.com