

ROTEX® BTAN and SBAN Flexible jaw couplings

With brake drum/with brake disk

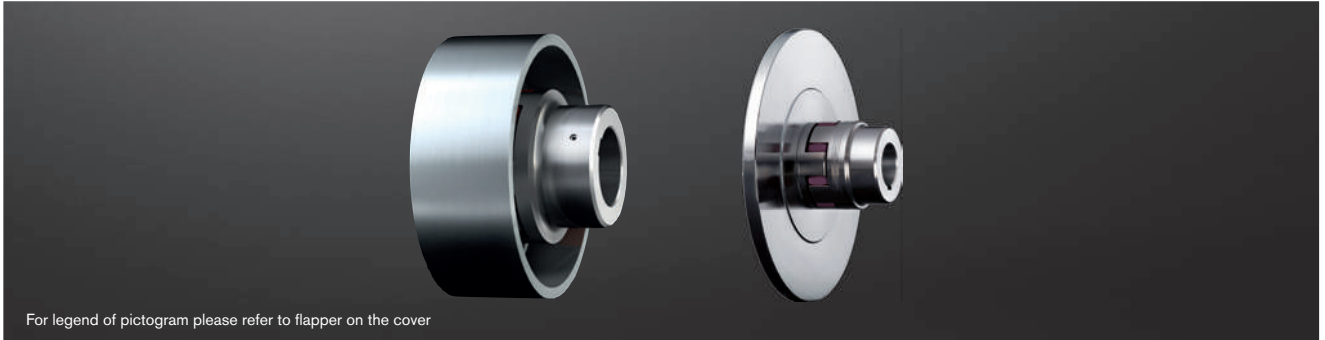

For legend of pictogram please refer to flapper on the cover



ROTEX® Type BTAN and SBAN

Size	Pilot bore, d, D, D ₁	Max. finish bore d ₁		Dimensions [mm]											
		GJS	Steel	D _H	D ₂	D ₄	d _H	z	pitch ¹⁾	M	T _A [Nm]	l ₁ , l ₂	E	L	
38	See jaw couplings on page 34 to 36 For stock programme / basic programme see page 32 and 33	—	35	80	50	66	38	8	8 x 45°	M8	35	45	24	114	
42		—	45	95	60	80	46	12	16 x 22.5°	M8	41	50	26	126	
48		—	50	105	68	90	51	12		M8	41	56	28	140	
55		—	58	120	78	102	60	8	8 x 45°	M10	83	65	30	160	
65		—	68	135	92	116	68	12	16 x 22.5°	M10	83	75	35	185	
75		—	78	160	106	136	80	15	20 x 18°	M12	120	85	40	210	
90		—	100	200	140	172	100	15		M16	295	100	45	245	
100		100	—	225	156	195	113	15	M16	295	110	50	270		
110		110	—	255	176	218	127	15	M20	580	120	55	295		
125		130	—	290	204	252	147	15	M20	580	140	60	340		

Brake drum	Type BTAN										Speed rpm [V] (30 m/s)	Brake disk	Type SBAN										Speed rpm [V] (30 m/s)
	ROTEX® BTAN dimension „C“												ROTEX® dimension „N“										
	38	42	48	55	65	75	90	100	110	125		38	42	48	55	65	75	90	100	110	125		
160x60	14										3550	200x12.5	31.25										2800
200x75	9	12	17	24							2800	250x12.5	31.25	34.25	39.25								2240
250x95	1	4	9	16	25	33					2240	315x16		32.5	37.5	44.5	53.5	61.5					1800
315x118		-5	0	7	16	24	36				1800	400x16			37.5	44.5	53.5	61.5	73.5	81.5	88.5		1400
400x150		-18	-13	-6	3	11	23	31	38		1400	500x16				44.5	53.5	61.5	73.5	81.5	88.5	104.5	1120
500x190						-12	-4	8	16	23	39	1120	630x20				51.5	59.5	71.5	79.5	86.5	102.5	900
630x236							-22	-10	-2	5	21	900	710x20				51.5	59.5	71.5	79.5	86.5	102.5	800
710x265									-13	-6	10	800	800x25						69	77	84	100	710
800x300										-4	710	900x25									84	100	630

¹⁾ Thread in the hub between the cams.

Other sizes on request according to dimension sheet:

BTAN: M380821

SBAN straight: M380822; cranked: M 370065

FNN hub: M 380823

Finish bore according to ISO fit H7, feather keyway according to DIN 6885, sheet 1 [JS9].

Ordering example:	ROTEX® 38	BTAN	Ø200x75	98 ShA	1Nd	Ø34	1	Ø30
	Coupling size	Type	Brake drum Ø x width	Spider hardness	Component	Finish bore	Component	Finish bore

Any questions? Please contact us.

Morskate Aandrijvingen BV

Oosterveldsingel 47A
7558 PJ Hengelo (Ov)
The Netherlands

NL

T +31 (0)74 - 760 11 11
info@morskateaandrijvingen.nl
www.morskateaandrijvingen.nl

DE

T +49 692 - 222 34 95
info@morskateantriebstechnik.de
www.morskateantriebstechnik.de

EN

T +31 (0)74 - 760 11 11
info@morskatedrivetechnology.com
www.morskatedrivetechnology.com

Components

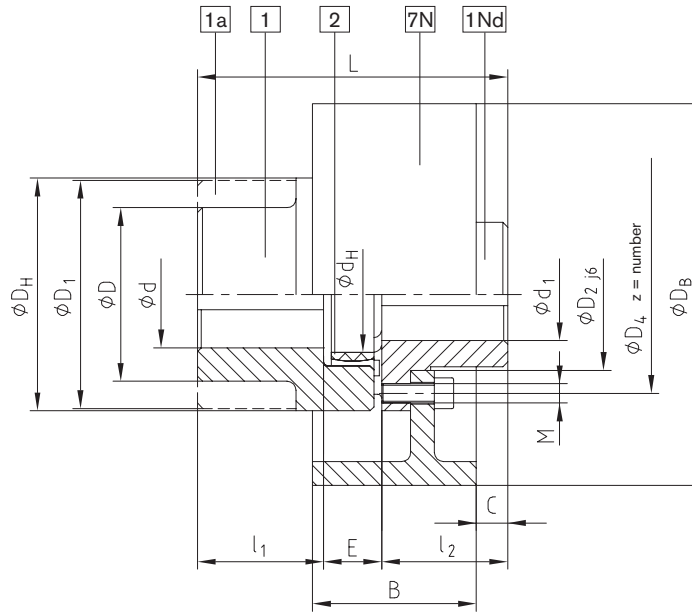

Brake drum
Type BTAN

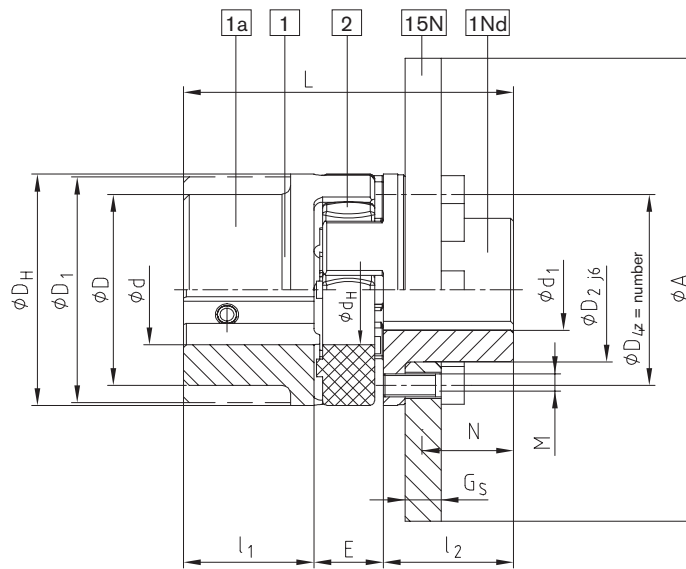

Brake disk
Type SBAN

ROTEX®

POLY-NORM®

POLY

REVOLEX®

Legend of pictograms



Torsionally rigid



Light-weight



Protected against corrosion



Torsionally flexible

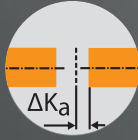

Axial compensation



Electrically insulating



Highly flexible

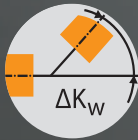

Angular compensation



Maximum speed



Damping vibrations

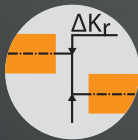

Radial compensation



No eddy current losses



Axial plug-in



Shiftable at standstill



Torque limiter slipping



Consider shaft distance



Double-cardanic



Torque limiter with synchronous ratcheting



Relatively short shaft distance



Radial disassembly
Ease of service



Torque limiter with idle rotation type

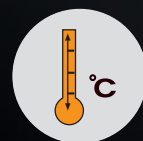

Maximum operating temperature



Standard drop-out center lengths available



Hardened surface



High speeds



Available in accordance with API



Accuracy X %



Backlash-free



Complying with ATEX
For details refer to our ATEX leaflet



Consider axial displacement



Shear type, separating, slipping



Maintenance-free



Additional features compared to standard version

Displacements

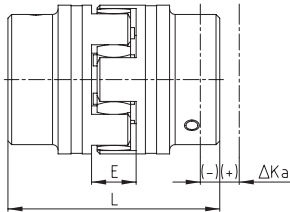
Axial displacement ΔK_a

$$L_{\max.} = L + \Delta K_a$$

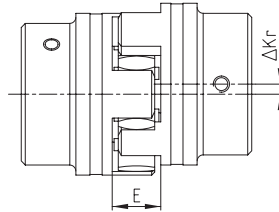
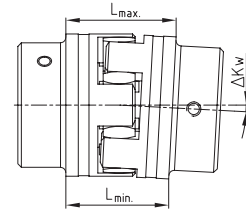
Radial displacement ΔK_r

Angular displacement ΔK_w [degree]

$$\Delta K_w \text{ [mm]} = L_{\max} - L_{\min}$$

Displacements for spider 92 and 98 Shore A

ROTEX® size	14	19	24	28	38	42	48	55	65	90	100	110	125	140	160	180	
Max. axial displacement ΔK_a [mm]	-0.5 +1.0	-0.5 +1.2	-0.5 +1.4	-0.7 +1.5	-0.7 +1.8	-1.0 +2.0	-1.0 +2.1	-1.0 +2.2	-1.0 +2.6	-1.5 +3.0	-1.5 +3.4	-1.5 +3.8	-2.0 +4.2	-2.0 +4.6	-2.0 +5.0	-2.5 +5.7	-3.0 +6.4
Max. radial displacement with $n=1500$ rpm ΔK_r [mm]	0.17	0.20	0.22	0.25	0.28	0.32	0.36	0.38	0.42	0.48	0.50	0.52	0.55	0.60	0.62	0.64	0.68
Max. angular displacement with $n=1500$ rpm ΔK_w [degree]	1.2	1.2	0.9	0.9	1.0	1.0	1.1	1.1	1.2	1.2	1.2	1.2	1.3	1.3	1.2	1.2	1.2
ΔK_w [mm]	0.67	0.82	0.85	1.05	1.35	1.70	2.00	2.30	2.70	3.30	4.30	4.80	5.60	6.50	6.60	7.60	9.00

Displacements of spider 64 Shore D

ROTEX® size	14	19	24	28	38	42	48	55	65	75	90	100	110	125	140	160	180
Max. axial displacement ΔK_a [mm]	-0.5 +1.0	-0.5 +1.2	-0.5 +1.4	-0.7 +1.5	-0.7 +1.8	-1.0 +2.0	-1.0 +2.1	-1.0 +2.2	-1.0 +2.6	-1.5 +3.0	-1.5 +3.4	-1.5 +3.8	-2.0 +4.2	-2.0 +4.6	-2.0 +5.0	-2.5 +5.7	-3.0 +6.4
Max. radial displacement with $n=1500$ rpm ΔK_r [mm]	0.11	0.13	0.15	0.18	0.21	0.23	0.25	0.27	0.30	0.34	0.36	0.37	0.40	0.43	0.45	0.46	0.49
Max. angular displacement with $n=1500$ rpm ΔK_w [degree]	1.1	1.1	0.8	0.8	0.9	0.9	1.0	1.0	1.1	1.1	1.1	1.1	1.2	1.2	1.1	1.1	1.1
ΔK_w [mm]	0.57	0.76	0.76	0.90	1.25	1.40	1.80	2.00	2.50	3.00	3.80	4.30	5.30	6.00	6.10	7.10	8.00

Displacements for spider PA, PEEK

ROTEX® size	14	19	24	28	38	42	48	55	65	75	90	100	110	125	140
Max. axial displacement ΔK_a [mm]	-0.5 +1.0	-0.5 +1.2	-0.5 +1.4	-0.7 +1.5	-0.7 +1.8	-1.0 +2.0	-1.0 +2.1	-1.0 +2.2	-1.0 +2.6	-1.5 +3.0	-1.5 +3.4	-1.5 +3.8	-2.0 +4.2	-2.0 +4.6	-2.0 +5.0
Max. radial displacement with $n=1500$ rpm ΔK_r [mm]	0.08	0.10	0.11	0.12	0.14	0.16	0.18	0.19	0.21	0.24	0.25	0.26	0.27	0.30	0.31
Max. angular displacement with $n=1500$ rpm ΔK_w [degree]	0.60	0.45	0.45	0.50	0.50	0.55	0.55	0.55	0.60	0.60	0.60	0.60	0.65	0.65	0.60
ΔK_w [mm]	0.33	0.41	0.42	0.52	0.67	0.85	1.00	1.15	1.35	1.65	2.15	2.40	2.80	3.25	3.30

The above-mentioned displacement figures of the flexible ROTEX® couplings are standard values taking into account the load of the coupling up to the rated torque T_{KN} and an operating speed $n = 1500$ rpm along with an ambient temperature of $+30^\circ\text{C}$.

The displacement figures may only be used one by one - if they appear simultaneously, they must be limited in proportion. Care should be taken to maintain the distance dimension E accurately in order to allow for axial clearance of the coupling while in operation. Detailed mounting instructions are shown on our homepage www.ktr.com.

ROTEX®

Flexible jaw couplings

Properties of standard spiders

ROTEX® 14



ROTEX® 19

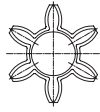

ROTEX® 24 - 65

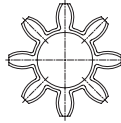

ROTEX® 75 - 160

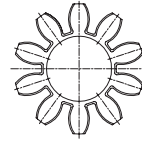



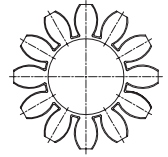

ROTEX® 180



Degree of hardness



Spider type (Shore hardness)	92 Shore A (T-PUR®)	92 Shore A
	 T-PUR®	
Size	14 to 180	14 to 90
Material	T-PUR®	Polyurethane (PUR)
Permissible temperature range		
Permanent temperature	-50 °C to +120 °C	-40 °C to +90 °C
Short-term temperature	-50 °C to +150 °C	-50 °C to +120 °C
Features	<ul style="list-style-type: none"> - significantly higher service life expectancy - very good temperature resistance - improved damping of vibrations - good damping, average flexibility - suitable for all hub materials 	<ul style="list-style-type: none"> - good damping, average flexibility - suitable for all hub materials

Spider type (Shore hardness)	98 Shore A (T-PUR®) ¹⁾	98 Shore A ¹⁾
	 T-PUR®	
Size	14 to 180	14 to 90
Material	T-PUR®	Polyurethane (PUR)
Permissible temperature range		
Permanent temperature	-50 °C to +120 °C	-30 °C to +90 °C
Short-term temperature	-50 °C to +150 °C	-40 °C to +120 °C
Features	<ul style="list-style-type: none"> - significantly higher service life expectancy - very good temperature resistance - improved damping of vibrations - transmission of high torques with average damping - recommended hub material: steel, GJL and GJS 	<ul style="list-style-type: none"> - transmission of high torques with average damping - recommended hub material: steel, GJL and GJS

Spider type (Shore hardness)	64 Shore D (T-PUR®)
	 T-PUR®
Size	14 to 180
Material	T-PUR®
Permissible temperature range	
Permanent temperature	-50 °C to +120 °C
Short-term temperature	-50 °C to +150 °C
Features	<ul style="list-style-type: none"> - significantly higher service life expectancy - very good temperature resistance - improved damping of vibrations - transmission of very high torques with low damping - recommended hub material: steel and GJS

Technical data of standard spiders

92 Shore A spider made of T-PUR® and PUR															
ROTEX® size	Max. speed		Torsion angle ϕ with		Torque [Nm]				Damping power P _{KW} [W] ³⁾	Relative damping ψ	Resonance factor V _R	Torsion spring stiffness C dyn. [Nm/rad]			
	v=35 m/s cast material	v=40 m/s steel	T _{KN}	T _{K max}	DIN 740 ¹⁾			T _{K max} ²⁾				1.0 T _{KN}	0.75 T _{KN}	0.5 T _{KN}	0.25 T _{KN}
			Rated T _{KN}	Max. T _{K max}	Vibratory T _{KW}										
14	22200	25400	6.4°	10°	7.5	15	2.0	22.5	—			0.38x10 ³	0.31x10 ³	0.24x10 ³	0.14x10 ³
19	16700	19000			10	20	2.6	30	4.8			1.28x10 ³	1.05x10 ³	0.8x10 ³	0.47x10 ³
24	12100	13800			35	70	9.1	105	6.6			4.86x10 ³	3.98x10 ³	3.01x10 ³	1.79x10 ³
28	10100	11500			95	190	25	285	8.4			10.9x10 ³	8.94x10 ³	6.76x10 ³	4.01x10 ³
38	8300	9500			190	380	49	570	10.2			21.05x10 ³	17.26x10 ³	13.05x10 ³	7.74x10 ³
42	7000	8000			265	530	69	795	12.0			23.74x10 ³	19.47x10 ³	14.72x10 ³	8.73x10 ³
48	6350	7250			310	620	81	930	13.8			36.7x10 ³	30.09x10 ³	22.75x10 ³	13.49x10 ³
55	5550	6350			410	820	107	1230	15.6			50.7x10 ³	41.59x10 ³	31.45x10 ³	18.64x10 ³
65	4950	5650	3.2°	5°	625	1250	163	1875	18.0	0.80	7.90	97.1x10 ³	79.65x10 ³	60.2x10 ³	35.7x10 ³
75	4150	4750			1280	2560	333	3840	21.6			113.3x10 ³	92.9x10 ³	70.3x10 ³	41.65x10 ³
90	3300	3800			2400	4800	624	7200	30.0			190.1x10 ³	155.9x10 ³	117.9x10 ³	69.9x10 ³
100	2950	3350			3300	6600	858	9900	36.0			253.1x10 ³	207.5x10 ³	156.9x10 ³	93x10 ³
110	2600	2950			4800	9600	1248	14400	42.0			415.5x10 ³	336.9x10 ³	257.6x10 ³	177.4x10 ³
125	2300	2600			6650	13300	1729	19950	48.0			647.7x10 ³	537.3x10 ³	412.2x10 ³	277.5x10 ³
140	2050	2350			8550	17100	2223	25650	54.6			813.4x10 ³	670.2x10 ³	519.7x10 ³	351.7x10 ³
160	1800	2050			12800	25600	3328	38400	75.0			1298x10 ³	1104x10 ³	901.9x10 ³	655.7x10 ³
180	1550	1800			18650	37300	4849	55950	78.0			2327x10 ³	1981x10 ³	1618x10 ³	1176x10 ³

98 Shore A spider made of T-PUR® and PUR															
ROTEX® size	Max. speed		Torsion angle ϕ with		Torque [Nm]				Damping power P _{KW} [W] ³⁾	Relative damping ψ	Resonance factor V _R	Torsion spring stiffness C dyn. [Nm/rad]			
	v=35 m/s cast material	v=40 m/s steel	T _{KN}	T _{K max}	DIN 740 ¹⁾			T _{K max} ²⁾				1.0 T _{KN}	0.75 T _{KN}	0.5 T _{KN}	0.25 T _{KN}
			Rated T _{KN}	Max. T _{K max}	Vibratory T _{KW}										
14	22200	25400	6.4°	10°	12.5	25	3.3	37.5	—			0.56x10 ³	0.46x10 ³	0.35x10 ³	0.21x10 ³
19	16700	19000			17	34	4.4	51	4.8			2.92x10 ³	2.39x10 ³	1.81x10 ³	1.07x10 ³
24	12100	13800			60	120	16	180	6.6			9.93x10 ³	8.14x10 ³	6.16x10 ³	3.65x10 ³
28	10100	11500			160	320	42	480	8.4			26.77x10 ³	21.95x10 ³	16.6x10 ³	9.84x10 ³
38	8300	9500			325	650	85	975	10.2			48.57x10 ³	39.83x10 ³	30.11x10 ³	17.85x10 ³
42	7000	8000			450	900	117	1350	12.0			54.5x10 ³	44.69x10 ³	33.79x10 ³	20.03x10 ³
48	6350	7250			525	1050	137	1575	13.8			65.3x10 ³	53.54x10 ³	40.48x10 ³	24x10 ³
55	5550	6350			685	1370	178	2055	15.6			95x10 ³	77.9x10 ³	58.88x10 ³	34.9x10 ³
65	4950	5650	3.2°	5°	940	1880	244	2820	18.0	0.80	7.90	129.5x10 ³	106.2x10 ³	80.3x10 ³	47.6x10 ³
75	4150	4750			1920	3840	499	5760	21.6			197.5x10 ³	162x10 ³	122.5x10 ³	72.6x10 ³
90	3300	3800			3600	7200	936	10800	30.0			312.2x10 ³	256x10 ³	193.6x10 ³	114.7x10 ³
100	2950	3350			4950	9900	1287	14850	36.0			383.3x10 ³	314.3x10 ³	237.6x10 ³	140.9x10 ³
110	2600	2950			7200	14400	1872	21600	42.0			805.9x10 ³	663.1x10 ³	515.3x10 ³	360.5x10 ³
125	2300	2600			10000	20000	2600	30000	48.0			1207x10 ³	1003x10 ³	773.1x10 ³	552.5x10 ³
140	2050	2350			12800	25600	3328	38400	54.6			1549x10 ³	1283x10 ³	979.8x10 ³	674.1x10 ³
160	1800	2050			19200	38400	4992	57600	75.0			2481x10 ³	2137x10 ³	1781x10 ³	1275x10 ³
180	1550	1800			28000	56000	7280	84000	78.0			4220x10 ³	3635x10 ³	3031x10 ³	2170x10 ³

64 Shore D spider made of T-PUR® and PUR															
ROTEX® size	Max. speed		Torsion angle ϕ with		Torque [Nm]				Damping power P _{KW} [W] ³⁾	Relative damping ψ	Resonance factor V _R	Torsion spring stiffness C dyn. [Nm/rad]			
	v=35 m/s cast material	v=40 m/s steel	T _{KN}	T _{K max}	DIN 740 ¹⁾			T _{K max} ²⁾				1.0 T _{KN}	0.75 T _{KN}	0.5 T _{KN}	0.25 T _{KN}
			Rated T _{KN}	Max. T _{K max}	Vibratory T _{KW}										
14	22200	25400	4.5°	7.0°	16	32	4.2	48	9.0			0.76x10 ³	0.62x10 ³	0.47x10 ³	0.28x10 ³
19	16700	19000			21	42	5.5	63	7.2			5.35x10 ³	4.39x10 ³	3.32x10 ³	1.97x10 ³
24	12100	13800			75	150	19.5	225	9.9			15.11x10 ³	12.39x10 ³	9.37x10 ³	5.55x10 ³
28	10100	11500			200	400	52	600	12.6			27.52x10 ³	22.57x10 ³	17.06x10 ³	10.12x10 ³
38	8300	9500			405	810	105	1215	15.3			70.15x10 ³	57.52x10 ³	43.49x10 ³	25.78x10 ³
42	7000	8000			560	1120	146	1680	18.0			79.9x10 ³	65.5x10 ³	49.52x10 ³	29.35x10 ³
48	6350	7250			655	1310	170	1965	20.7			95.5x10 ³	78.3x10 ³	59.22x10 ³	35.1x10 ³
55	5550	6350			825	1650	215	2475	23.4			107.9x10 ³	88.5x10 ³	66.9x10 ³	39.66x10 ³
65	4950	5650	2.5°	3.6°	1175	2350	306	3525	27.0	0.75	8.50	151.1x10 ³	123.9x10 ³	93.7x10 ³	55.53x10 ³
75	4150	4750			2400	4800	624	7200	32.4			248.2x10 ³	203.5x10 ³	153.9x10 ³	91.2x10 ³
90	3300	3800			4500	9000	1170	13500	45.0			674.5x10 ³	553.1x10 ³	418.2x10 ³	247.9x10 ³
100	2950	3350			6185	12370	1608	18555	54.0			861.2x10 ³	706.2x10 ³	533.9x10 ³	316.5x10 ³
110	2600	2950			9000	18000	2340	27000	63.0			1230x10 ³	1001x10 ³	773.1x10 ³	531.4x10 ³
125	2300	2600			12500	25000	3250	37500	72.0			1749x10 ³	1436x10 ³	1149x10 ³	832.1x10 ³
140	2050	2350			16000	32000	4160	48000	81.9			2312x10 ³	1929x10 ³	1521x10 ³	1082x10 ³
160	1800	2050			24000	48000	6240	72000	112.5			3415x10 ³	2961x10 ³	2471x10 ³	1830x10 ³
180	1550	1800			35000	70000	9100	105000	117.0			5670x10 ³	4917x10 ³	4103x10 ³	3038x10 ³

¹⁾ see catalogue page 15
²⁾ ≤ 1000 load cycles
³⁾ with +30°C



Temperature factor S _t											
	-50 °C	-30 °C +30 °C	+40 °C	+50 °C	+60 °C	+70 °C	+80 °C	+90 °C	+100 °C	+110 °C	+120 °C
T-PUR®	1.0	1.0	1.1	1.2	1.3	1.45	1.6	1.8	2.1	2.5	3.0
PUR	—	1.0	1.2	1.3	1.4	1.55	1.8	2.2	—	—	—

Unless explicitly specified in your order, we will supply spiders with Shore hardness 92 Shore A T-PUR®.
For circumferential speeds exceeding v = 30 m/s dynamic balancing is required. For circumferential speeds exceeding v = 35 m/s only steel or nodular iron.

ROTEX®

Flexible jaw couplings

Technical data and properties of special spiders

		
Designation	PA	PEEK
Material	Polyamide	Polyetheretherketone
Permissible temperature range		
Permanent temperature	-20 °C to +130 °C ¹⁾	up to +180 °C (ATEX up to +160 °C)
Short-term temperature	-30 °C to +150 °C ¹⁾	up to +250 °C
Features	<ul style="list-style-type: none"> - small twisting angle and high torsion spring stiffness - transmission of very high torques with very low damping - good resistance to chemicals ¹⁾ - recommended hub material: steel - high restoring forces with displacements 	<ul style="list-style-type: none"> - small twisting angle and high torsion spring stiffness - transmission of very high torques with very low damping - highly temperature-resistant, resistant to hydrolysis - good resistance to chemicals - recommended hub material: steel - high restoring forces with displacements

¹⁾ different properties depending on compound

Torques			
ROTEX® size	PA, PEEK		
	T _{KN} [Nm]	T _{K max} [Nm]	T _{KW} [Nm]
14	22	44	5.5
19	30	60	8.0
24	105	210	27.5
28	280	560	73
38	565	1130	147
42	785	1570	204
48	915	1830	238
55	1200	2400	312
65	1645	3290	427
75	2560	5130	667
90	6300	12600	1640
100	8650	17300	2250
110	10500	21000	2730
125	13000	26000	3380

Temperature factor S _t												
	-50 °C	-30 °C +30 °C	+40 °C	+50 °C	+60 °C	+70 °C	+80 °C	+90 °C	+100 °C	+110 °C	+120 °C	+180 °C
PA	-	1.0	1.15	1.25	1.4	1.6	1.9	2.3	3.0	-	-	-
PEEK	-	1.0	1.0	1.0	1.0	1.0	1.0	1.0	1.0	1.0	1.0	1.0

Installation of spider

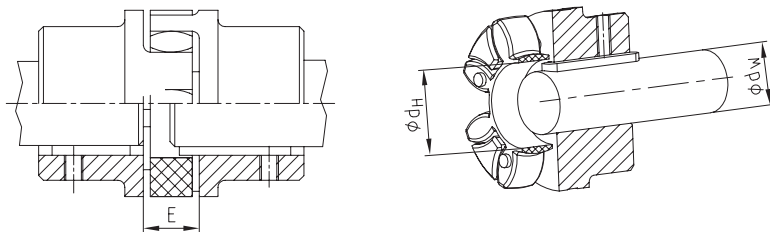

Shaft $\varnothing d_H$ with feather key (acc. to DIN 6885 sheet 1) protruding into the spider $\varnothing d_H$

Assembly dimensions																	
ROTEX® size	14	19	24	28	38	42	48	55	65	75	90	100	110	125	140	160	180
Distance dimension E	13	16	18	20	24	26	28	30	35	40	45	50	55	60	65	75	85
Dimension d _H	10	18	27	30	38	46	51	60	68	80	100	113	127	147	165	190	220
Dimension d _{VV} ²⁾	7	12	20	22	28	36	40	48	55	65	80	95	100	120	135	160	185

²⁾ If the shaft diameter is smaller than or equal to dimension d_H, one shaft end or both shaft ends may protrude with the feather keyway into the spider.

Selection of standard IEC motors

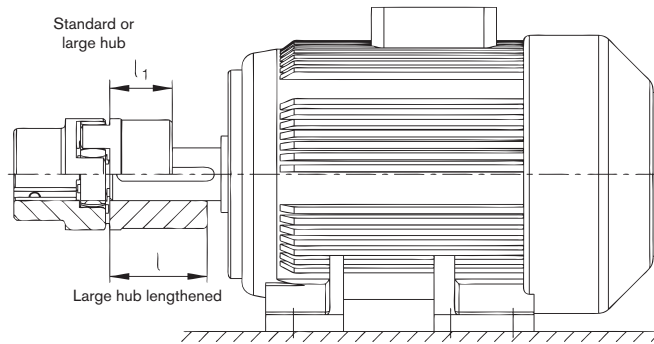

ROTEX® couplings for standard IEC motors, protection class IP 54/IP 55 (spider 92 Shore A)

Size	A. C. motor 50 Hz		Motor power n=3000 rpm 2 poles		ROTEX® coupling size	Motor power n=1500 rpm 4 poles		ROTEX® coupling size	Motor power n=1000 rpm 6 poles		ROTEX® coupling size	Motor power n=750 rpm 8 poles		ROTEX® coupling size
	Shaft end d x l [mm]		Power P [kW]	Torque T [Nm]		Power P [kW]	Torque T [Nm]		Power P [kW]	Torque T [Nm]		Power P [kW]	Torque T [Nm]	
	2 poles	4, 6, 8 poles												
56	9 x 20		0.09	0.32	9 ¹⁾	0.06	0.43	9 ¹⁾	0.037	0.43	9 ¹⁾			
			0.12	0.41		0.09	0.64		0.045	0.52				
63	11 x 23		0.18	0.62	14	0.12	0.88	14	0.06	0.7	14			
			0.25	0.86		0.18	1.3		0.09	1.1				
71	14 x 30		0.37	1.3	14	0.25	1.8	14	0.18	2	14	0.09	1.4	14
			0.55	1.9		0.37	2.5		0.25	2.8		0.12	1.8	
80	19 x 40		0.75	2.5	19	0.55	3.7	19	0.37	3.9	19	0.18	2.5	19
			1.1	3.7		0.75	5.1		0.55	5.8		0.25	3.5	
90S	24 x 50		1.5	5	19	1.1	7.5	19	0.75	8	19	0.37	5.3	19
90L			2.2	7.4		1.5	10		1.1	12		0.55	7.9	
100L	28 x 60		3	9.8	24	2.2	15	24	1.5	15	24	0.75	11	24
112M			4	13		3	20		2.2	22		1.5	21	
132S			5.5	18		4	27		2.2	22		1.5	21	
132M	38 x 80		7.5	25	28	5.5	36	28	3	30	28	2.2	30	28
						7.5	49		4	40		3	40	
									5.5	55				
160M	42 x 110		11	36	38	11	72	38	7.5	75	38	4	54	38
160L			15	49		15	98		11	109		5.5	74	
180M	48 x 110		18.5	60		15	98		11	109		7.5	100	
180L			22	71		18.5	121							
			22	71		22	144		15	148		11	145	
200L	55 x 110		30	97	42	30	196	42	18.5	181	42	15	198	42
			37	120					22	215				
225S						37	240	48				18.5	244	48
225M	55 x 110	60 x 140	45	145		45	292	55	30	293	55	22	290	55
250M	60 x 140	65 x 140	55	177	48	55	356	55	37	361	65 ²⁾	30	392	65
280S			75	241		75	484	65 ²⁾	45	438	65 ²⁾	37	483	65 ²⁾
280M	75 x 140		90	289	55	90	581	55	55	535		45	587	75
315S			110	353		110	707	75	75	727	75	55	712	75
315M			132	423	65	132	849		90	873		75	971	
	65 x 140	80 x 170	160	513		160	1030		110	1070		90	1170	
315L			200	641		200	1290	90	132	1280	90	110	1420	90
					75				160	1550		132	1710	
315	85 x 170		250	802		250	1600		200	1930		160	2070	
			315	1010		315	2020		250	2410	100	200	2580	100
			355	1140		355	2280	100						
355	75 x 140	95 x 170	400	1280	90	400	2570		315	3040	110	250	3220	110
			500	1600		500	3210	110	400	3850		315	4060	125
			560	1790		560	3580		450	4330	125	355	4570	
400	80 x 170	110 x 210	630	2020		630	4030	125	500	4810		400	5150	140
			710	2270	100	710	4540		560	5390	140	450	5790	
			800	2560		800	5120	140	630	6060		500	6420	
450	90 x 170	120 x 210	900	2880		900	5760		710	6830		560	7190	160
			1000	3200	110	1000	6400	160	800	7690	160	630	8090	

The coupling selection is based on an ambient temperature up to +30 °C. The selection is based on a minimum safety factor of 2 versus the max. coupling torque ($T_{K \max}$). A detailed selection is possible according to catalogue, page 14 et seqq. Drives with periodical torque curves must be selected according to DIN 740 part 2. If requested, KTR will perform the selection. Torque T = rated torque according to Siemens catalogue M 11 · 1994/95.

¹⁾ For dimensions see ROTEX® GS series

²⁾ For motor hub made of steel see page 40

Cylindrical bores and spline bores

ROTEX® size		Stock programme of cylindrical finish bores [mm] H7 feather keyway acc. to DIN 6885 sheet 1 [JS9] and thread for setscrews																																				
Material	Un-bored	Ø6	Ø8	Ø9	Ø10	Ø11	Ø12	Ø14	Ø15	Ø16	Ø17	Ø18	Ø19	Ø20	Ø22	Ø24	Ø25	Ø26	Ø30	Ø32	Ø35	Ø38	Ø40	Ø42	Ø45	Ø48	Ø50	Ø55	Ø60	Ø65	Ø70	Ø75	Ø80	Ø85	Ø90	Ø100		
14	Sint	•																																				
	Al-H	•	•	•	•	•	•	•	•	•																												
19	Sint	•																																				
	Al-D	•	•	•	•	•	•	•	•	•	•	•	•	•	•	•	•	•	•	•	•	•	•	•	•	•	•	•	•	•	•	•	•	•	•	•	•	•
	St	•	•	•	•	•	•	•	•	•	•	•	•	•	•	•	•	•	•	•	•	•	•	•	•	•	•	•	•	•	•	•	•	•	•	•	•	•
24	Sint	•																																				
	Al-D	•			•	•	•	•	•	•	•	•	•	•	•	•	•	•	•	•	•	•	•	•	•	•	•	•	•	•	•	•	•	•	•	•	•	•
	St	•			•	•	•	•	•	•	•	•	•	•	•	•	•	•	•	•	•	•	•	•	•	•	•	•	•	•	•	•	•	•	•	•	•	•
28	Al-D	•																																				
	St	•																																				
38	GJL	•																																				
	St	•																																				
42	GJL	•																																				
	St	•																																				
48	GJL	•																																				
	St	•																																				
55	GJL	•																																				
	St	•																																				
65	GJL	•																																				
	St	•																																				
75	GJL	•																																				
	St	•																																				
90	GJL	•																																				
	St	•																																				

Basic programme of SAE involute spline												
Spline code	Size	Pitch circle	Pitch	No. of teeth	Angle	Spline code	Size	Pitch circle	Pitch	No. of teeth	Angle	
PH-S	5/8"	14.28	16/32	9	30°	PS-S	1 1/2"	35.98	12/24	17	30°	
PI-S	3/4"	17.46	16/32	11	30°	PD-S	1 1/2"	36.51	16/32	23	30°	
PB-S	7/8"	20.63	16/32	13	30°	PE-S	1 3/4"	42.86	16/32	27	30°	
PB-BS	1"	23.81	16/32	15	30°	PK-S	1 3/4"	41.275	8/16	13	30°	
PJ	1 1/8"	26.98	16/32	17	30°	PT-C ¹⁾	2"	47.625	8/16	15	30°	
PC-S	1 1/4"	29.63	12/24	14	30°	PQ-C ¹⁾	2 1/4"	53.975	8/16	17	30°	
PA-S	1 3/8"	33.33	16/32	21	30°							

Basic programme of spline bores acc. to DIN 5482										
Size	Pitch circle	Module	No. of teeth	Profile correction	Size	Pitch circle	Module	No. of teeth	Profile correction	
A 17 x 14	14.40	1.6	9	+0.600 ²⁾	A 35 x 31	31.50	1.75	18	+0.676	
A 20 x 17	19.20	1.6	12	-0.2	A 40 x 36	38.00	1.9	20	+0.049	
A 25 x 22	22.40	1.6	14	+0.550	A 45 x 41	44.00	2	22	+0.181	
A 28 x 25	26.25	1.75	15	+0.302	A 50 x 45	48.00	2	24	+0.181	
A 30 x 27	28.00	1.75	16	+0.327						

Basic programme of spline bores acc. to DIN 5480								
Spline code	Pitch circle	Module	No. of teeth	Spline code	Pitch circle	Module	No. of teeth	
20 x 1 x 18 x 7H	18.0	1	18	40 x 2 x 18 x 8H	36.0	2	18	
20 x 1.25 x 14 x 7H	17.5	1.25	14	45 x 2 x 21 x 7H	41.0	2	21	
25 x 1.25 x 18 x 7H	22.5	1.25	18	48 x 2 x 22 x 9H	44.0	2	22	
28 x 1.25 x 21 x 7H	26.25	1.25	21	50 x 2 x 24 x 8H	48.0	2	24	
30 x 2 x 14 x 7H	26.0	2	14	60 x 2 x 28 x 8H	56.0	2	28	
32 x 2 x 14 x 8H	28.0	2	14	75 x 3 x 24 x 7H	72.0	3	24	
35 x 2 x 16 x 8H	32.0	2	16	80 x 3 x 25 x 8H	75.0	3	25	

Basic programme of spline bores acc. to DIN 9611 - ISO 500 (p.t.o. shaft connection)				
Size	Width of keyway	No. of teeth	Tip circle	Root circle
1 3/8"	8.69	6	34.93	29.65
1 3/8"	-	21	34.95	34.80 ³⁾
1 3/4"	11.07	6	44.45	37.74
1 3/4"	-	20	45.20	40.20

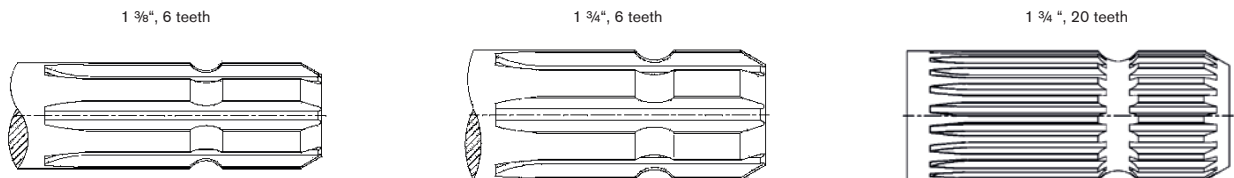

Spline clamping hubs are often adapted to the shafts of hydraulic pumps/hydraulic motor shafts. Please contact us for the respective hub length of the spline code!

¹⁾ For clamping hubs only, with plug-in hubs use code PT or PQ.

²⁾ Profile correction different from DIN

³⁾ Similar to code PA-S

Inch bores and taper bores

Stock programme of inch bores						Size									
Bore and keyway acc. to ANSI/AGMA 9002-C14 Bore (clearance fit) Keyway (commercial class fit)						19	24	28	38	42	48	55	65	75	90
KTR code	Ø bore ["]	Width of keyway ["]	Ø bore [mm]	Width of keyway [mm]	Keyway depth/ Tolerance +0.381 [mm]	Steel				Cast iron (GJL)					
Tb	3/8	1/8	9.525 ^{+0.0254}	3.175 ^{+0.051}	10.972										
DNB	7/16	3/32	11.112 ^{+0.0254}	2.382 ^{+0.051}	12.293										
T	1/2	3/16	12.7 ^{+0.0254}	4.762 ^{+0.051}	14.757										
Ta	1/2	1/8	12.7 ^{+0.0254}	3.175 ^{+0.051}	14.224	●	●								
DNC	17/32	1/8	13.495 ^{+0.0254}	3.175 ^{+0.051}	15.011										
Do	9/16	1/8	14.287 ^{+0.0254}	3.175 ^{+0.051}	15.824										
E	5/8	1/8	15.875 ^{+0.0254}	3.175 ^{+0.051}	17.424										
Es	5/8	5/32	15.875 ^{+0.0254}	3.968 ^{+0.051}	17.729	●	●	●							
Ed	5/8	3/16	15.875 ^{+0.0254}	4.762 ^{+0.051}	18.008	●	●								
DNH	11/16	3/16	17.462 ^{+0.0254}	4.762 ^{+0.051}	19.634										
Ad	3/4	1/8	19.05 ^{+0.0254}	3.175 ^{+0.051}	20.624										
A	3/4	3/16	19.05 ^{+0.0254}	4.762 ^{+0.051}	21.259	●	●	●	●						
G	7/8	3/16	22.225 ^{+0.0254}	4.762 ^{+0.051}	24.485	●	●	●	●	●					
F	7/8	1/4	22.225 ^{+0.0254}	6.35 ^{+0.051}	25.069		●	●	●	●					
Gf	15/16	1/4	23.812 ^{+0.0254}	6.35 ^{+0.051}	26.695										
H	1	3/16	25.4 ^{+0.0254}	4.762 ^{+0.051}	27.686										
Hs	1	1/4	25.4 ^{+0.0254}	6.35 ^{+0.051}	28.295		●	●	●	●					
R	1 1/16	3/16	26.987 ^{+0.0254}	4.762 ^{+0.051}	29.286										
Sb	1 1/8	1/4	28.575 ^{+0.0254}	6.35 ^{+0.051}	31.521		●	●	●	●					
Sd	1 1/8	5/16	28.575 ^{+0.0254}	7.937 ^{+0.051}	32.105										
Js	1 1/4	1/4	31.75 ^{+0.0254}	6.35 ^{+0.051}	34.721				●						
K	1 1/4	5/16	31.75 ^{+0.0254}	7.937 ^{+0.051}	35.331			●	●	●	●	●			
Ma	1 3/8	5/16	34.925 ^{+0.0254}	7.937 ^{+0.051}	38.557			●	●						
RH1	1 3/8	3/8	34.925 ^{+0.0254}	9.525 ^{+0.063}	39.141										
Cb	1 7/16	3/8	36.512 ^{+0.0254}	9.525 ^{+0.063}	40.767										
Ca	1 1/2	5/16	38.1 ^{+0.0254}	7.937 ^{+0.051}	41.783										
C	1 1/2	3/8	38.1 ^{+0.0254}	9.525 ^{+0.0635}	42.392				●	●	●	●	●	●	
Nb	1 5/8	3/8	41.275 ^{+0.0254}	9.525 ^{+0.0635}	45.618				●	●					
Ls	1 3/4	3/8	44.45 ^{+0.0254}	9.525 ^{+0.0635}	48.818										
L	1 3/4	7/16	44.45 ^{+0.0254}	11.112 ^{+0.0635}	49.428										
Lu	1 7/8	1/2	47.625 ^{+0.0254}	12.7 ^{+0.0635}	53.238					●					
Da	1 15/16	1/2	49.212 ^{+0.0254}	12.7 ^{+0.0635}	54.864										
Ds	2	1/2	50.8 ^{+0.0254}	12.7 ^{+0.0635}	56.464										
Pa	2 1/8	1/2	53.975 ^{+0.0381}	12.7 ^{+0.063}	59.69										
U	2 1/4	1/2	57.15 ^{+0.0381}	12.7 ^{+0.063}	62.915										
Ub	2 3/8	5/8	60.325 ^{+0.0381}	15.875 ^{+0.076}	67.335										
Wd	3 3/8	7/8	85.725 ^{+0.0381}	22.225 ^{+0.076}	95.504										
Wf	3 5/8	7/8	92.075 ^{+0.0381}	22.225 ^{+0.076}	101.955										

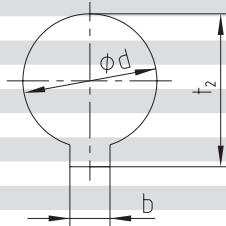

Basic programme taper 1:8					
Code	d ^{+0.05}	(d ₂)	b ^{JS9}	t ₂ ^{+0.1}	l _k
N/1	9.7	7.575	2.4 ^{+0.05}	10.85	17.0
N/1c	11.6	9.5375	3 ^{JS9}	12.90	16.5
N/1e	13.0	10.375	2.4 ^{+0.05}	13.80	21.0
N/1d	14.0	11.813	3 ^{JS9}	15.50	17.5
N/1b	14.3	11.8625	3.2 ^{+0.05}	15.65	19.5
N/2	17.287	14.287	3.2 ^{+0.05}	18.24	24.0
N/2a	17.287	14.287	4 ^{JS9}	18.94	24.0
N/2b	17.287	14.287	3 ^{JS9}	18.34	24.0
N/3	22.002	18.502	4 ^{JS9}	23.40	28.0
N/4	25.463	20.963	4.78 ^{+0.05}	27.83	36.0
N/4b	25.463	20.963	5 ^{JS9}	28.23	36.0
N/4a	27.0	22.9375	4.78 ^{+0.05}	28.80	32.5
N/4g	28.45	23.6375	6 ^{JS9}	29.32	38.5
N/5	33.176	27.676	6.38 ^{+0.05}	35.39	44.0
N/5a	33.176	27.676	7 ^{JS9}	35.39	44.0

With code N/6 and N/6a keyway in parallel with taper.

Basic programme taper 1:10					
Code	d ^{+0.05}	(d ₂)	b ^{JS9}	t ₂ ^{+0.1}	l _k
CX	19.95	16.75	5 ^{JS9}	22.08	32
DX	24.95	20.45	6 ^{JS9}	26.68	45
EX	29.75	24.75	8 ^{JS9}	31.88	50

Basic programme taper 1:5					
Code	d ^{+0.05}	(d ₂)	b ^{JS9}	t ₂ ^{+0.1}	l _k
A-10	9.85	7.55	2 ^{JS9}	1.0	11.5
B-17	16.85	13.15	3 ^{JS9}	1.8	18.5
C-20	19.85	15.55	4 ^{JS9}	2.2	21.5
Cs-22	21.95	17.65	3 ^{JS9}	1.8	21.5
D-25	24.85	19.55	5 ^{JS9}	2.9	26.5
E-30	29.85	23.55	6 ^{JS9}	2.6	31.5
F-35	34.85	27.55	6 ^{JS9}	2.6	36.5
G-40	39.85	32.85	6 ^{JS9}	2.6	35.0

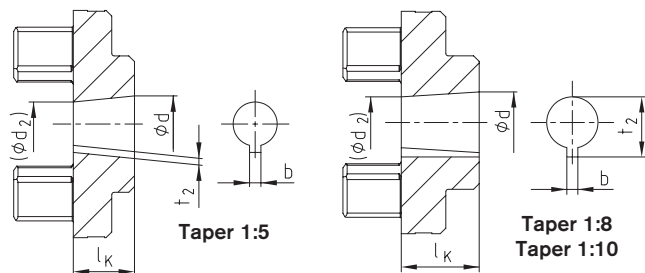

Morskate®



Any questions? Please contact us.

Morskate Aandrijvingen BV

Oosterveldsingel 47A
7558 PJ Hengelo (Ov)
The Netherlands

NL

T +31 (0)74 - 760 11 11
info@morskateaandrijvingen.nl
www.morskateaandrijvingen.nl

DE

T +49 692 - 222 34 95
info@morskateantriebstechnik.de
www.morskateantriebstechnik.de

EN

T +31 (0)74 - 760 11 11
info@morskatedrivetechnology.com
www.morskatedrivetechnology.com