

### Specificaties

- medium: perslucht, gefilterd
- instelbare einddemping
- aluminium cilinderbuis en eindkappen, chroomstalen zuigerstang, polyurethaan neuspakking, sinterbrons lager

omgevingstemperatuur  
0°C tot +80°C

-20°C tot +80°C bij droge lucht

werkdruk  
1 tot 10 bar

pag. 126

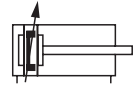

### Bestelsleutel

Serie	DWIC	ISO 1552 cilinder met instelbare einddemping
Boring	32, 40, 50, 63, 80, 100, 125 mm	
Slaglengte	25, 50, 80, 100, 125, 150, 160, 200, 250, 300, 320, 400, 450, 500 mm	
Magneet	S	magneet voor positiedetectie

voorbeeld:

DWIC - 50 - 125 - S

### Artikelnummers DWIC cilinders

Slaglengte (mm)	Ø cilinder						
	32	40	50	63	80	100	125
25	PI30500	PI30524	PI30548	PI30572	PI30596	PI30620	PI30644
50	PI30501	PI30525	PI30549	PI30573	PI30597	PI30621	PI30645
80	PI30502	PI30526	PI30550	PI30574	PI30598	PI30622	PI30646
100	PI30503	PI30527	PI30551	PI30575	PI30599	PI30623	PI30647
125	PI30504	PI30528	PI30552	PI30576	PI30600	PI30624	PI30648
150	PI30505	PI30529	PI30553	PI30577	PI30601	PI30625	PI30649
160	PI30506	PI30530	PI30554	PI30578	PI30602	PI30626	PI30650
200	PI30507	PI30531	PI30555	PI30579	PI30603	PI30627	PI30651
250	PI30508	PI30532	PI30556	PI30580	PI30604	PI30628	PI30652
300	PI30509	PI30533	PI30557	PI30581	PI30605	PI30629	PI30653
320	PI30510	PI30534	PI30558	PI30582	PI30606	PI30630	PI30654
400	PI30511	PI30535	PI30559	PI30583	PI30607	PI30631	PI30655
450	PI30512	PI30536	PI30560	PI30584	PI30608	PI30632	PI30656
500	PI30513	PI30537	PI30561	PI30585	PI30609	PI30633	PI30657
niet standaard	PI30240	PI30225	PI30226	PI30229	PI30239	PI30241	PI30242

Any questions? Please contact us.

**Morskate Aandrijvingen BV**  
Oosterveldsingel 47A  
7558 PJ Hengelo (Ov)  
The Netherlands

NL  
T +31 (0)74 - 760 11 11  
info@morskateaanrijvingen.nl  
www.morskateaanrijvingen.nl

DE  
T +49 692 - 222 34 95  
info@morskateantriebstechnik.de  
www.morskateantriebstechnik.de

EN  
T +31 (0)74 - 760 11 11  
info@morskatedrivetechnology.com  
www.morskatedrivetechnology.com



### Afmetingen DWIC cilinders

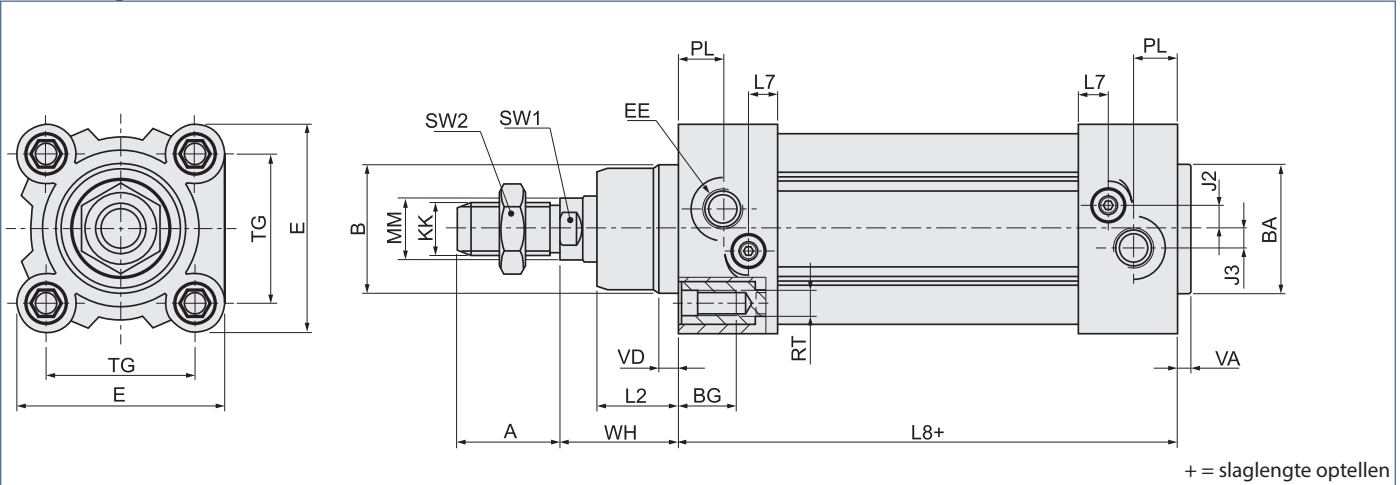

Ø cilinder	A	AF	B	BA	BG	E	EE	J2	J3	KK	L2	L7	L8+	MM	PL	RT	SW1	SW2	TG	VA	VD	WH
32	22	12	30	30	16	47	G1/8	5,7	5,3	M10x1,25	18	7	94	12	13	M6	10	17	32,5	4	5	26
40	24	12	35	35	16	54,5	G1/4	7,3	5	M12x1,25	22	9,2	105	16	14	M6	13	19	38	4	5	30
50	32	16	40	40	16	65	G1/4	7	6	M16x1,5	25,5	9	106	20	14	M8	17	24	46,5	4	6	37
63	32	16	45	45	16	75	G3/8	8	7,5	M16x1,5	26	8	121	20	16	M8	17	24	56,5	4	6	37
80	40	20	45	45	17	93	G3/8	8	7	M20x1,5	32	10,5	128	25	16	M10	22	30	72	4	7	46
100	40	20	55	55	17	110	G1/2	12	7	M20x1,5	38	10	138	25	18	M10	22	30	89	4	7	51
125	54	32	60	60	20	134	G1/2	10	7	M27x2	46	11	160	32	18	M12	27	41	110	6	10	65



Any questions? Please contact us.

**Morskate Aandrijvingen BV**  
Coosterveldsingel 47A  
7558 PJ Hengelo (Ov)  
The Netherlands

NL  
T +31 (0)74 - 760 11 11  
info@morskateaanrijvingen.nl  
www.morskateaanrijvingen.nl

DE  
T +49 692 - 222 34 95  
info@morskateantriebstechnik.de  
www.morskateantriebstechnik.de

EN  
T +31 (0)74 - 760 11 11  
info@morskatedrivetechnology.com  
www.morskatedrivetechnology.com



cilinders

hand- en mechanisch bediende ventielen

elektrisch bediende ventielen

luchtbediende ventielen

magneetventielen

luchtbediende schuine klepafsluiters

hulpventielen

aansluitmateriaal