

Morskate[®]
Gedreven door techniek

melior • motion[®]
Passion for precision.

PRECISION GEARS AT THE HIGHEST LEVEL

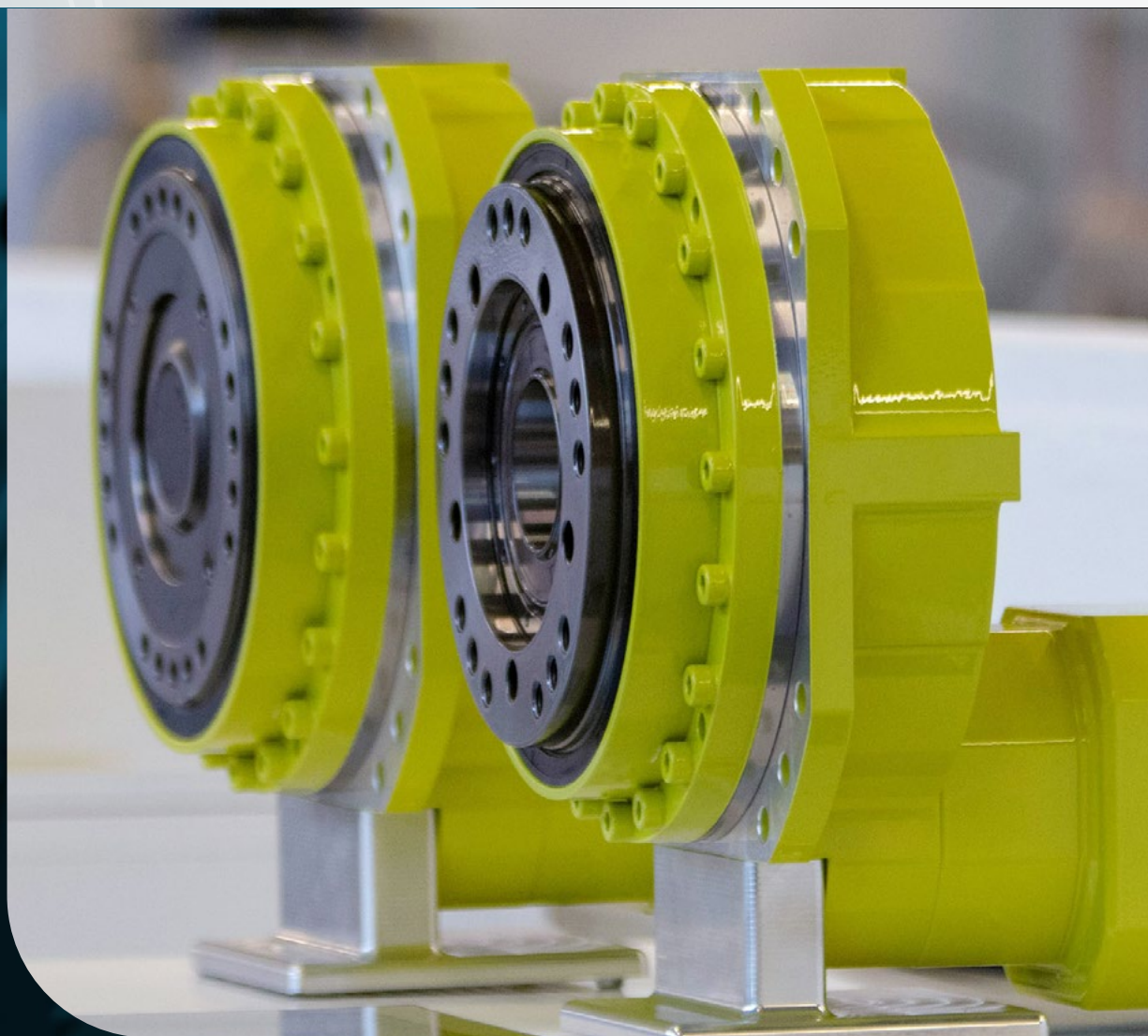

The better connection between motor and application

Melior Motion means "better movement", and that is what drives us: To offer gears with the best performance - for applications with the highest demands on precision and efficiency.

With this goal we have established ourselves as an independent company: specialising in innovative precision gears with a patented unique technology. For the demanding requirements in automation applications and robotics.

TABLE OF CONTENTS

PSC gearboxes	4
PSC gearboxes and application areas	4
Technical information PSC gearboxes	6
Versions	9
Structure	12
Advantages at a glance	14
Technical data of PSC gearboxes	16
Performance data Version with solid shaft	16
Performance data Version with hollow shaft	18
Mass moments of inertia	20
Dimensions three-stage gear units	21
Dimensions two-stage gear units	29
Gear Units PSC Series	30
Motor adaptations	32
Structure and components	33
Dimensions and weights	34
Mounting positions	37
PSC gearboxes with angular pre-stages	38
Mounting positions (angular pre-stage)	40
Output - possible variants	41
Gears made to measure (special gears)	42
Order code	43

We ...

... are Melior Motion GmbH.

... are a traditional company in Hameln, Lower Saxony, Germany.

... have over 100 years of experience in gear manufacturing.

... have been building precision gears for industrial robots since 1985.

... design, develop, produce and validate gearboxes.

... are internationally active.

© 2020 Melior Motion GmbH

All technical specifications correspond to the state of printing. Since we continuously improve our product range, the contents are subject to technical changes. Also errors can unfortunately not be completely excluded. The data, illustrations and descriptions in this catalogue can not be used as a basis for legal claims. Your exact specific requirements must be agreed with us. Information in this catalogue shall only become binding contents of the contract, if this has been agreed with us in writing.

All drawings, texts and other representations contained in this catalogue are protected property of **Melior Motion**.

Any further use in print or electronic media requires our express consent.

Photos: Peter Klassen, Markus Schrader

BETTER TECHNOLOGY FOR BETTER PERFORMANCE

Our precision gears are planetary gears with an integrated helical gear stage and thus, in comparison to other designs, are above all quieter, more energy-efficient and more controllable.

In the PSC gear unit product series, we have exploited all the advantages of planetary gear units and specifically optimised these for use in automation processes and robots

Unique on the market: Our patented system for wear regulation ensures consistent precision of the gearboxes during their entire service life - the PSC gearboxes readjust themselves automatically.

PSC transmissions - Precise | Silent | Constant

PSC gearboxes are precise:

The combination of maximum torsional and tilting rigidity and minimal backlash, our gears achieve the highest accuracy.

PSC gearboxes are silent:

The helical input stage makes them the quietest among all precision gear units.

PSC gearboxes are constant:

Precision remains constant over the entire service life of the gear unit, due to the patented design in the output stage.

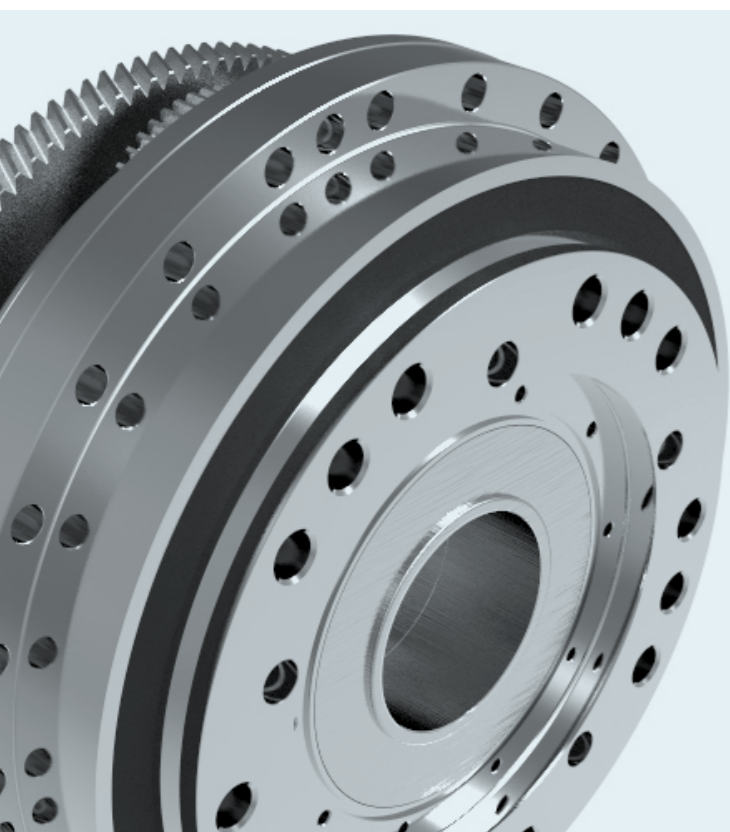

Precision landing for your application

With the backlash of less than 0.1 angular minutes, PSC gearboxes offer the best solution for high precision tasks.

The backlash is maintained at a constant level over the service life. Complex re-adjustment becomes unnecessary and the downtime enormously reduced.

Thanks to the integrated main bearing, the tilt and torsional stiffness is especially high - good for accuracy, smooth running and service life.

The low breakaway torque makes the PSC-gearbox easier to control - for example compared to cycloid gears. In addition, this allows the potential to use a smaller drive motor and control system.



ROBOTICS

Industrial Robots
Traversing axes



AUTOMATION

Handling systems
Pick-and-place applications
Automation systems
Transport systems



PACKAGING TECHNOLOGY

Palletizing systems
Pick-and-place applications
Handling
Transport systems



MACHINE TOOLS

Tool changer
Feeding systems
Rack and pinion applications



WELDING

Turntables
Positioner



MEDICAL TECHNOLOGY

MRT and CT equipment



SPECIAL MACHINES

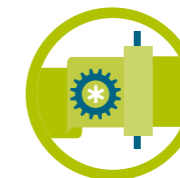

TEXTILE MACHINES

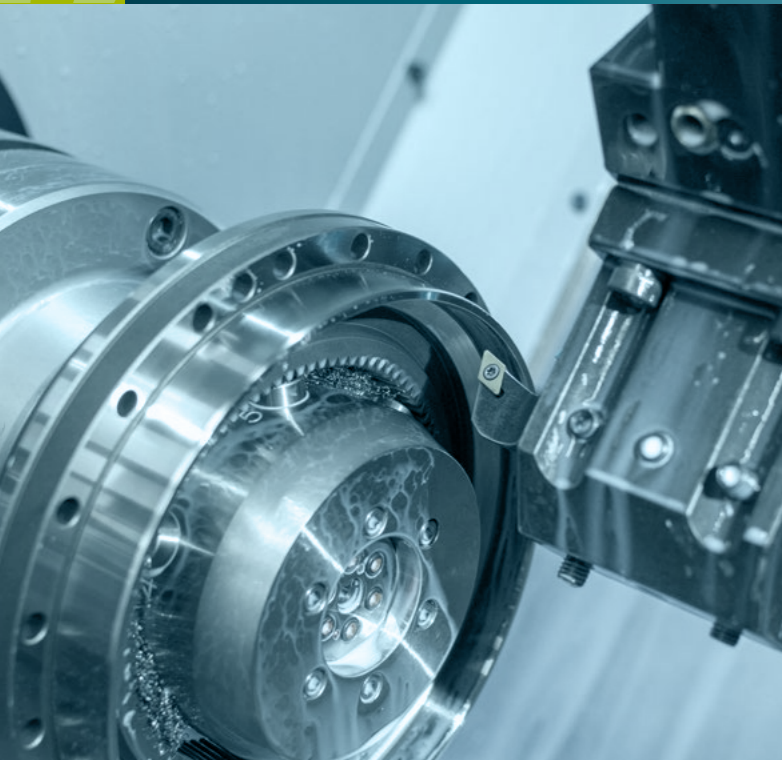

Quality made in Germany

The highest precision of our gears requires the highest precision in production. Our PSC gear units are produced in our own factory in Hamelin, Germany, for the highest demand on quality.

For this purpose we use the latest production technologies and a modern, semi-automated assembly line. The highest degree of precision is achieved through the most precise clamping technology, which has been especially developed for our production processes.

TORSIONAL STIFFNESS

Torsional stiffness is defined as the quotient of the torsional torque acting on the gear unit from outside and the resulting twisting angle at the output. This characteristic value is expressed in Nm/arcmin. To determine this parameter, the gear unit is mounted with the drive shaft blocked without backlash and the output loaded bidirectionally with a continuously increasing torque up to the nominal value. The torsional torque and the torsion angle at the output flange are measured by a suitable measuring sensor (hysteresis curve) and the torsional stiffness is evaluated in the value range between 50 % and 100 % of the nominal load.

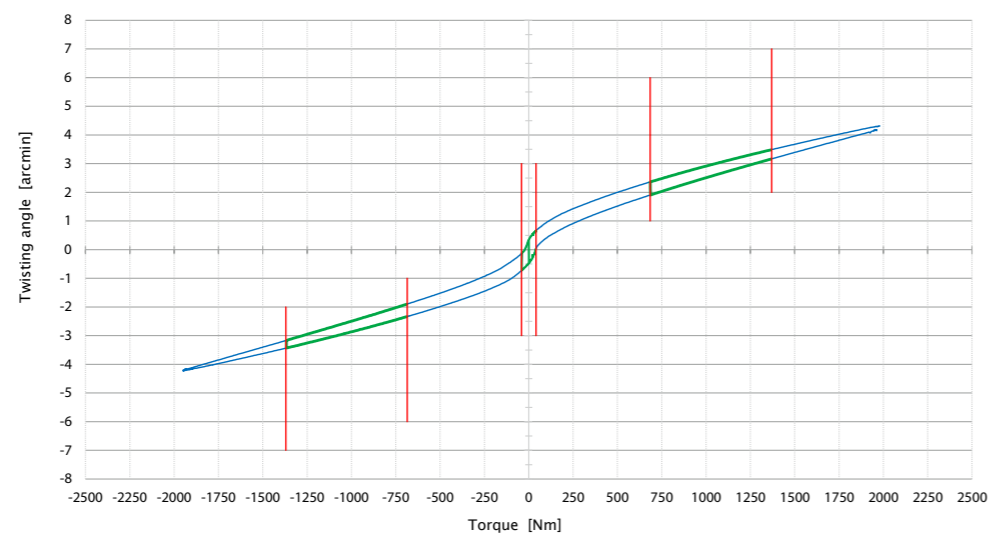

Illustration: Hysteresis curve using the example PSC160-V, Torsional stiffness (from practical test)

BACKLASH, LOST MOTION

The backlash of a gear unit describes the angular tolerance between output and input at a torque of 0 Nm. Lost motion, also called position error, describes the angle of twist at the output, within which the gearbox comes to a standstill after all external loads have been removed.

This characteristic value is specified in arcmin.

The measuring method for determining this parameter is basically the same as for the circumferential backlash described. However, an evaluation takes place in a value range of +/-3% of the nominal torque.

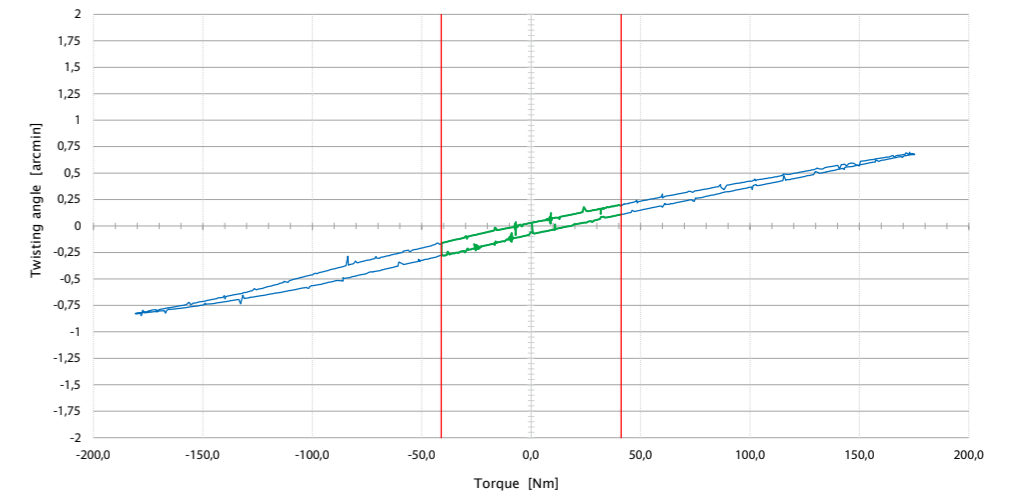

Illustration: Hysteresis curve using the example PSC160-V, Backlash, lost motion (from practical test)

TILTING STIFFNESS

The tilting rigidity is defined as the quotient of the bending moment resulting from external operating forces and the resulting tilt angle between output and housing flange. This characteristic value is specified in Nm/arcmin. To determine this parameter, the gear housing is mounted on a sufficiently rigid structure. The output is subjected to a continuously increasing bending moment up to the maximum allowable value and is loaded bidirectionally. By means of a suitable measuring sensor technology the torque as well as the tilt at the output flange is recorded (hysteresis curve) and the entire value range is evaluated to determine the tilting stiffness.

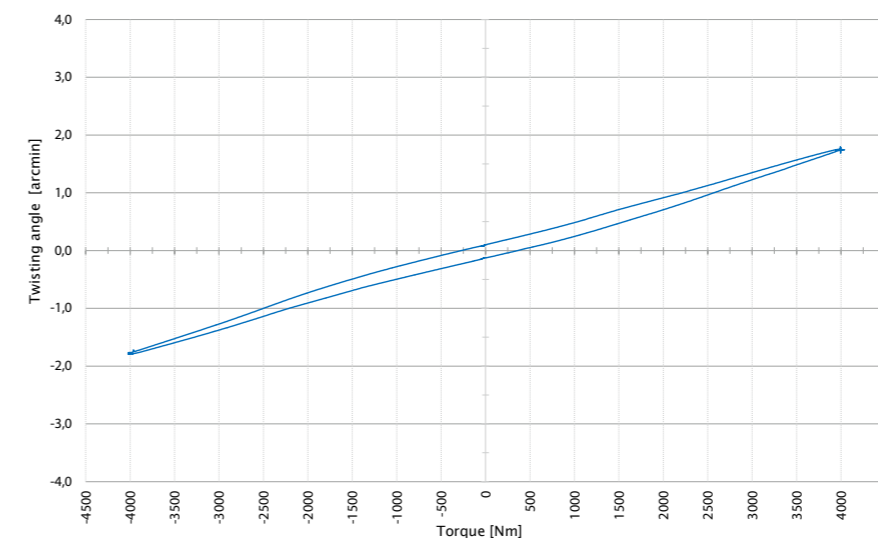

Illustration: Determination of tilt stiffness using an example PSC160-V (from practical test)

ANGULAR TRANSMISSION ACCURACY

The angular transmission accuracy defines the maximum translation error (max. amplitude of the fluctuation) of the real output rotary motion, related to the theoretically calculated output speed ratio value. Thus, it represents the transmission error during one revolution at the output. An indication of this value is given in angular seconds [arcsec].

To determine this parameter, the gear unit is rotated without load in trailing mode. Using a suitable measuring sensor, the input and output rotary motion is recorded. The value range over one full revolution of the output drive is evaluated to determine the synchronism accuracy.

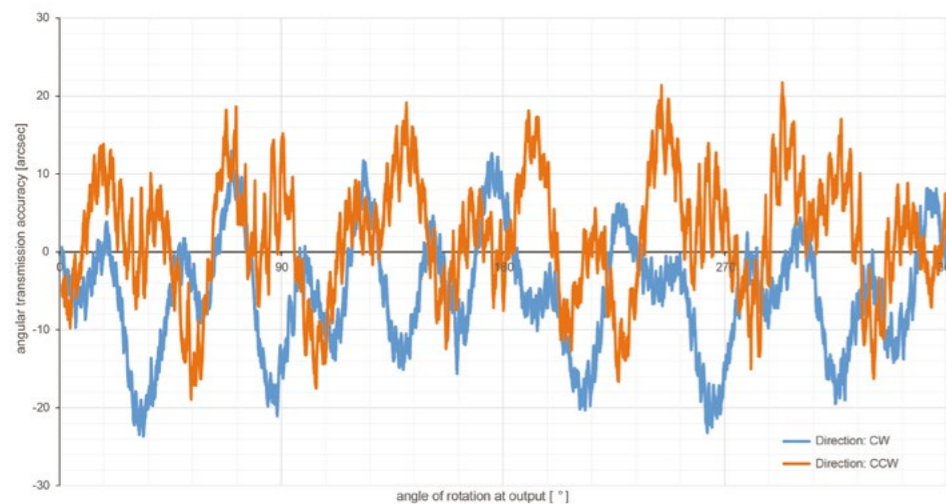
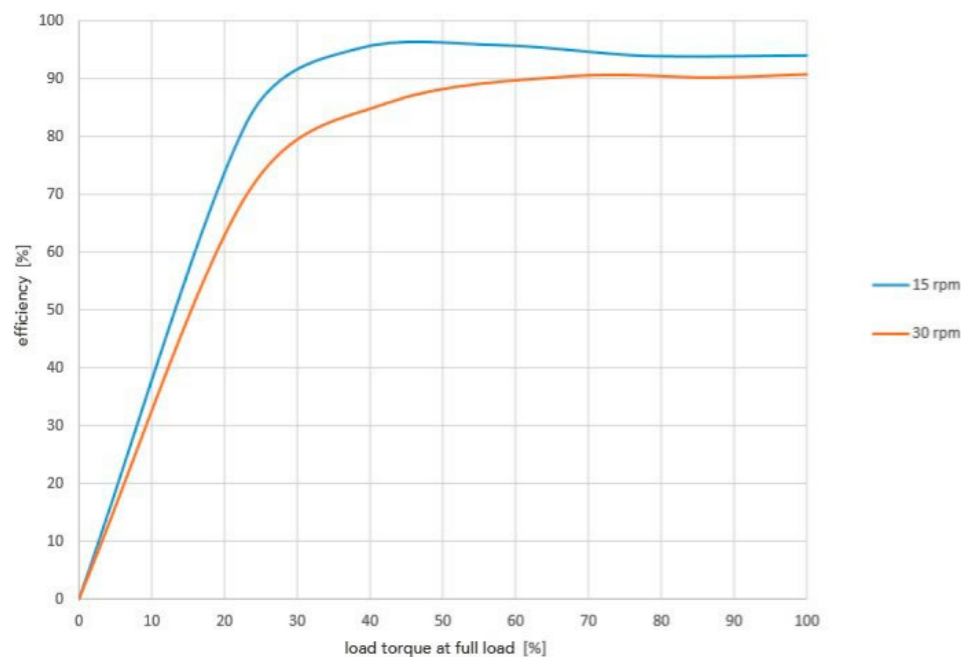

Illustration: Measurement of angular transmission accuracy at Example PSC160-V (from practical test)

EFFICIENCY

The efficiency [%] η is the ratio of output to input power and thus describes the efficiency of a technical device or system. Power losses in the form of friction mean that the efficiency is always less than 1 or less than 100%. The efficiency of PSC gearboxes is $\geq 90\%$.



Melior Motion's PSC gear units are available as a sub-assembly or as fully enclosed gear unit - in solid or hollow shaft design - in nine sizes. Hollow shafts with up to 126 mm bore diameter offerspace for passing data or supply lines through the gear unit.

Sub-assemblies can be integrated directly into your system. The ready-to-install fully enclosed gear units are suitable for easy plug-and-play connection to the motor.

Gearbox sub assembly PSC V/H-E

Fully enclosed gearbox PSC V/H-B

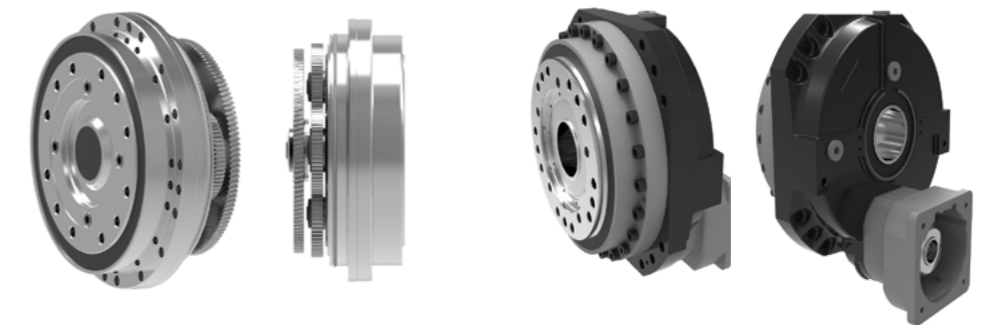

Solid shaft version V	✓	✓
Hollow shaft design H	✓	✓
Delivery with oil filling		✓
Food proof oil	✓	✓
Shaft seals	standard: NBR, VITON on request	
Painting		RAL 9005 black on request
Hollow shaft protective sleeve	✓	✓

Further possibilities on request

The sub-assembly and fully enclosed gear units are available in different versions - here are examples of a selection.

Sub-assembly with solid shaft

We supply the sub-assembly as standard always with separate input pinion and three-stage design.



Gear unit with solid shaft and free input shaft

The fully enclosed gear unit with free input shaft is suitable for mounting of belt drives or other drive components. It is also available with hollow shaft.



Sub-assembly with hollow shaft

We supply the sub-assembly as standard with loose input pinion and three-stage design. The hollow shafts with up to 126 mm inner diameter offer space to carry out supply lines.



Gear unit with hollow shaft and clamping hub

The version with clamping hub enables easy motor adaptation for all solid and hollow shaft gears. Instead of the clamping hub we use also metal bellows couplings (see page 33).



Sub-assembly as two-stage gear unit

On request, the sub-assemblies are also available as two-stage version. The sun pinion serves then as input pinion and can be directly connected to the motor shaft so that the drive is centred.



Gear unit with solid shaft and right angle pre-stage

For applications with limited space we offer gearboxes with additional right angle pre-stage. They are available with solid shaft as well as with hollow shaft.

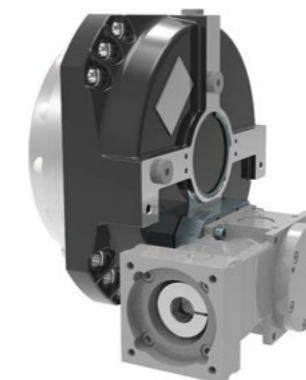

Our low-backlash PSC precision gears achieve a particularly high power-density thanks to multiple gear meshing of the structure with sun gear, planet gears and ring gear. Thereby the efficiency of over 90 percent and the extremely low breakaway torque offer outstanding energy efficiency.

This keeps the temperature of the gearbox at a particularly low level throughout. In addition, elastic seals such as radial sealing rings are much less stressed. It can be that - depending on the application or load cycles - 20,000 or even more operating hours can be achieved, far more than with conventional precision gears and verified in numerous tests.

At the same time, the low-backlash precision gear is extremely quiet. The noise in the working environment is thus reduced. Not only do the sub-assemblies operate quietly, but also precisely, even in the low torque range.

PSC gear units are available as planetary gear units with an integrated helical gear stage.

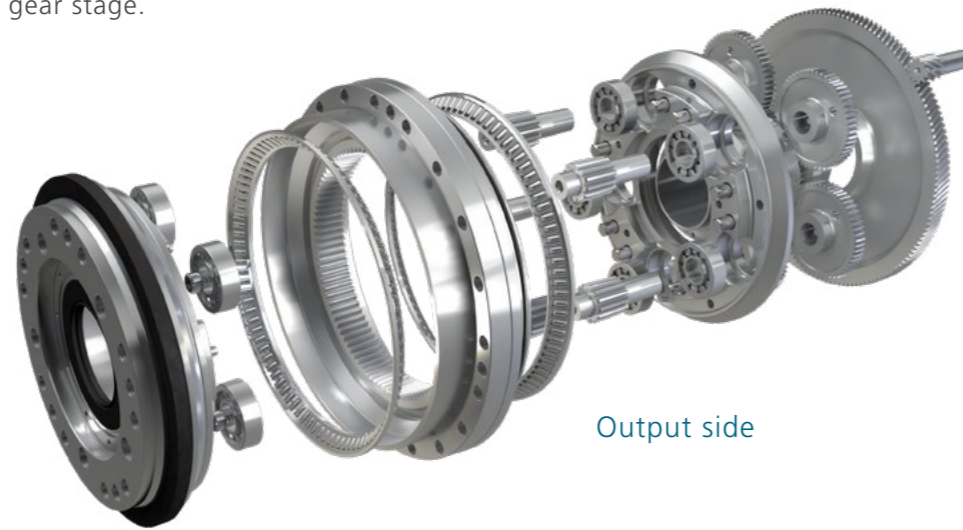

Output side

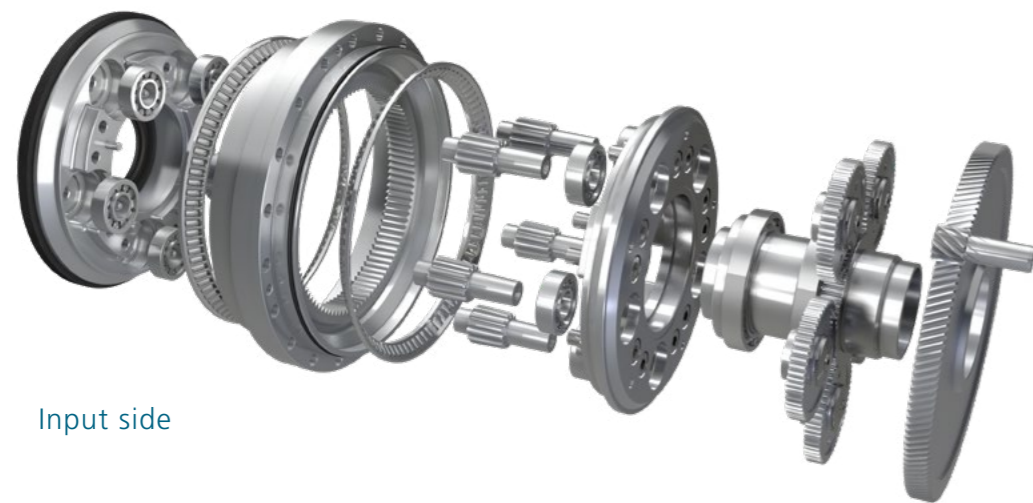

Input side

The macro and micro geometry are optimized for highest precision. Our patented solution for wear regulation ensures consistent precision over the entire service life.

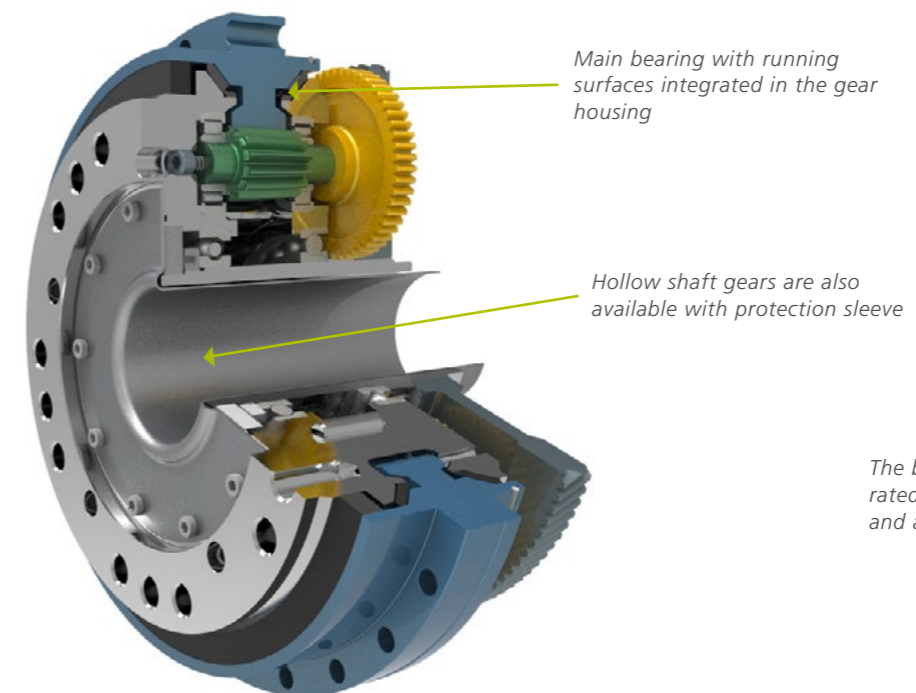
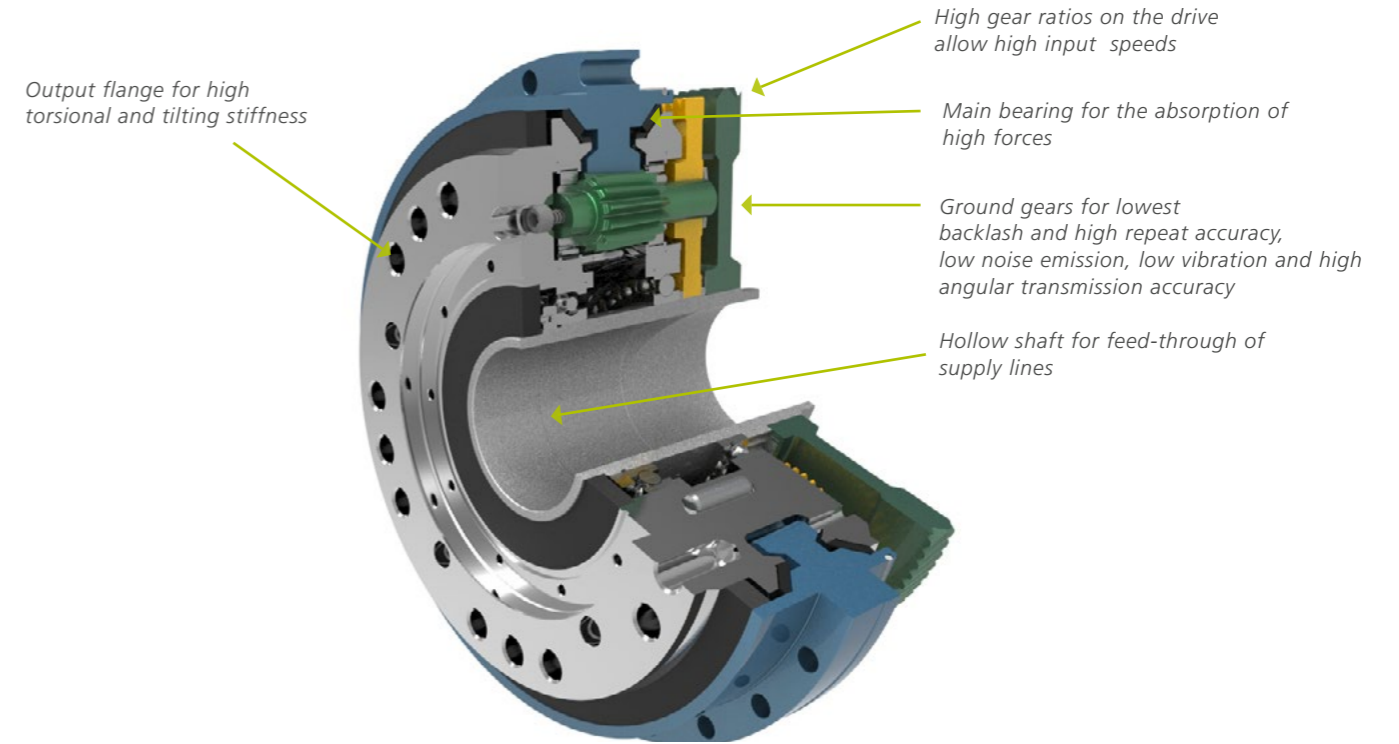

The bearing of the first stage gear is integrated in the gearbox, no external support and alignment is required

ADVANTAGE FOR YOUR APPLICATION

FEATURE OF PSC GEAR UNITS

Precise positioning	Extremely high tilting and torsional stiffness
Constant precision over the entire service life	Patent: Unique self-regulating gearing system
More safety for your application	High output, acceleration and emergency stop torques
High path accuracy	Low vibrations
Better controllability of the entire system	Low breakaway torque
Longer life of wearing parts and lubricants	Low heat generation
Good dynamic performance	Low mass moments of inertia
Overall system becomes lighter	Low mass of the gears
Smart construction	Compact design



Backlash $\leq 0,1$ arcmin

Advantage: Highest precision for your Application



Lost Motion $\leq 0,6$ arcmin

Advantage: Extremely high accuracy even in Low torque range



Service life 20,000 operating hours

Advantage: Higher utilisation



Efficiency at full load $>90\%$.

Advantage: Use of motors with lower power consumption



Running noise < 65 dB(A)

Advantage: Lower noise pollution in the Working environment

GEARBOX	Nominal ratio ¹⁾	exact ratio	Permanent output torque [Nm]	Nominal output torque ²⁾ [Nm]	Acceleration torque ³⁾ [Nm]	Emergency Stop Torque ⁴⁾ [Nm]	Permanent bending moment ⁵⁾ [Nm]	Emergency Stop bending moment max. ^{4),6)} [Nm]	max. Output speed ⁷⁾ [1/min]	Max. permissible average input speed ⁷⁾ [1/min]	Permissible average input speed ⁸⁾ [1/min]	Tilting stiffness ⁹⁾ [Nm/arcmin]	Torsional stiffness ¹⁰⁾ [Nm/arcmin]	max. axial force static ¹¹⁾ [kN]	max. radial force static ¹²⁾ [kN]	max. axial force dynamic ¹¹⁾ [kN]	max. radial force dynamic ¹²⁾ [Nm]	Power density [Nm/kg]	Weight ¹³⁾ [kg]	Backlash [arcmin] - output	Lost Motion [arcmin] - output	Angular transmission accuracy [arcsec]
PSC030-V	50	337183/6630	300	235	327	800	720	2,650	118	6,000	4,000	580	85	80	26.5	16.5	10.3	57	5.2	≤ 0.1	1.5	≤ 90
	63	359078/5525							92													
	80	376594/4641							74													
	100	389731/3978							61													
	125	402868/3315							49													
	160	416005/2652							38													
200	424763/2210	31																				
PSC056-V	50	564788/11745	575	445	625	1,545	1,070	3,645	120	5,771	4,000	1,170	165	152	55	18.0	11.0	75	7.7	≤ 0.1	≤ 0.6	≤ 70
	63	85946/1305							91													
	80	116641/1450							75													
	100	239421/2465							62													
	125	3508/29							50													
	160	251699/1595							38													
200	153475/783	31																				
PSC080-V	50	754/15	980	770	1,075	2,530	1,280	4,345	99	5,000	3,500	1,560	260	168	57	18.5	11.5	88	11.2	≤ 0.1	≤ 0.6	≤ 50
	63	33176/525							79													
	80	57304/735							64													
	100	1508/15							50													
	125	12818/105							41													
	160	1508/9							30													
200	107068/525	25																				
PSC112-V	50	325367/6525	1,480	1,165	1,630	3,780	2,410	5,910	100	4,986	3,500	2,230	430	270	85	29.5	18.0	93	15.9	≤ 0.1	≤ 0.6	≤ 50
	63	227143/3625							80													
	80	6139/75							61													
	100	42973/435							51													
	125	834904/6525							39													
	160	853321/5220							31													
200	288533/1450	25																				
PSC160-V	50	354928/6975	1,850	1,450	2,030	4,800	2,750	7,800	98	5,000	3,500	2,300	570	292	97	31.0	19.0	93	19.9	≤ 0.1	≤ 0.6	≤ 50
	63	3169/50							79													
	80	386618/4725							61													
	100	15845/162							51													
	125	136267/1050							39													
	160	415139/2700							33													
200	44366/225	25																				
PSC224-V	50	3531/70	2,325	1,820	2,550	6,090	3,060	9,280	89	4,500	3,000	2,620	680	315	100	32.0	20.0	84	27.7	≤ 0.1	≤ 0.6	≤ 50
	63	1584/25							71													
	71	11286/161							64													
	80	3828/49							58													
	100	11880/119							45													
	125	12177/98							36													
160	162	28																				
200	2079/10	22																				
PSC300-V	50	6338/125	3,435	2,690	3,765	8,990	4,800	11,410	79	4,000	2,500	5,490	1,130	400	140	42.5	26.5	92	37.4	≤ 0.1	≤ 0.6	≤ 50
	63	358097/5625							63													
	80	186971/2250							48													
	100	383449/3825							40													
	125	129929/1050							32													
	160	434153/2700							25													
200	440491/2250	20																				
PSC400-V	50	354928/6975	4,495	3,505	4,905	11,980	6,080	13,750	69	3,500	2,000	6,260	1,350	535	170	46.0	29.0	89	50.3	≤ 0.1	≤ 0.6	≤ 50
	63	3169/50							55													
	80	34859/450							45													
	100	9507/95							35													
	125	72887/600							29													
	160	224999/1350							21													
200	25352/125	17																				

General: Calculations are based on an output speed from n2=15 min-1
Calculations are valid for S5 intermittent operation;
for S1 continuous operation please contact us
Other ratios on request

- 1) Preferred ratios are in bold print.
- 2) Referred to 12 million x during lifetime.
- 3) Referred to 6 million x during the lifetime.
- 4) Referred to 3,000 times during lifetime.
- 5) Tilting moment for load case Fa= 0 and Fr= 0

- 6) A proof of the screw connection must be provided by the user!
(permissible strength class 12.9 for housing and output flange and 10.9 for cover flange)

- 7) Higher max. speeds are possible - please contact us
- 8) At nominal torque and 20 °C ambient temperature.
- 9) ±15 %
- 10) At 50 % to 100 % of nominal torque. +5% / -10%
- 11) Max. axial force for load case duration tilting torque= 0 and Fr= 0
- 12) Max. radial force for load case duration tilting torque= 0 and Fa= 0
- 13) The indicated mass refers to gear unit sub-assemblies nominal transmission ratio 50.

GEARBOX	Nominal ratio ¹⁾	exact ratio	Permanent output torque [Nm]	Nominal output torque ²⁾ [Nm]	Acceleration torque ³⁾ [Nm]	Emergency Stop Torque ⁴⁾ [Nm]	Permanent bending moment ⁵⁾ [Nm]	Emergency Stop bending moment max. ^{4) 6)} [Nm]	max. Output speed ⁷⁾ [1/min]	Max. permissible average input speed ⁷⁾ [1/min]	Permissible average input speed ⁸⁾ [1/min]	Tilting stiffness ⁹⁾ [Nm/arcmin]	Torsional stiffness ¹⁰⁾ [Nm/arcmin]	max. axial force static ¹¹⁾ [kN]	max. radial force static ¹²⁾ [kN]	max. axial force dynamic ¹¹⁾ [kN]	max. radial force dynamic ¹²⁾ [Nm]	Power density [Nm/kg]	Weight ¹³⁾ [kg]	Backlash [arcmin] - output	Lost Motion [arcmin] - output	Angular transmission accuracy [arcsec]
PSC057-H	35.5	2422/65	575	445	625	1,545	1,070	3,645	120	4.471	4,000	1,300	185	152	55	18.0	11.0	75	7.7	≤ 0.1	≤ 0.6	≤ 70
	45	15224/325							120	5.621												
	56	26296/455							104													
	71	22836/325							85													
	90	5882/65							66	6,000												
	125	4844/39							48													
PSC080-H	131.5	97572/715	980	770	1,075	2,530	1,280	4,345	44		3,500	2,730	305	168	57	18.5	11.5	88	11.2	≤ 0.1	≤ 0.6	≤ 50
	35.5	21614/611							100	3,537												
	45	82012/1833							100	4,474												
	56	169882/3055							90													
	71	43935/611							70													
	90	401273/4277							53	5,000												
PSC112-H	125	820120/6721	1,480	1,165	1,630	3,780	2,410	5,910	41		3,500	3,315	480	270	85	29.5	18.0	93	15.9	≤ 0.1	≤ 0.6	≤ 50
	131.5	8787/65							37													
	35.5	25422/725							100	3,506												
	45	26537/600							100	4,423												
	56	27429/500							91													
	71	28321/400							71													
PSC160-H	90	446/5	1,850	1,450	2,030	4,800	2,750	7,800	56	5,000	3,500	3,670	690	292	97	31.0	19.0	93	19.9	≤ 0.1	≤ 0.6	≤ 50
	125	3122/25							40													
	131.5	--							--													
	35.5	218327/6188							100	3,528												
	45	228342/5083							100	4,492												
	50	232348/4641							100													
PSC224-H	56	236354/4199	2,325	1,820	2,550	6,090	3,060	9,280	89		3,000	4,100	820	315	100	32.0	20.0	84	27.7	≤ 0.1	≤ 0.6	≤ 50
	71	244366/3315							68													
	90	250375/2652							53	5,000												
	125	292438/2431							42													
	131.5	294441/2210							38													
	35.5	206719/5733							90	3,245												
PSC300-H	45	324046/7007	3,435	2,690	3,765	8,990	4,800	11,410	90	4,162	2,500	8,810	1.240	400	140	42.5	26.5	92	37.4	≤ 0.1	≤ 0.6	≤ 50
	56	94979/1729							82													
	71	681614/9555							63													
	90	698375/7644							49	5,000												
	125	776593/6370							37													
	131.5	--							--													
PSC400-H	35.5	228342/6409	4,495	3,505	4,905	11,980	6,080	13,750	80	2,850	2,000	10,250	1.460	535	170	46.0	29.0	89	50.3	≤ 0.1	≤ 0.6	≤ 50
	45	14021/312							80	3,595												
	56	246369/4420							72													
	71	274411/3757							55													
	90	20030/221							44	4,000												
	125	2003/17							34													
PSC500-H	131.5	144216/1105	4,685	3,650	5,110	12,480	9,750	20,000	31		2,000	12,500	2.100	450	142	58.0	37.0	68	68.8	≤ 0.1	≤ 0.6	≤ 50
	35.5	12544/351							70	2,502												
	45	504/11							70	3,207												
	56	13440/247							64													
	71	4592/65							50													
	90	1176/13							39	3,500												
125	4816/39	28																				
	131.5	--							--													

General: Calculations are based on an output speed from n2=15 min-1
 Calculations are valid for S5 intermittent operation;
 for S1 continuous operation please contact us
 Other ratios on request

1) Preferred ratios are in bold print.
 2) Higher max. speeds are possible - please contact us.
 3) At nominal torque and 20 °C ambient temperature.
 4) Based on 12 million x during lifetime.

5) Based on 6 million x over the lifetime.
 6) Based on 3,000 x during the life time.
 7) Tilting moment for load case Fa= 0 and Fr= 0
 8) Max. axial force for load case duration tilting torque= 0 and Fr= 0
 9) Max radial force for load case duration tilting torque= 0 and Fa= 0

10) Proof of the screw connection must be provided by the user!
 (permissible strength class 12.9 for housing and output flange and 10.9 for cover flange)
 11) ±15 %
 12) At 50 % to 100 % of nominal torque. +5% / -10%
 13) The indicated mass refers to sub-assemblies nominal transmission ratio 35.5.

Mass moments of inertia related to the drive in kgcm²

Size	I_{nenn}	50	63	71	80	100	125	160	200
FULL SHAFT DESIGN	030V	0.50	0.36	--	0.26	0.20	0.15	0.10	0.07
	056V	1.01	0.75	--	0.51	0.35	0.24	0.16	0.12
	080V	1.92	1.43	--	0.96	0.67	0.45	0.31	0.22
	112V	3.37	2.52	--	1.69	1.19	0.80	0.54	0.39
	160V	3.37	2.52	--	3.30	2.31	1.56	1.05	0.76
	224V	10.29	7.69	6.48	5.16	3.62	2.44	1.64	1.18
	300V	16.92	12.64	--	8.48	5.95	4.01	2.70	1.94
	400V	27.87	20.83	--	13.97	9.80	6.60	4.45	3.20

Size	I_{nenn}	35.5	45	50	56	71	90	125	131.5
HOLLOW SHAFT DESIGN	057H	2.42	1.89	--	1.28	0.86	0.52	0.32	0.27
	080H	5.47	3.58	--	2.42	1.64	0.98	0.61	0.50
	112H	9.63	6.31	--	4.26	2.89	1.73	1.08	--
	160H	18.79	12.31	10.04	8.32	5.63	3.38	2.10	1.73
	224H	29.38	19.25	--	13.01	8.81	5.29	3.29	--
	300H	48.31	31.65	--	21.39	14.49	8.70	5.40	4.46
	400H	79.59	52.13	--	35.24	23.87	14.33	8.90	--
	500H	k. A.							

The mass moments of inertia mentioned are valid for version with input pinion: housing stationary and output shaft rotating.
Please inquire separately for mass moments of inertia for other drive options.

Exactly to μ

Precision from production to quality control is a must in the production of PSC gearboxes.

We guarantee the accuracy in testing using the highest quality measurement technology and fully air-conditioned rooms.

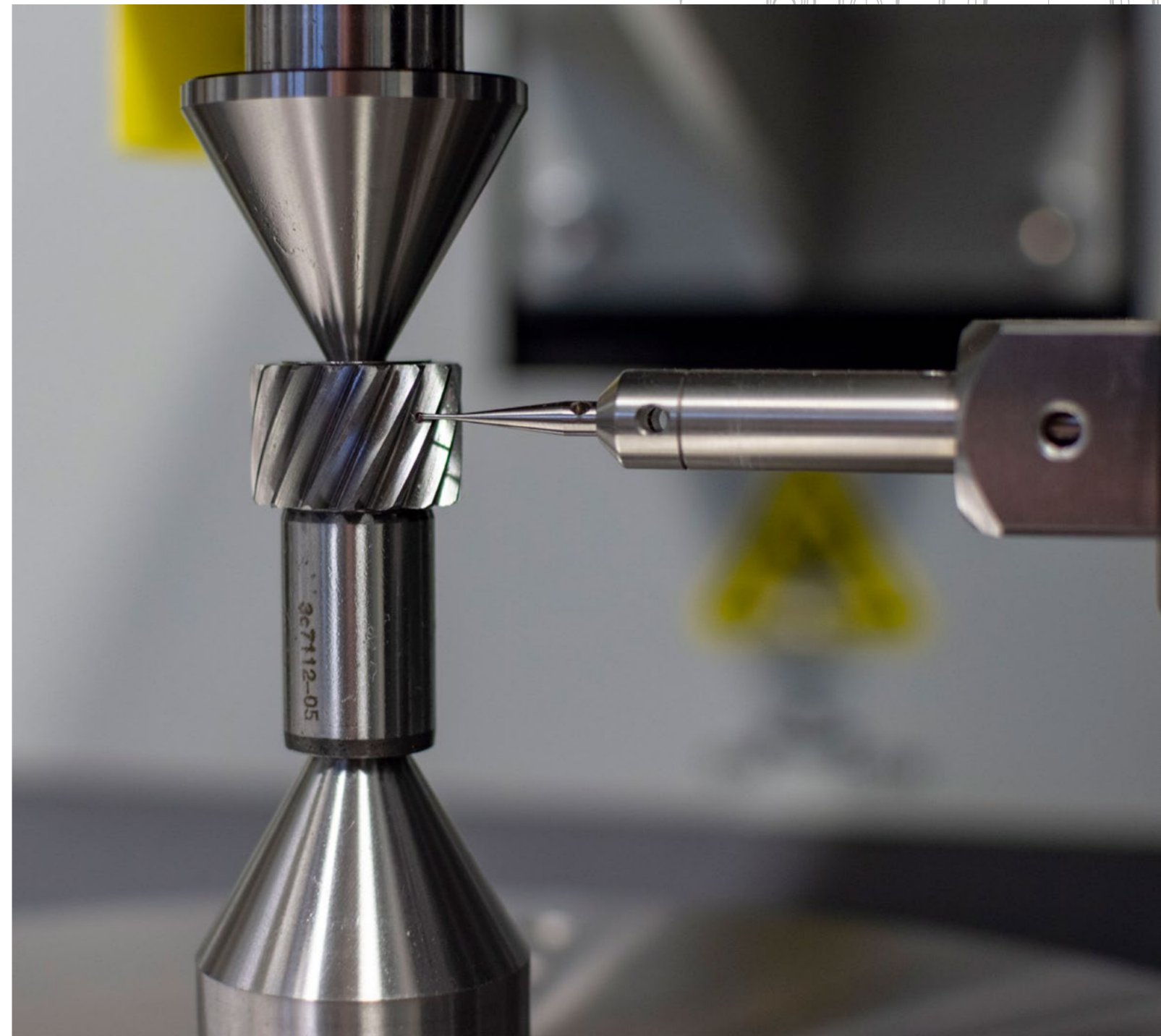
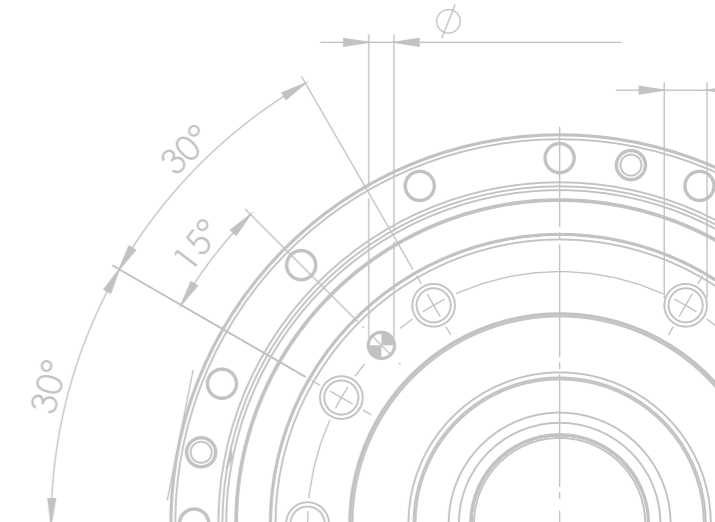

Gearbox size PSC030-V-E
(solid shaft, sub-assembly)

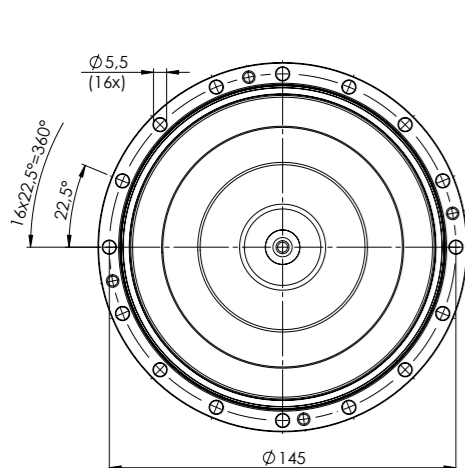
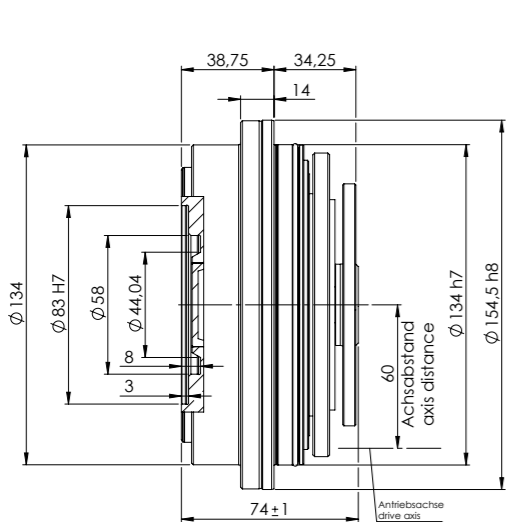
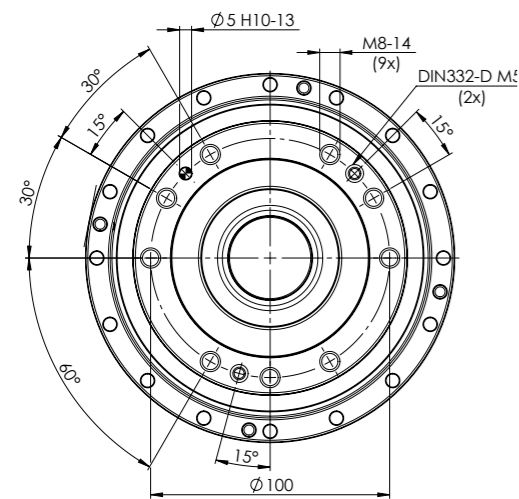

Gearbox size PSC056-V-E
(solid shaft, sub-assembly)

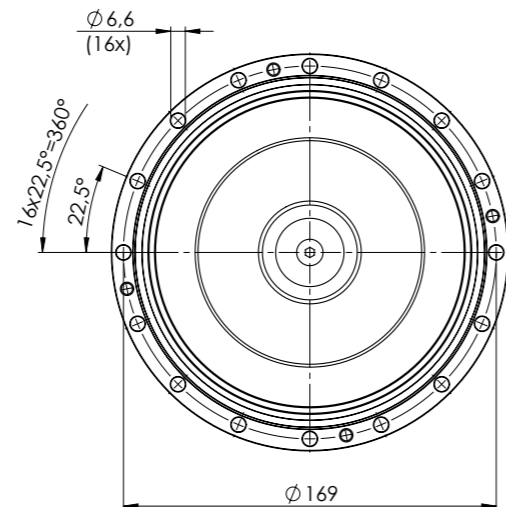
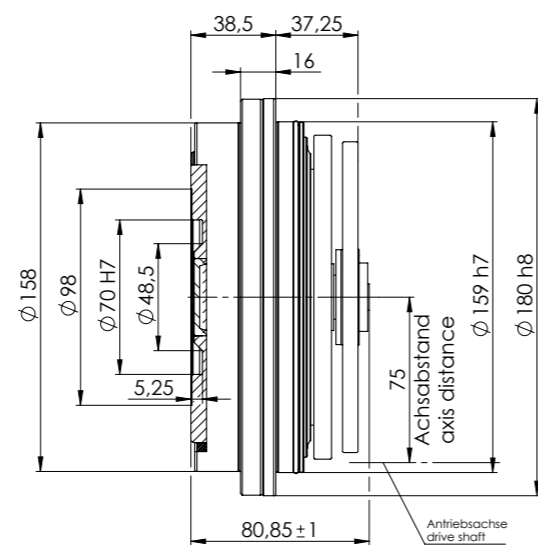
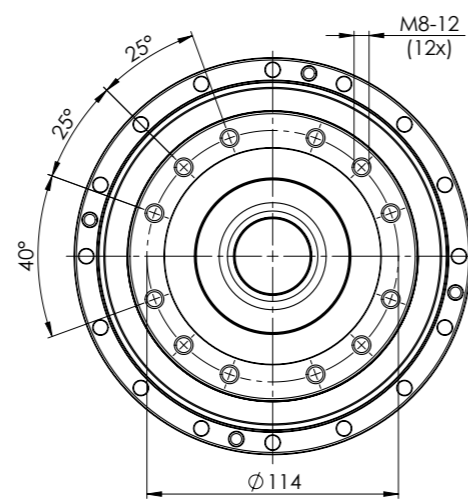

Gearbox size PSC080-V-E
(solid shaft, sub-assembly)

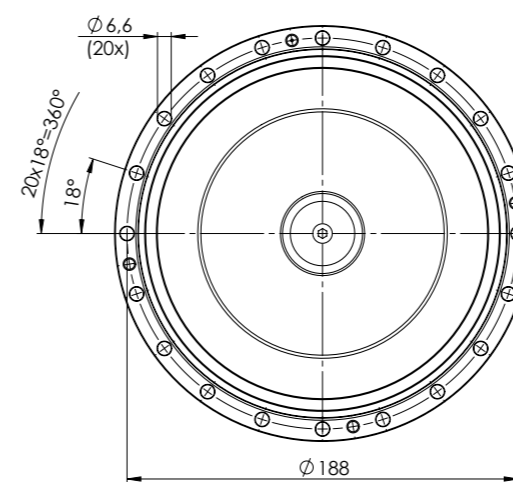
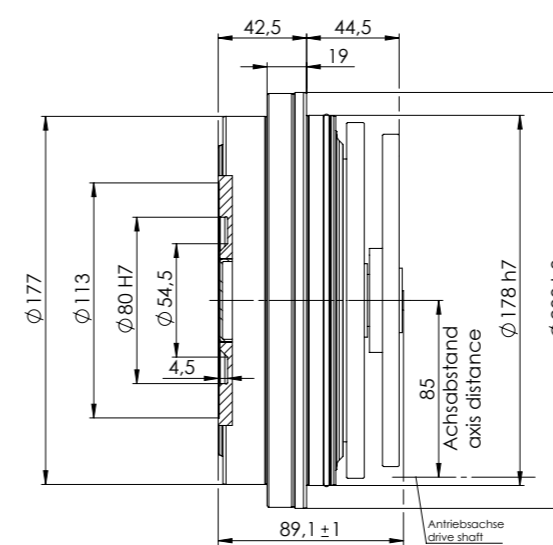
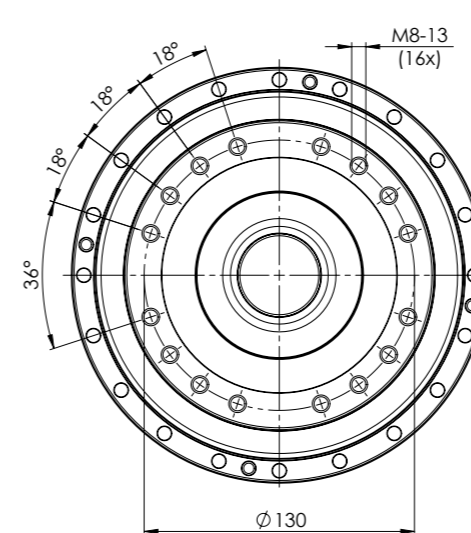

Gearbox size PSC112-V-E
(solid shaft, sub-assembly)

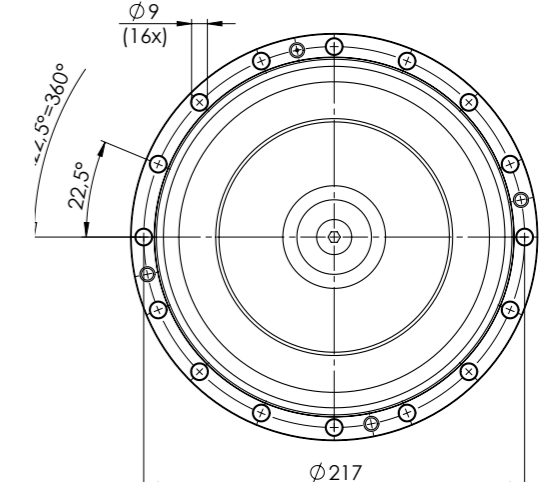
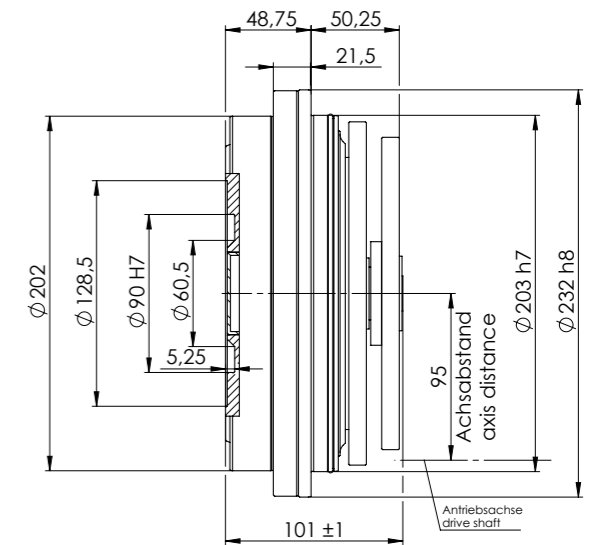
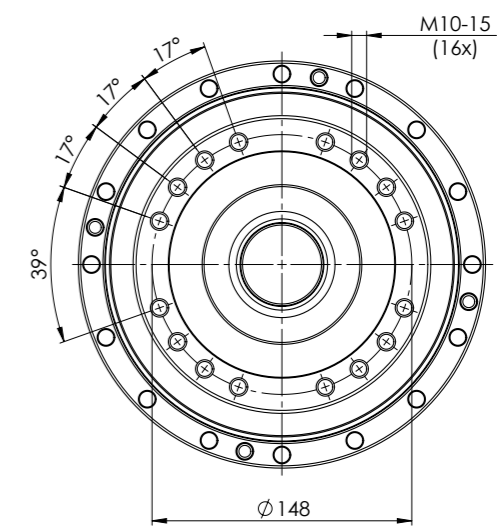

Gearbox size PSC160-V-E
(solid shaft, sub-assembly)

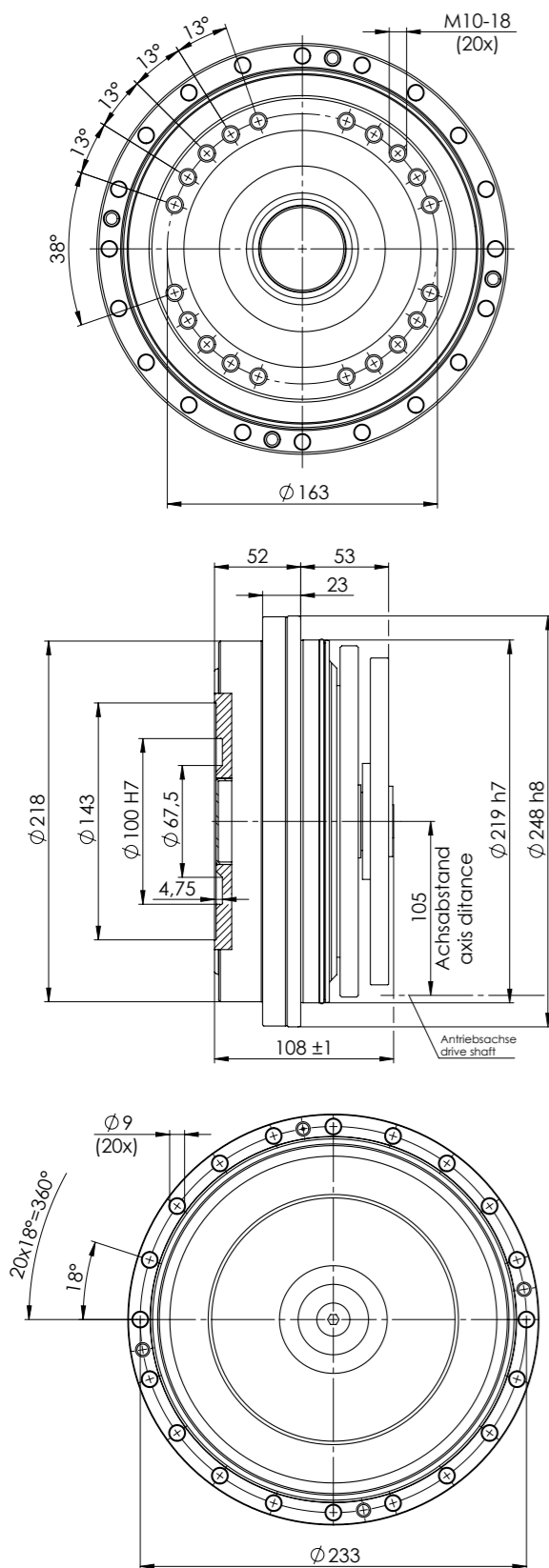

Gearbox size PSC224-V-E
(solid shaft, sub-assembly)

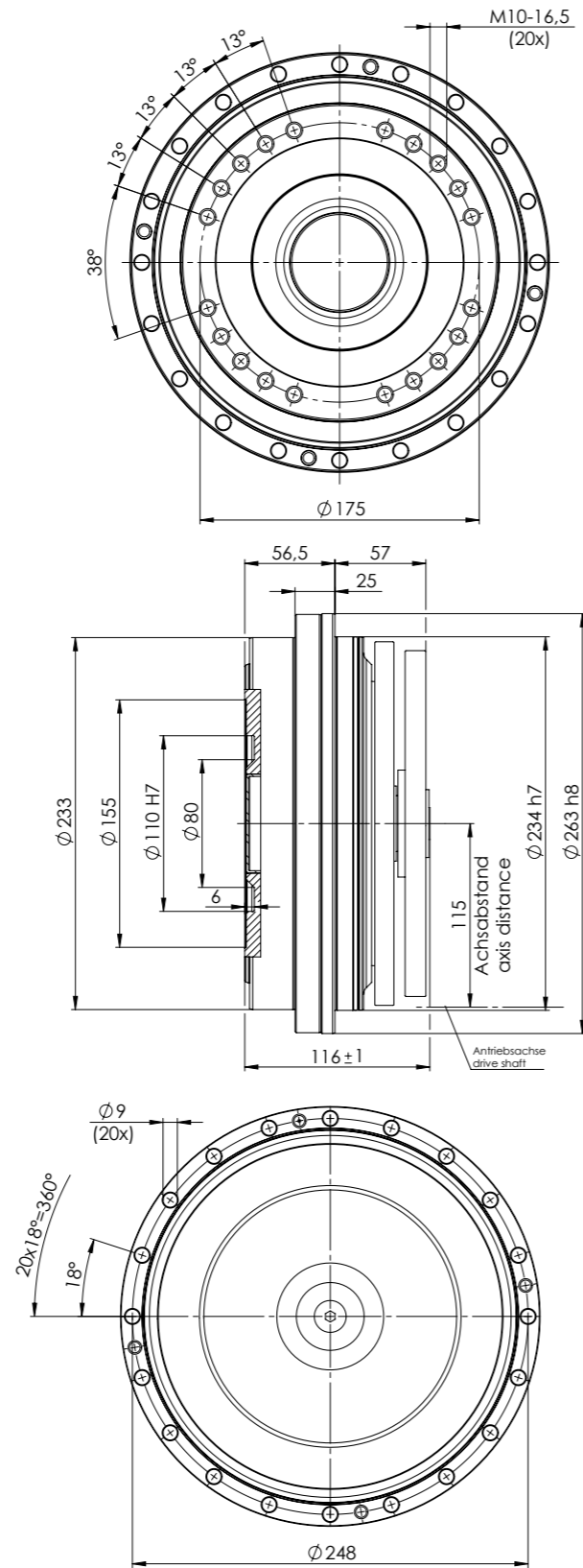

Gearbox size PSC300-V-E
(solid shaft, sub-assembly)

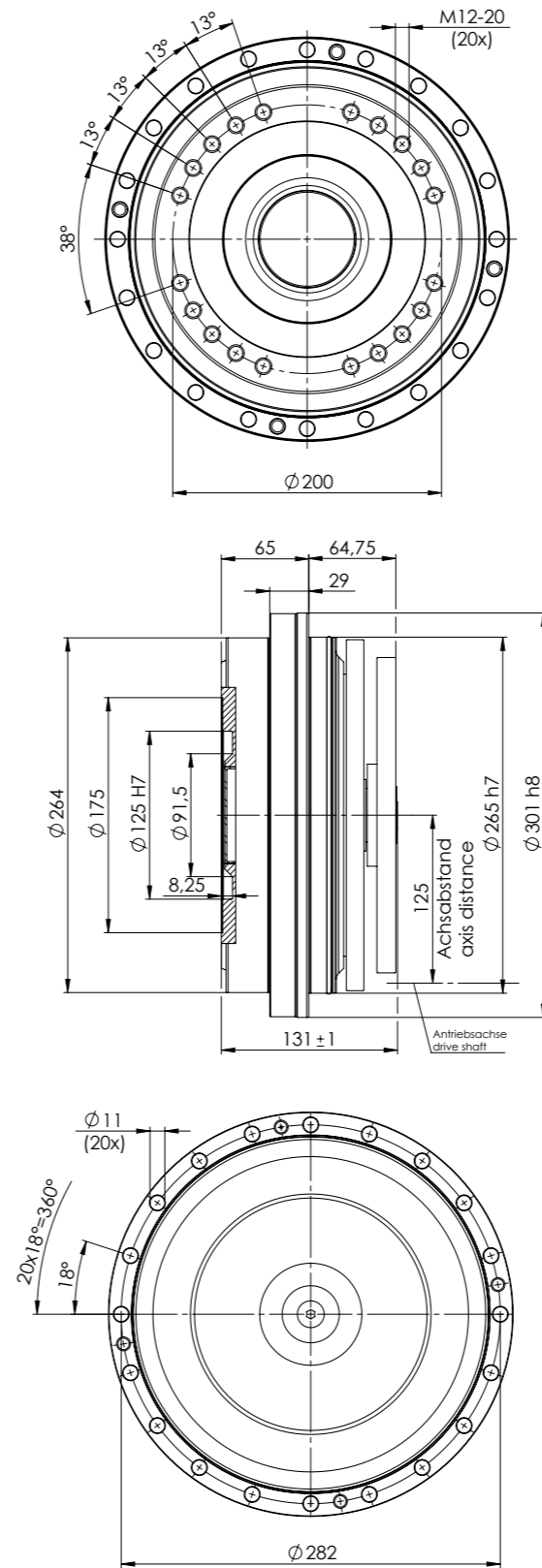

Gearbox size PSC400-V-E
(solid shaft, sub-assembly)

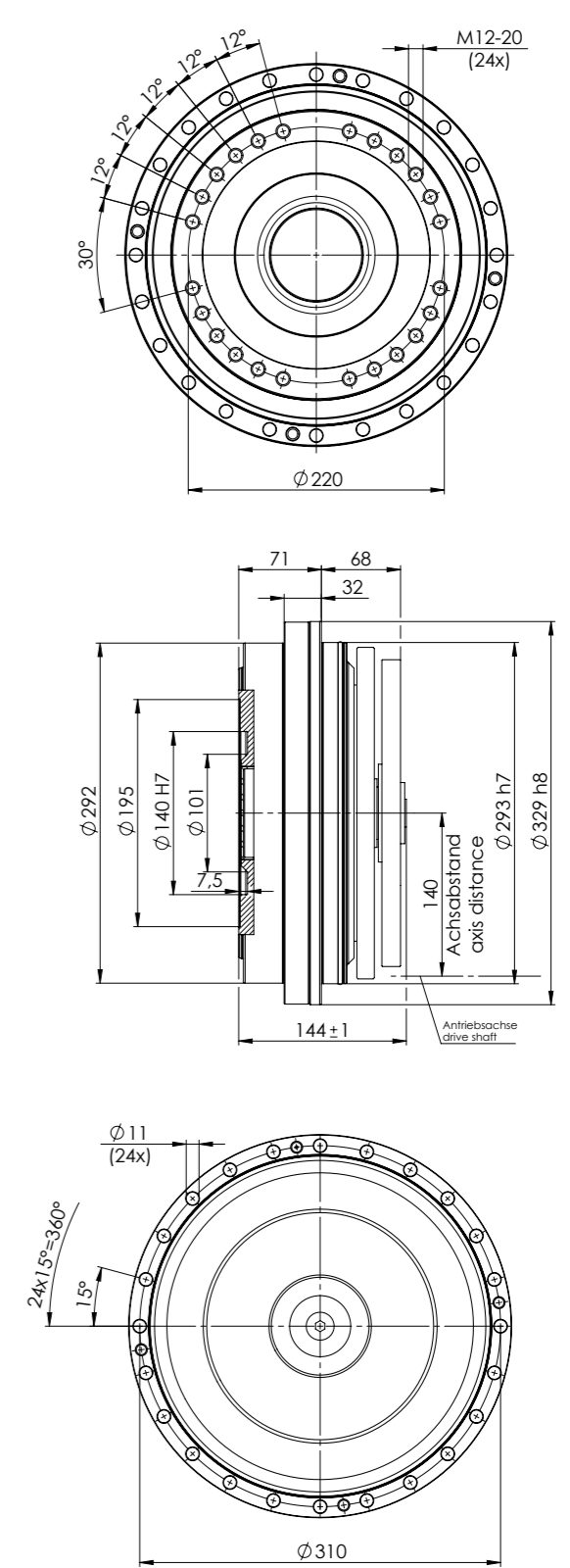

The dimensions of the output side also apply to the gear boxes.

The dimensions of the output side also apply to the gear boxes.

Gearbox size PSC057-H-E
(hollow shaft, sub-assembly)

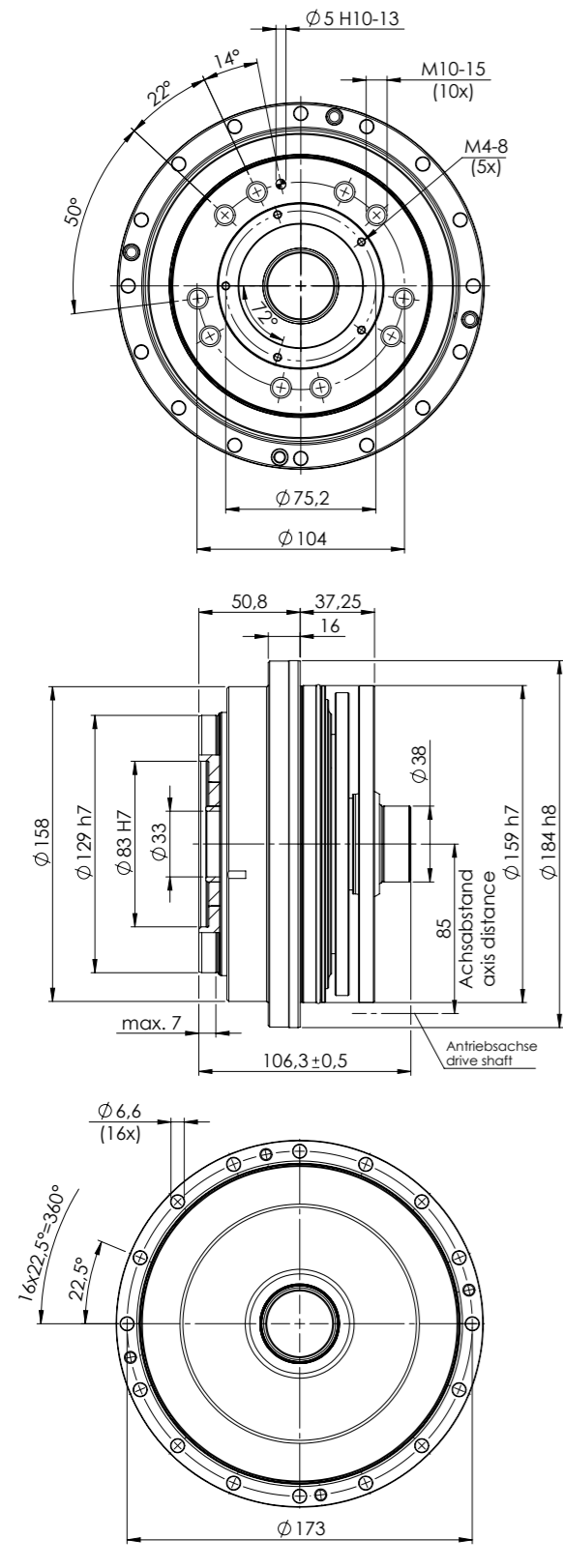

Gearbox size PSC080-H-E
(hollow shaft, sub-assembly)

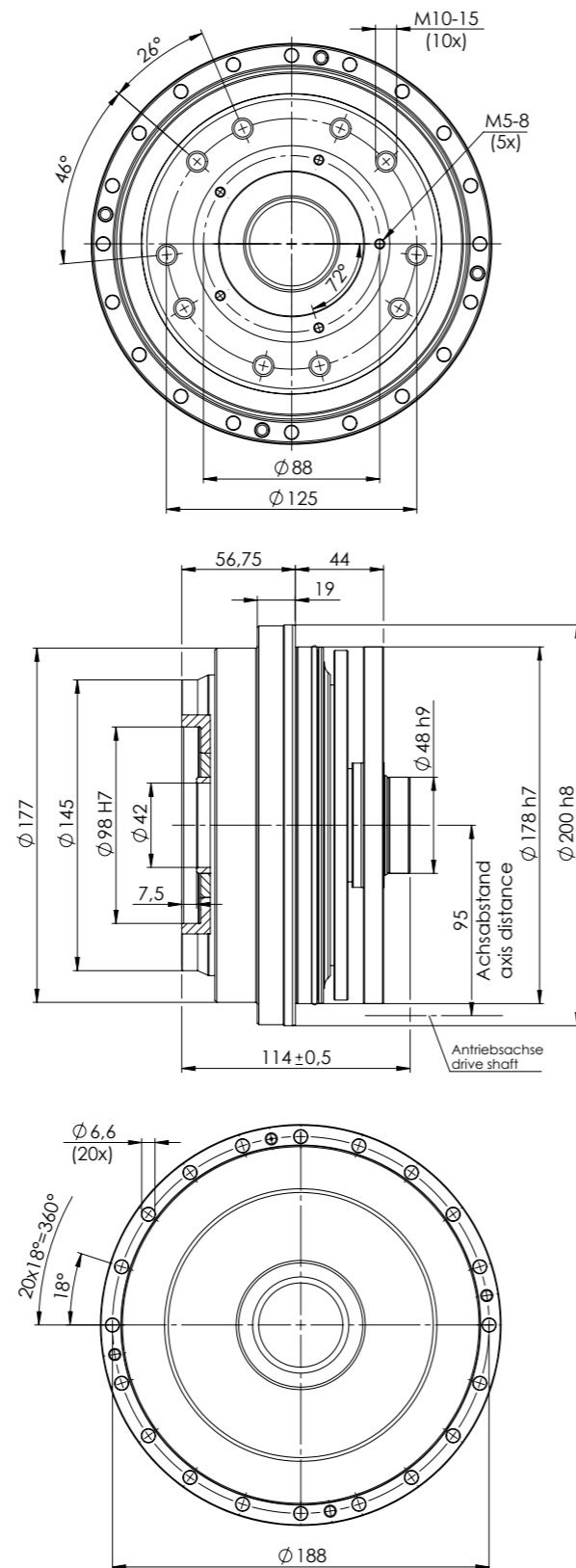

Gearbox size PSC112-H-E
(hollow shaft, sub-assembly)

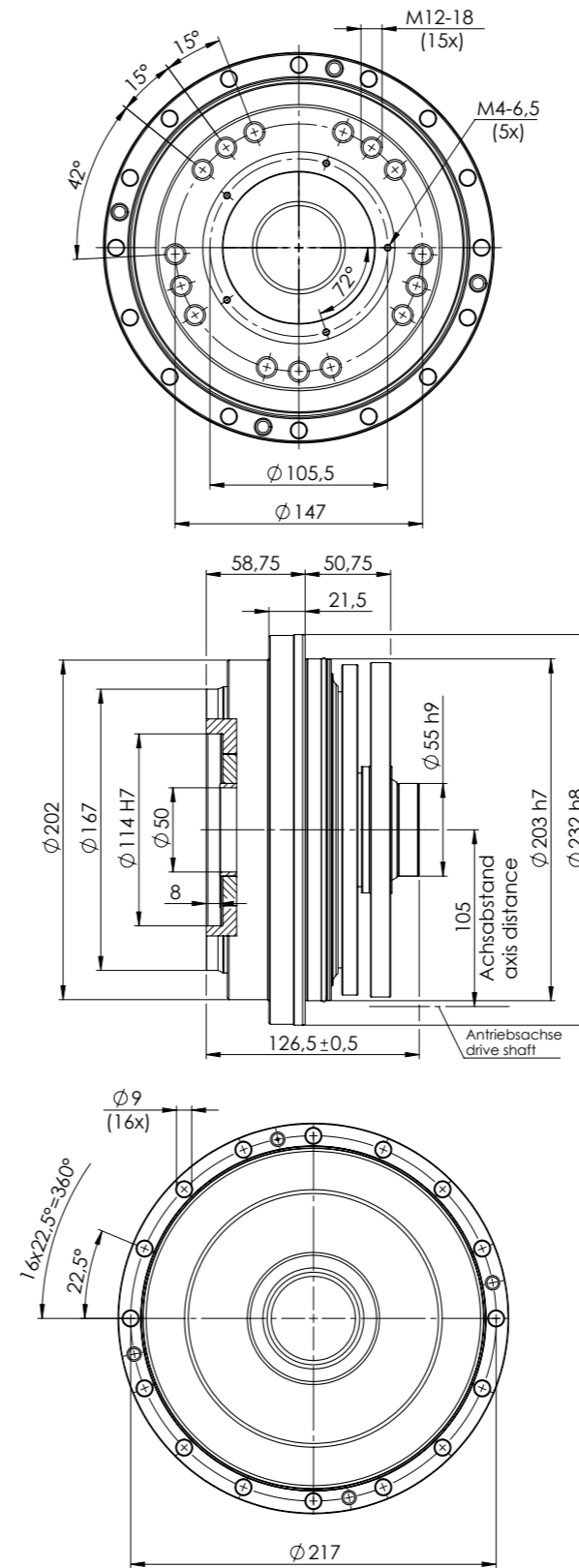

Gearbox size PSC160-H-E
(hollow shaft, sub-assembly)

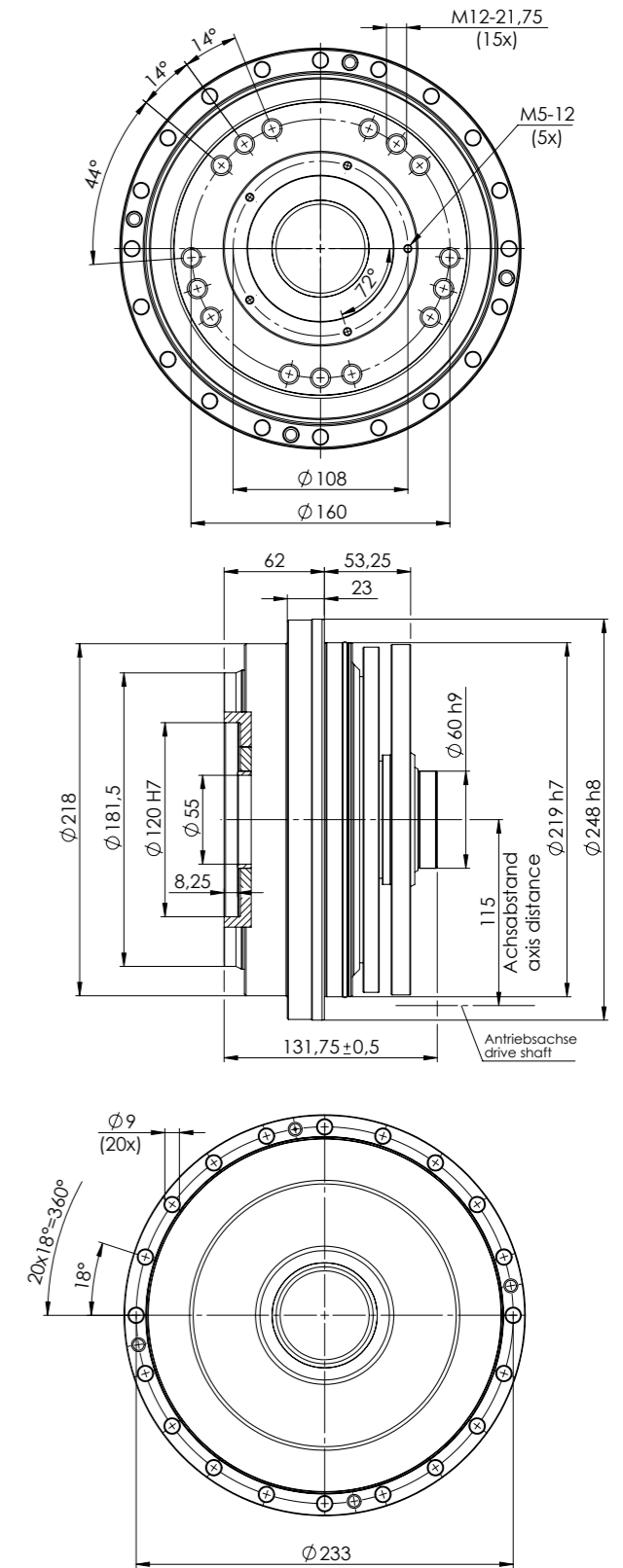

The dimensions of the output side also apply to the gear boxes.

Note: for the hollow shaft version we offer a protective sleeve on request. With a protective sleeve, the diameter of the hollow shaft is reduced to 29 mm for PSC057-H and to 38 mm for PSC080-H.

The dimensions of the output side also apply to the gear boxes.

Note: for the hollow shaft version we offer a protective sleeve on request. With a protective sleeve, the diameter of the hollow shaft is reduced to 46 mm for PSC112-H and 51 mm for PSC160-H.

Gearbox size PSC224-H-E
(hollow shaft, sub-assembly)

Gearbox size PSC300-H-E
(hollow shaft, sub-assembly)

Gearbox size PSC400-H-E
(hollow shaft, sub-assembly)

Gearbox size PSC500-H-E
(hollow shaft, sub-assembly)

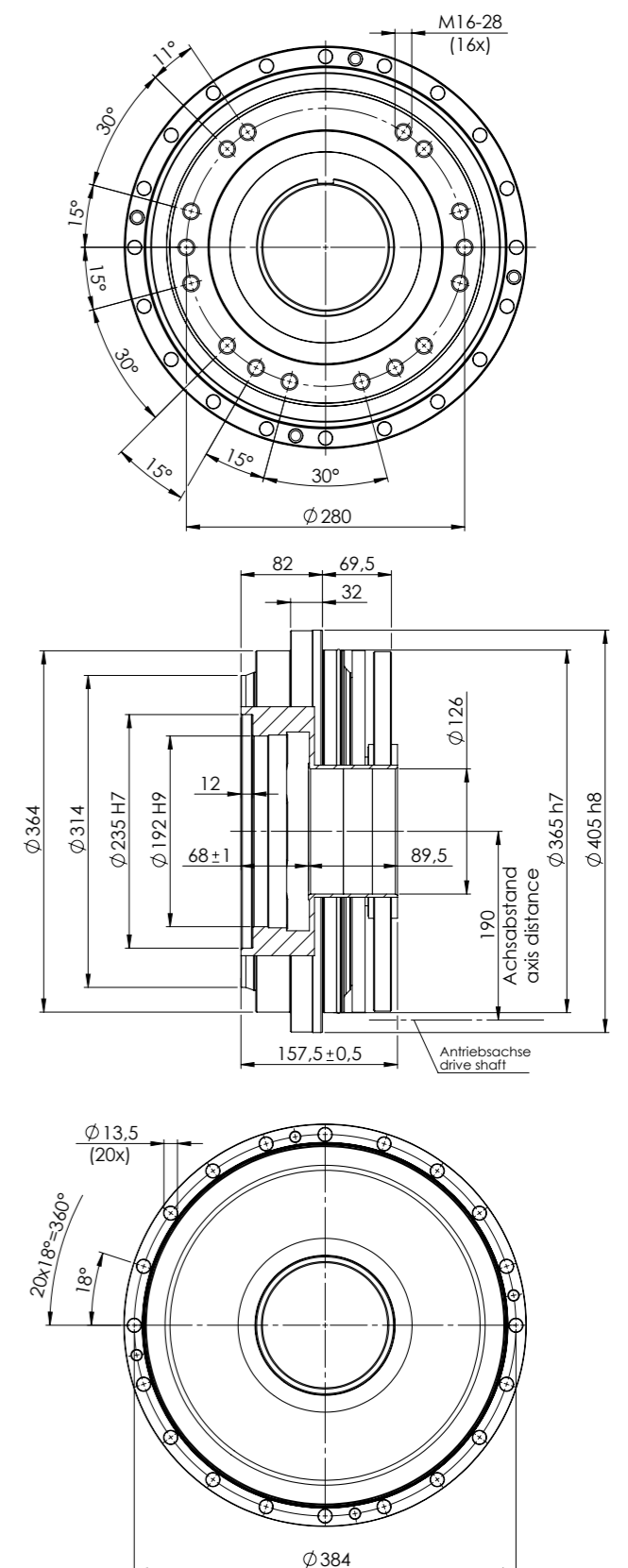
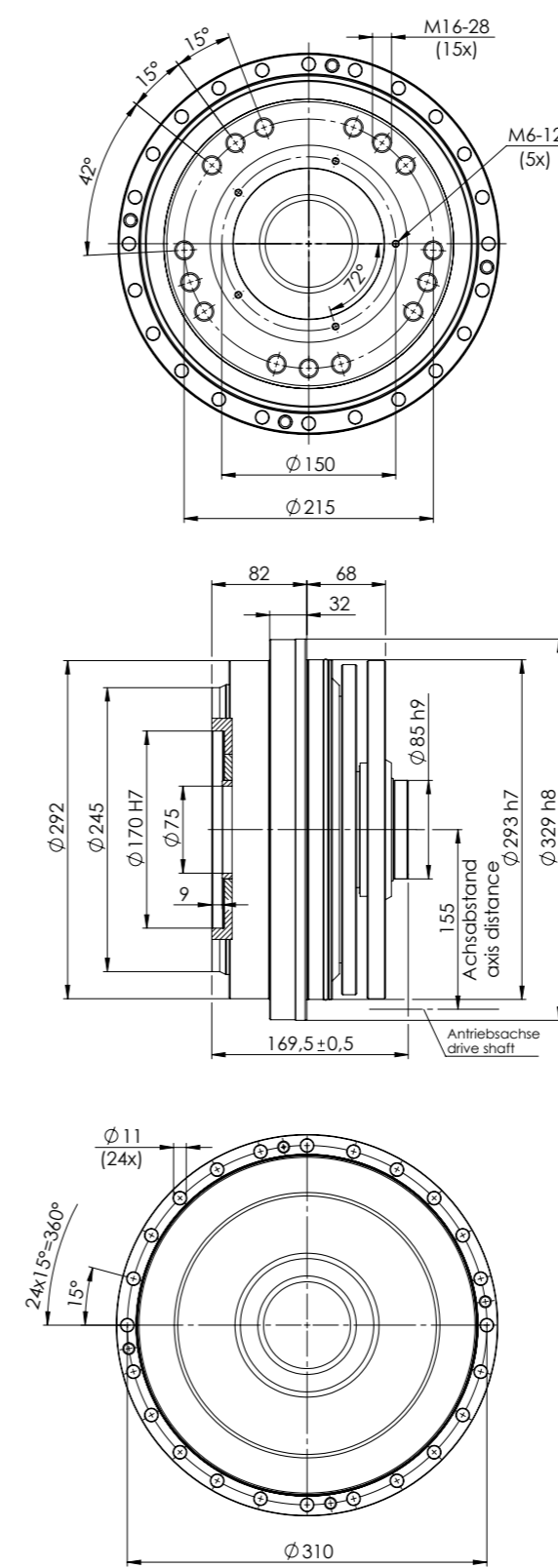
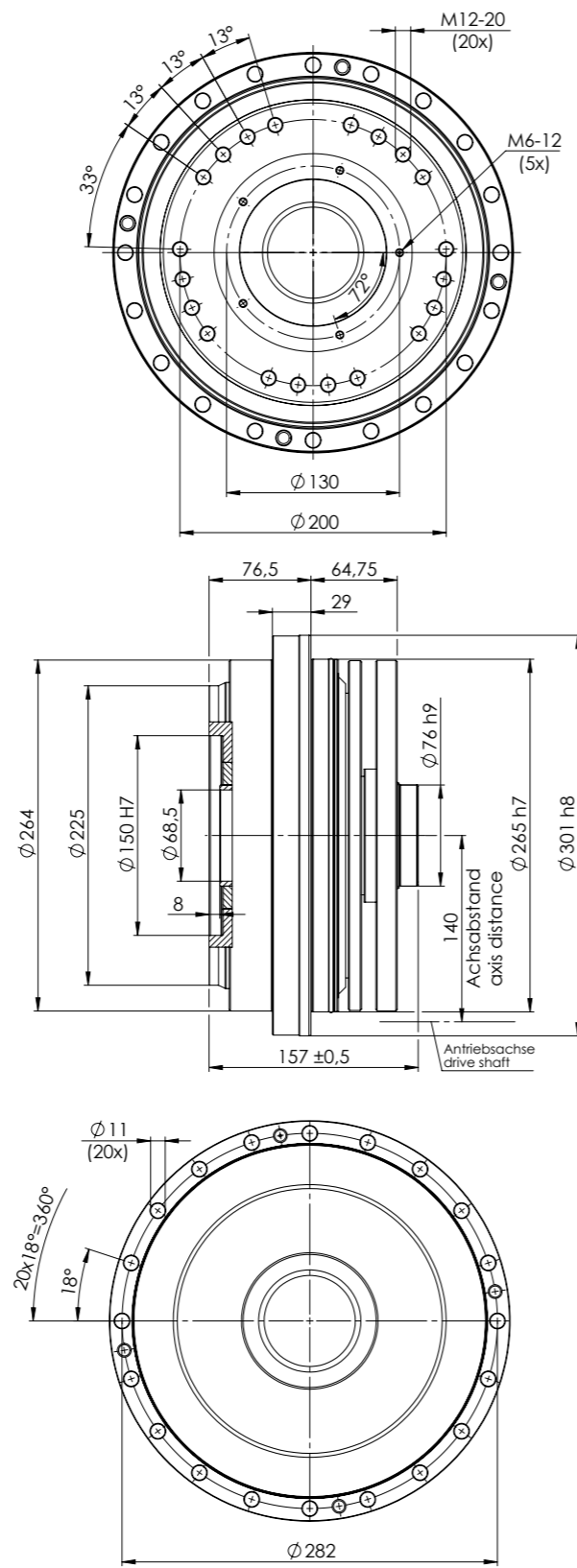
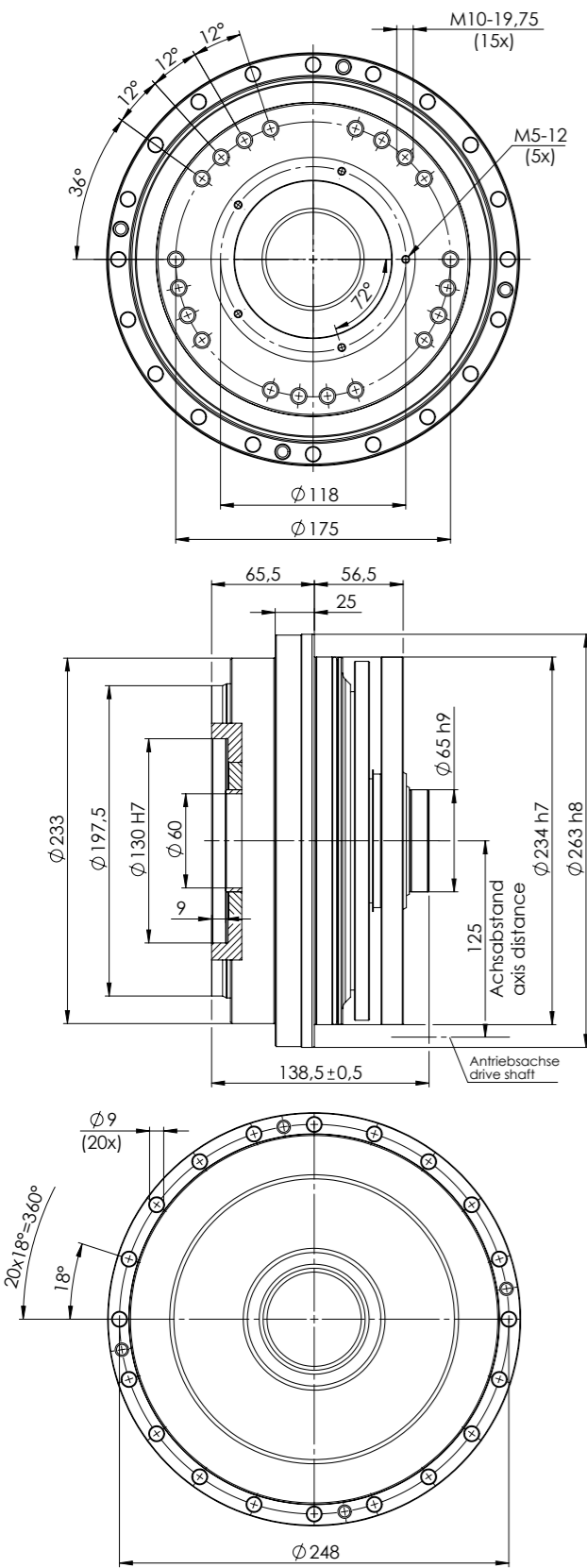

The dimensions of the output side also apply to the gear boxes.

Note: for the hollow shaft version we offer a protective sleeve on request. With a protective sleeve, the diameter of the hollow shaft PSC224-H is reduced to 56 mm and for PSC300-H to 64.5 mm.

The dimensions of the output side also apply to the gear boxes.

Note: for the hollow shaft version we offer a protective sleeve on request. With a protective sleeve, the diameter of the hollow shaft is reduced to 71 mm for PSC400-H and to 122 mm for PSC500-H.

PSC precision gears as two-stage sub-assembly

The sub-assemblies of the PSC gear unit series are also available in two-stage versions on request. In these cases, the sun pinion serves as the input pinion and can be adapted directly to the motor shaft so that the drive is centred.

For the PSC030 the sun pinion is designed as a plug-in pinion, for the other sizes PSC056 to PSC400 as a slip-on pinion. The available gear ratios can be found in the tables below.

With the exception of the input speeds, the other dimensions and performance data correspond to those of the standard sub-assemblies and gear units (page 22). In the case of two-stage mounting kits, the speeds are limited to the maximum output speeds specified therein.



Gearbox	i_{nenn}	i_{exakt}	$R \pm 0,25$	$\varnothing D4$	S
PSC030-V-E	20	4379/221	24.75	12 x6	30.00

Gearbox	i_{nenn}	i_{exakt}	$R \pm 0.25$	$\varnothing D5$	T
PSC056-V-E	14	6139/435	26.75	19 H6	11.50
PSC080-V-E	14	1508/105	29.25	22 H6	12.25
PSC112-V-E	14	6139/435	33.00	24 H6	14.00
PSC160-V-E	14	3169/225	36.25	28 H6	14.50
PSC224-V-E	14	99/7	38.50	28 H6	16.00
PSC300-V-E	14	3169/225	42.50	32 H6	18.00
PSC400-V-E	14	3169/225	47.75	38 H6	19.75

Gearbox	i_{nenn}	i_{exakt}	$R \pm 0,25$	$\varnothing D5$	T
PSC057-H-E-11	11	692/65	26.25	19 H6	13.00
PSC080-H-E-10	10	5858/611	28.25	24 H6	15.00
PSC112-H-E-9	9	223/25	33.50	28 H6	16.00
PSC160-H-E-9	9	2003/221	35.75	32 H6	18.00
PSC224-H-E-9	9	5587/637	37.00	32 H6	20.00
PSC300-H-E-9	9	2003/221	40.00	38 H6	20.00
PSC400-H-E-9	9	112/13	45.50	38 H6	28.00

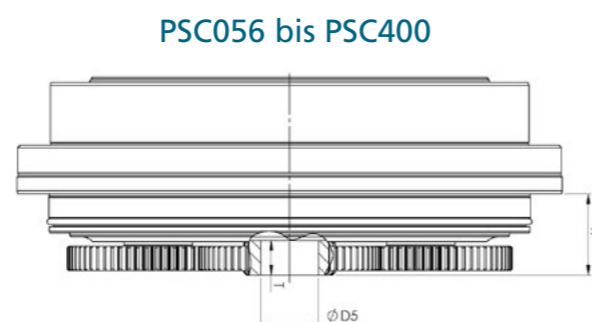
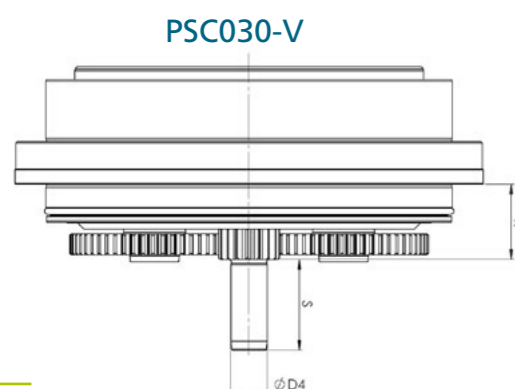

Plug-and-play

Our gear units are ideal for applications in which the customer's adjacent construction is to be designed with minimum effort.

The ready-to-install gear units are fully enclosed and easy to adapt to the motor. We can provide them with different motor mounting variants - including oil filling for immediate use.

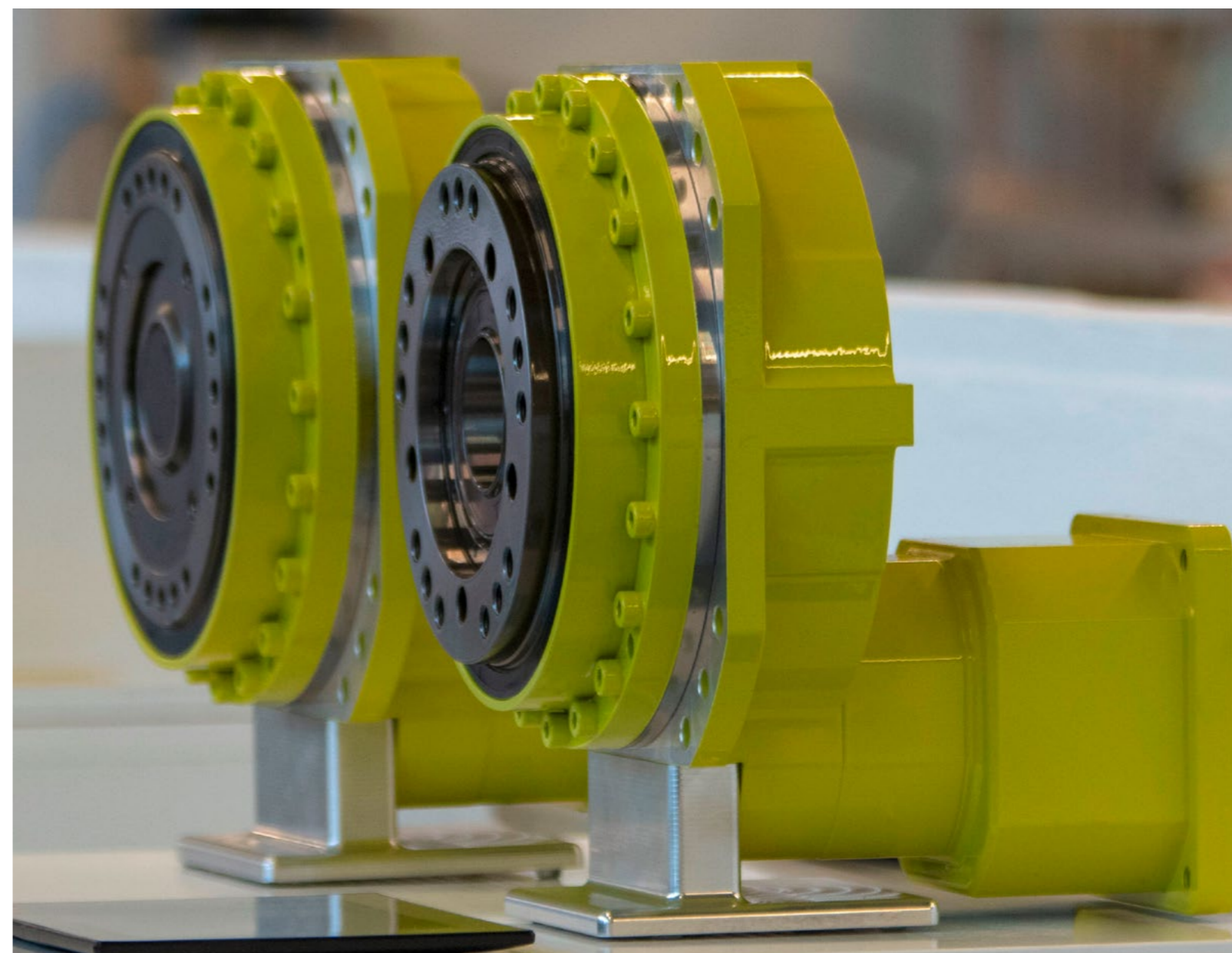

Motor mounting variant 0
with metal bellows coupling for a flexible and torsionally stiff connection of motor and gearbox for shaft diameters from 11 to 38 mm

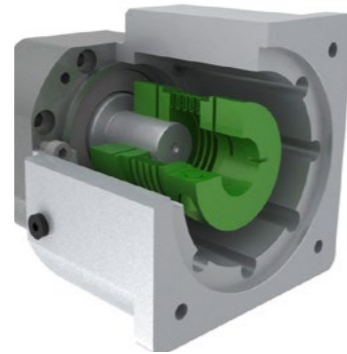

Motor mounting variant 1
with clamping hub for safe and compact torque transmission for smooth shafts from Ø11 to Ø32 mm



Motor mounting variant 2
Adapter with free drive shaft for individual connection design

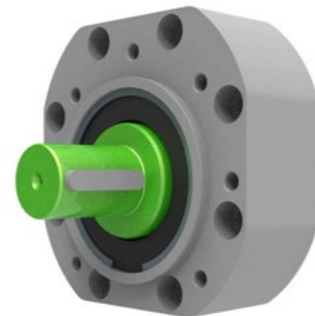

Motor mounting variant 6
with angle pre-stage

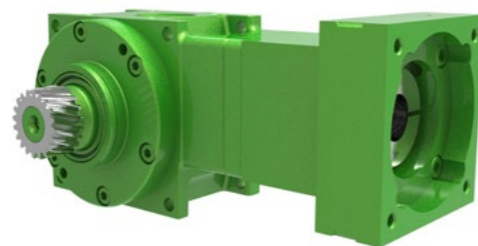

Gearboxes consist of a standard sub-assembly and are equipped with a flange cover and the desired adapter. The pinions (ER) or pinions (AR) shown are fitted with the desired adapter as standard.**

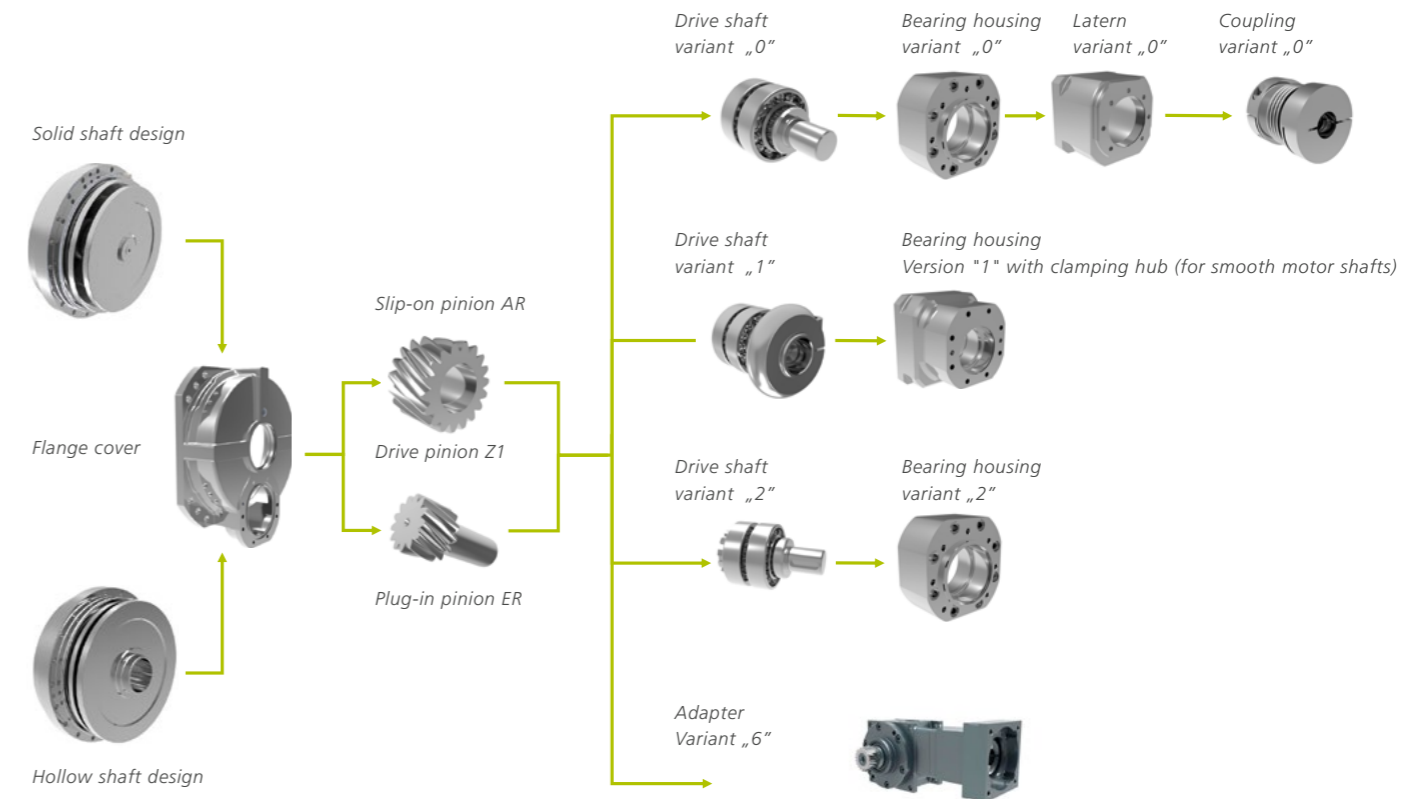

Dimension motor shaft d x l mm	Motor mounting variant	PSC030 PSC056 PSC057	PSC080	PSC112	PSC160	PSC224	PSC300	PSC400
11 x 23	0, 1,2	✓	✓					
14 x 30	0, 1,2	✓	✓					
16 x 40	0, 1,2	✓	✓	✓	✓	✓		
19 x 40	0, 1,2	✓	✓	✓	✓	✓		
22 x 50	0, 1,2	✓	✓	✓	✓	✓		
24 x 50	0, 1,2	✓	✓	✓	✓	✓		
28 x 60	0, 1,2	✓	✓	✓	✓	✓	✓	✓
32 x 60	0, 1,2	✓	✓	✓	✓	✓	✓	✓
35 x 60	0,2			✓	✓	✓	✓	✓
38 x 80	0,2			✓	✓	✓	✓	✓

Note: A smooth motor shaft must be assumed. Motor shafts with keyway are not recommended. Other motor shaft dimensions are available on request

** Whether a plug-in or slip-on pinion is used depends on the gear ratio.
For further information please refer to our operating instructions: www.meliormotion.com

PSC030-V

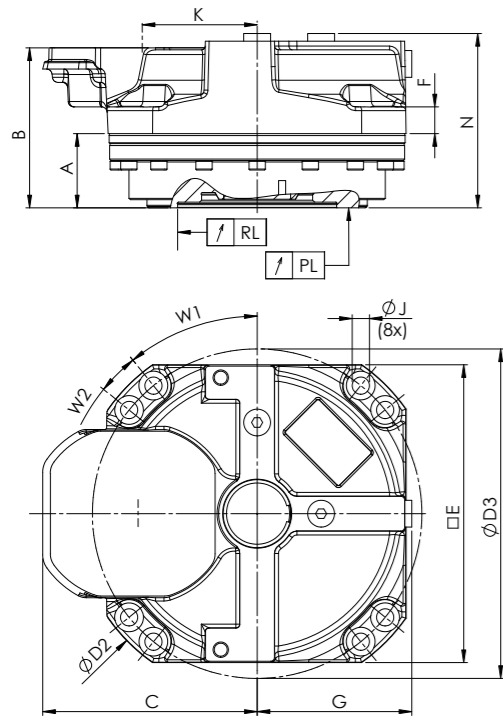

All gearboxes (except PSC030-V)

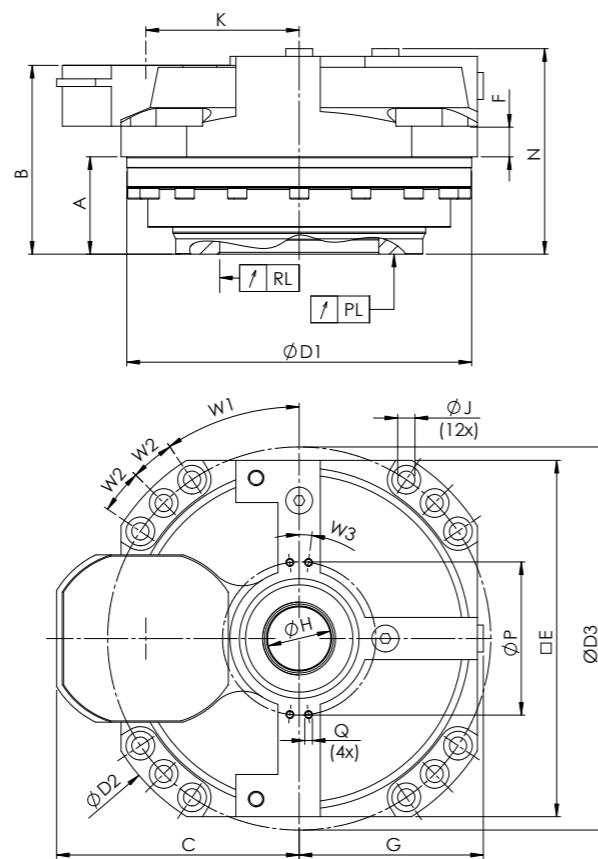

VARIANT 0 AND 1 -
0 = with coupling, 1 = with clamping hub

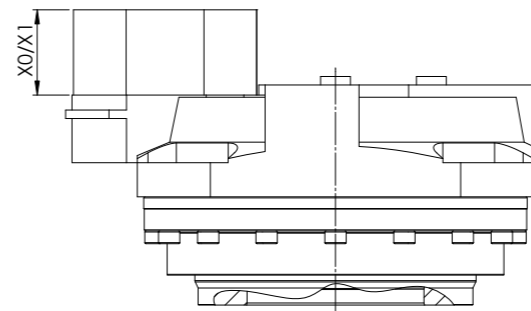

Gearbox	Length Motor shaft	X0	X1
	[mm]	[mm]	[mm]
PSC030	23	100	65.75
PSC056	30	107	70.750
PSC057	40	117	84.5
PSC080	50	127	95.5
PSC112	60	137	105.5
PSC160	40	132	85.25
PSC224	50	142	100.5
PSC224	60	152	110.5
PSC300/400	80	172	130.5
PSC300/400	60	163	111.5
PSC300/400	80	183	131.5

VARIANT 2 - with free input shaft

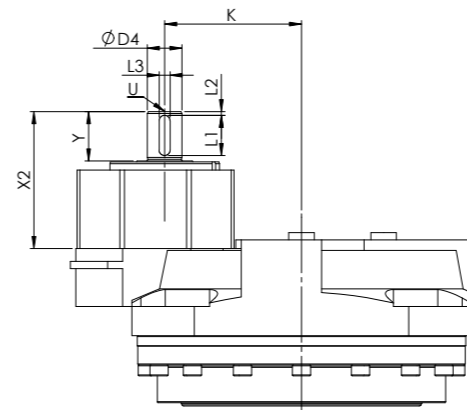

Gearbox	X2	Y	ØD4	L1	L2	L3	U
	[mm]	[mm]	[mm]	[mm]	[mm]	[mm]	[mm]
PSC030/056/057/080	75	27	19 k6	22	2	6 h9	M6
PSC112/160/224	90	35	24 k6	30	2	8 h9	M6
PSC300/400	100	45	30 k6	40	2	8 h9	M8

Gearbox with solid shaft

Gearbox	A [mm]	B [mm]	N [mm]	ØD1 [mm]	E [mm]	C [mm]	G [mm]	ØD2 [mm]	F [mm]	W1 [°]	W2 [°]	ØJ [mm]	ØD3 [mm]	K [mm]	RL [mm]	PL [mm]
PSC030-V	38.75	83.5	91	154.5 h8	156	112	81	190	13.5	39	12	9	172	60	0.029	0.032
PSC056-V	38.5	86.25	95	180 h8	186	127	96	220	15.5	34	11	9	200	75	0.029	0.035
PSC080-V	42.5	97.5	107.25	200 h8	202	137	105	240	18.5	34	11	9	220	85	0.029	0.035
PSC112-V	48.75	111.75	123.25	232 h8	234	158	121	282	21	34	11	11	255	95	0.032	0.035
PSC160-V	52	117.25	127.5	248 h8	254	168	131	296	22.5	32.5	12.5	11	272	105	0.032	0.039
PSC224-V	56.5	126.5	137	263 h8	272	178	140	317	24.5	32.5	12.5	13.5	286	115	0.032	0.039
PSC300-V	65	145.75	153.75	301 h8	303	200	156	360	28.5	32.5	12.5	13.5	329	125	0.035	0.039
PSC400-V	71	155	166	329 h8	335	215	172	390	31.5	32.5	12.5	13.5	357	140	0.035	0.039

Gearbox with hollow shaft

Gearbox	A [mm]	B [mm]	N [mm]	ØD1 [mm]	E [mm]	C [mm]	G [mm]	ØD2 [mm]	F [mm]	W1 [°]	W2 [°]	ØJ [mm]	ØD3 [mm]	K [mm]	H [mm]	P [mm]	W3 [°]	Q [-]	RL [mm]	PL [mm]
PSC057-H	50.8	98.55	107.3	184 h8	186	127	96	220	15.5	34	11	9	200	85	33	80	7	M4	0.032	0.035
PSC080-H	56.75	111.75	121.5	200 h8	202	137	105	240	18.5	34	11	9	220	95	42	90	6	M4	0.032	0.035
PSC112-H	58.75	121.75	133.25	232 h8	234	158	121	282	21	34	11	11	255	105	50	95	7	M5	0.032	0.035
PSC160-H	62	127.25	137.5	248 h8	254	168	131	296	22.5	32.5	12.5	11	272	115	55	115	6	M5	0.032	0.039
PSC224-H	65.5	135.5	146	263 h8	272	178	140	317	24.5	32.5	12.5	13.5	286	125	60	120	5.5	M5	0.035	0.039
PSC300-H	76.5	157.25	165.25	301 h8	303	200	156	360	28.5	32.5	12.5	13.5	329	140	68.5	130	7	M5	0.035	0.039
PSC400-H	82	166	177	329 h8	335	215	172	390	31.5	32.5	12.5	13.5	357	155	75	155	6	M6	0.035	0.039

VARIANT 6 -
with angle pre-stage

Solid shaft

Gearbox	X6 [mm]	K6 [mm]
PSC030-V-B	87.5	93.25
PSC056-V-B	87.5	96.25
PSC080-V-B	87.5	103.5
PSC112-V-B	94.5	114
PSC160-V-B	94.5	116.25
PSC224-V-B	107.5	129
PSC300-V-B	107.5	139.75
PSC400-V-B	129	155

Hollow shaft

Gearbox	X6 [mm]	K6 [mm]
PSC057-H-B	87.5	96.25
PSC080-H-B	87.5	103.5
PSC112-H-B	94.5	114
PSC160-H-B	107.5	124.25
PSC224-H-B	107.5	129
PSC300-H-B	129	151.75
PSC400-H-B	129	155

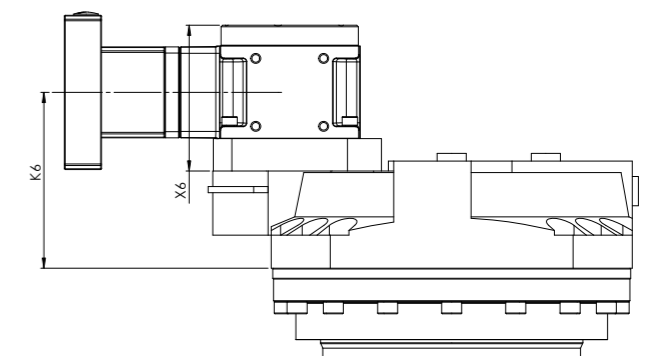

Here you can find the mass specifications of the fully enclosed gearboxes for version with free input shaft (version 2).

The mass data for the motor mounting variants 0 (with coupling) and 1 (with clamping hub) are dependent on the servo motor. Please consult us if required.

The weight specifications are exemplary for the weights indicated in the order code specified ratios. These may vary slightly for other ratios.

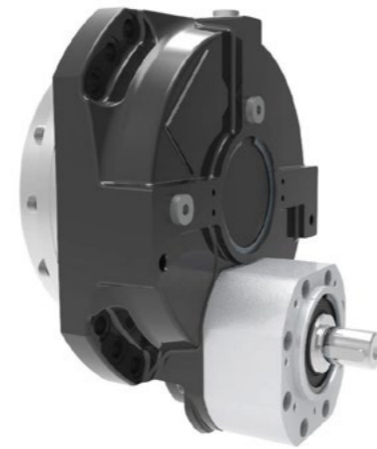

Gear units (variant 2)	Weight [kg]
PSC030-V-B-100-2-B50-F-0	9.58
PSC056-V-B-125-2-B50-F-0	13.77
PSC056-H-B-125-2-B50-F-0	14.13
PSC057-H-B-125-2-B50-F-0	14.36
PSC080-V-B-125-2-B50-F-0	18.15
PSC080-H-B-125-2-B50-F-0	18.85
PSC112-V-B-125-2-B50-F-0	28.24
PSC112-H-B-125-2-B50-F-0	28.68
PSC160-V-B-125-2-B50-F-0	33.72
PSC160-H-B-125-2-B50-F-0	34.45
PSC224-V-B-140-2-B50-F-0	40.62
PSC224-H-B-90-2-B50-F-0	40.75
PSC300-V-B-125-2-B50-F-0	59.63
PSC300-H-B-125-2-B50-F-0	60.08
PSC400-V-B-112-2-B50-F-0	77.03
PSC400-H-B-125-2-B50-F-0	77.9

Output on bottom, input on top

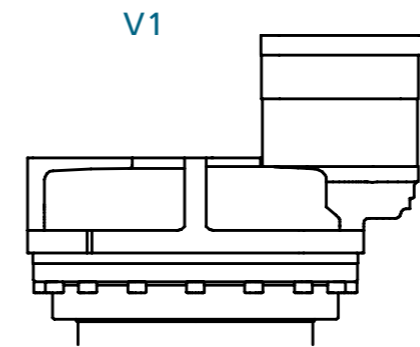

Output on top, input on bottom

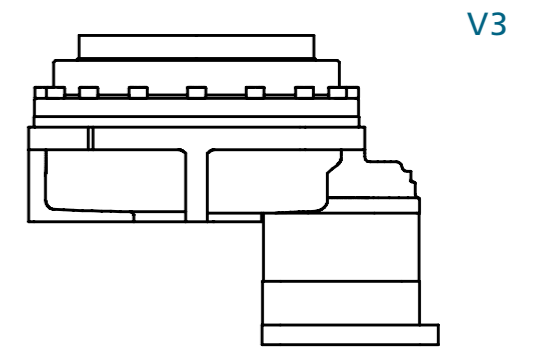

Input horizontal, Entry position optional

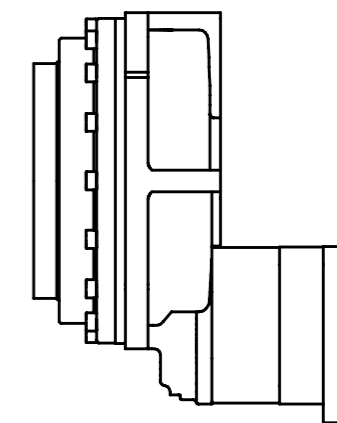
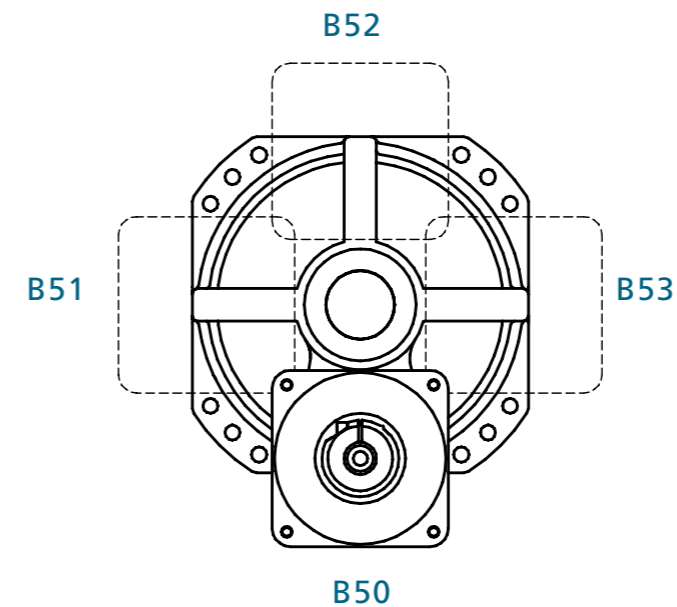



If little space is available, the variant with right angle pre-stage is the best choice.

Due to different ratios of the right angle pre-stage a wide range of total gear ratios can be realised.

A selection can be found in the following table.

Design with **solid shaft**

Gearbox	Nominal ratio	Exact ratio	Emergency stop torque	Gearbox	Nominal ratio	Exact ratio	Emergency stop torque
PSC030-V	150	337183/2210	800	PSC160-V	150	354928/2325	3,562
PSC030-V	189	1077234/5525	800	PSC160-V	189	9507/50	4,437
PSC030-V	240	376594/1547	800	PSC160-V	240	386618/1575	4,800
PSC030-V	315	359078/1105	800	PSC160-V	315	3169/10	4,437
PSC030-V	400	1882970/4641	800	PSC160-V	400	386618/945	4,800
PSC030-V	504	2872624/5525	800	PSC160-V	504	25352/50	4,437
PSC030-V	640	3012752/4641	800	PSC160-V	640	3092944/4725	4,800
PSC056-V	150	564788/3915	1,545	PSC224-V	150	10593/70	6,090
PSC056-V	189	85946/435	1,545	PSC224-V	189	4752/25	6,090
PSC056-V	250	564788/2349	1,545	PSC224-V	240	11484/49	6,090
PSC056-V	315	85946/261	1,545	PSC224-V	315	1584/5	6,090
PSC056-V	400	4518304/11745	1,545	PSC224-V	400	19140/49	6,090
PSC056-V	504	687568/1305	1,545	PSC224-V	504	12672/25	6,090
PSC056-V	630	171892/261	1,545	PSC224-V	640	30624/49	6,090
PSC080-V	150	754/5	2,212	PSC300-V	150	19014/125	7,099
PSC080-V	189	33176/175	2,530	PSC300-V	189	358097/1875	8,913
PSC080-V	240	57304/245	2,530	PSC300-V	240	186971/750	8,990
PSC080-V	315	33176/105	2,530	PSC300-V	315	358097/1125	8,913
PSC080-V	400	57304/147	2,530	PSC300-V	400	186971/450	8,990
PSC080-V	504	265408/525	2,530	PSC300-V	504	2864776/5625	8,913
PSC080-V	640	458432/735	2,530	PSC300-V	640	1495768/2250	8,990
PSC112-V	150	325367/2175	3,491	PSC400-V	150	354928/2325	11,980
PSC112-V	189	681429/3625	3,780	PSC400-V	189	9507/50	11,980
PSC112-V	240	6139/25	3,780	PSC400-V	240	34859/150	11,980
PSC112-V	315	227143/725	3,780	PSC400-V	315	3169/10	11,980
PSC112-V	400	6139/15	3,780	PSC400-V	400	34859/90	11,980
PSC112-V	504	1817144/3625	3,780	PSC400-V	504	25352/50	11,980
PSC112-V	640	49112/75	3,780	PSC400-V	640	278872/450	11,980

All other values like sub-assemblies or gear units

Other ratios on request

For the most common input variants with angular pre-stage you will find the gear ratios here. Do you require different gear ratios? Then ask us - we will be happy to help you.

Design with **hollow shaft**

Gearbox	Nominal ratio	Exact ratio	Emergency stop torque	Gearbox	Nominal ratio	Exact ratio	Emergency stop torque
PSC057-H	106.5	7266/65	1,545	PSC224-H	106.5	206719/1911	5,048
PSC057-H	135	45672/325	1,545	PSC224-H	135	972138/7007	6,090
PSC057-H	168	78888/455	1,545	PSC224-H	177.5	1033595/5733	5,048
PSC057-H	225	15224/65	1,545	PSC224-H	225	1620230/7007	6,090
PSC057-H	280	26296/91	1,545	PSC224-H	284	1653752/5733	5,048
PSC057-H	360	121792/325	1,545	PSC224-H	360	2592368/7007	6,090
PSC057-H	448	210368/455	1,545	PSC224-H	450	3240460/7007	6,090
PSC057-H	560	52592/91	1,545	PSC300-H	106.5	685026/6409	8,990
PSC080-H	106.5	64842/611	1,556	PSC300-H	135	14021/104	8,990
PSC080-H	135	82012/611	1,969	PSC300-H	168	739107/4420	8,990
PSC080-H	168	509646/3055	2,447	PSC300-H	225	70105/312	8,990
PSC080-H	225	410060/1833	1,969	PSC300-H	280	246369/884	8,990
PSC080-H	280	169882/611	2,447	PSC300-H	360	14021/39	8,990
PSC080-H	360	656096/1833	1,969	PSC300-H	448	492738/1105	8,990
PSC080-H	448	1359056/3055	2,447	PSC300-H	560	246369/442	8,990
PSC080-H	560	339764/611	2,447	PSC400-H	106.5	12544/117	10,007
PSC112-H	106.5	76266/725	2,455	PSC400-H	135	1512/11	11,980
PSC112-H	135	26537/200	3,096	PSC400-H	168	40320/247	11,980
PSC112-H	168	82287/500	3,780	PSC400-H	225	2520/11	11,980
PSC112-H	225	26537/120	3,096	PSC400-H	280	67200/247	11,980
PSC112-H	280	27429/100	3,780	PSC400-H	360	4032/11	11,980
PSC112-H	360	53074/150	3,096	PSC400-H	448	107520/247	11,980
PSC112-H	448	54858/125	3,780	PSC400-H	560	134400/247	11,980
PSC112-H	560	27429/50	3,780				
PSC160-H	106.5	654981/6188	4,800				
PSC160-H	135	685026/5083	4,800				
PSC160-H	177.5	1091635/6188	4,800				
PSC160-H	225	1141710/5083	4,800				
PSC160-H	284	436654/1547	4,800				
PSC160-H	360	1826736/5083	4,800				
PSC160-H	450	2283420/5083	4,800				

Mounting positions for variant 6 with right angle pre-stage

The mounting positions of the right angle pre-stages are sketched below, while those of the main gear unit are shown on page 37.

The mounting position of the right angle pre-stage is to be understood relative to the main gear unit.

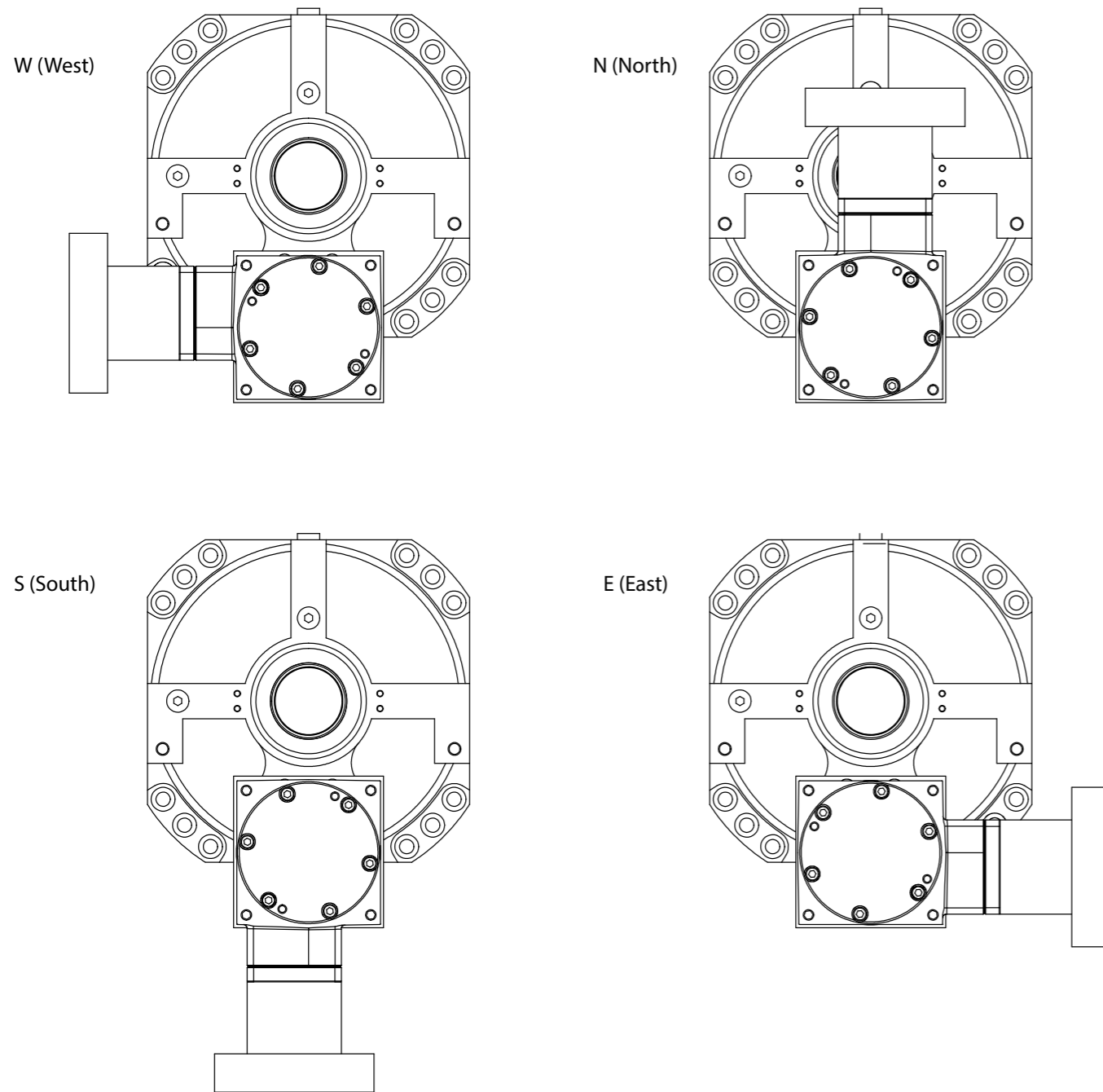

Variants for the output

For the output there are mainly three possible variants.

In addition to the standard output flange (without further attachments), pinions can also be mounted on the output side, for example for rack and pinion applications. Alternatively, additional Output shafts are possible. We will be pleased to offer you further options on request.

Output variants

Here are some examples:



Output flange

Standard: Housing stands, Output flange rotates

Option: housing rotates, Output flange stands

Further possibilities on request

Melior Motion offers gear units specially adapted to customer requirements for a variety of applications. From completely new developments to optimizations and modifications to existing series, we develop and manufacture precision gears, consisting of planetary, helical or bevel gear stages, according to customer requirements.

Some examples are given below:

SP191 – 2-Axis Robotic gearbox

Dimensions:	customer specific
Hollow shaft:	80 mm
Backlash:	≤ 0,1 arcmin
Ratio:	100 / 130:1
Torque:	Mmax = 2000 Nm



SP244 - Linear axis gearbox

Dimensions:	customer specific
Backlash:	< 4 arcmin
Ratio:	10:1
Torque:	Mmax = 800 Nm
Special feature:	output side with pinion for Rack and pinion application



SP224 - Positioning drive

Dimensions:	customer specific
Backlash:	< 0.1 arcmin
Ratio:	up to 130:1
Hollow shaft:	up to 95 mm diameter
positioning accuracy:	+/- 0.03 mm



	PSC	112	H	E	100	1	V1	F	0
Gearbox series (PSC)									
Sizes (030 ... 500)									
Execution:	V = solid shaft H = hollow shaft								
Type:	E = gearbox sub-assembly B = fully enclosed gearbox with flange S = others								
Ratios: (35.5 ... 200)									
Input:	0 = Coupling 4 = Sub-assembly with Z1 input pinion 1 = Clamping hub* 5 = Integral motor 2 = Free input shaft with keyway 6 = Angle pre-stage 3 = Free input shaft without keyway 7 = Helical pre-stage 8 = Splined shaft 9 = Others								
Mounting position: (V1, V3, ...) see page 37									
Output:	F = flange (standard) R = pinion on output (to specify) W = shaft end (to specify) S = special (to specify)								
Others: (0,1,2) 0 = standard 1 = special (to be specified) 2 = with hollow shaft sleeve									

For motor connection please attach motor data sheet.

Lubrication

sub-assemblies: Delivery without oil filling | Gear units: mineral oil Castrol Optigear EP 320 PD

Painting

Standard: not painted

* only suitable for smooth motor shafts



Melior Motion GmbH

Ohsener Str. 79–83

31789 Hameln

Germany

Tel. +49 5151 9113000

E-Mail: info@meliormotion.com

www.meliormotion.com



www.meliormotion.com

