

### Technical data

The following lamina types are to be distinguished with RADEX®-N:

Size 20 – 50  
(lamina with 4 holes)

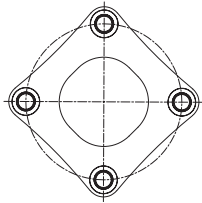

Size 60 – 135  
(lamina with 6 holes)

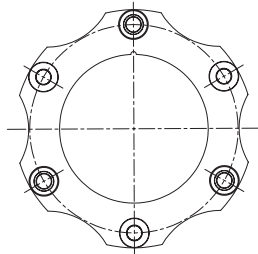

Size 136 – 336  
(lamina with 6 holes)

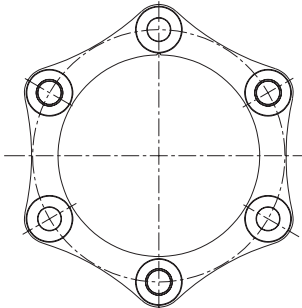

Size 138 – 338  
(lamina with 8 holes)

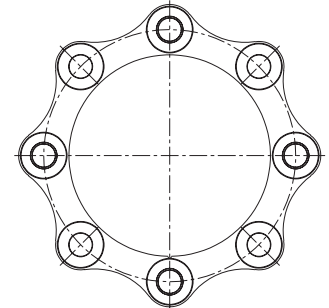

### Torques and displacements

Size	Lamina shape	Torques [Nm] <sup>1)</sup>			Angular [°] each lamina	Perm. displacements <sup>2)</sup>			
		TKN	TK max	TKW		Axial [mm]		Radial [mm]	
						NN	NANA 1/ NANA2/ NNZ	NANA 1	NANA 2/NNZ
20		30	60	15	1.0	0.60	1.2	1.0	0.2
25		60	120	30	1.0	0.80	1.6	1.0	0.2
35	lamina with 4 holes	120	240	60	1.0	1.00	2.0	1.1	0.3
38		240	480	120	1.0	1.20	2.4	1.2	0.3
42		320	640	160	1.0	1.40	2.8	1.2	0.4
50		470	940	235	1.0	1.60	3.2	1.5	0.4
60		900	1800	450	1.0	1.00	2.0	1.5	0.8
70		1300	2600	650	1.0	1.10	2.2	1.8	1.0
80		1800	3600	900	1.0	1.30	2.6	2.1	1.2
85		2600	5200	1300	1.0	1.30	2.6	2.2	1.2
90		4600	9200	2300	1.0	1.00	2.0	2.2	1.1
105		5600	11200	2800	1.0	1.20	2.4	2.4	1.4
115		9900	19800	4950	1.0	1.40	2.8	2.5	1.5
135	lamina with 6 holes	13500	27000	6750	1.0	1.75	3.5	3.8	–
136		17500	35000	8750	0.7	1.85	3.7		
156		25000	50000	12500	0.7	2.10	4.2		
166		35000	70000	17500	0.7	2.25	4.5		
186		42000	84000	21000	0.7	2.40	4.8		
206		52500	105000	26250	0.7	2.60	5.2		
246		90000	180000	45000	0.7	3.00	6.0		
286		150000	300000	75000	0.7	3.35	6.7		
336		210000	420000	105000	0.7	3.75	7.5		
138		23000	46000	11500	0.5	1.30	2.6	Depending on shaft distance dimension E	
158	33000	66000	16500	0.5	1.40	2.8			
168	45000	90000	22500	0.5	1.50	3.0			
188	56000	112000	28000	0.5	1.60	3.2			
208	70000	140000	35000	0.5	1.75	3.5			
248	120000	240000	60000	0.5	2.00	4.0			
288	200000	400000	100000	0.5	2.40	4.5			
338	280000	560000	140000	0.5	2.50	5.0			

<sup>1)</sup> = Years of experience with applications at customer sites and additional test series in the KTR test field in Rheine enabled us to determine potentials allowing for an increase of the rated and maximum torques with some sizes of this series.

### Permissible speeds and torsional stiffness figures

Size	Max. speed [rpm] (higher speeds on request)	Torsion spring stiffness x 10 <sup>6</sup> [Nm/rad] per lamina set	Size	Max. speed [rpm] (higher speeds on request)	Torsion spring stiffness x 10 <sup>6</sup> [Nm/rad] per lamina set
20	20400	0.02	156	3500	17.00
25	16800	0.03	166	3300	19.00
35	13900	0.11	186	3000	25.00
38	12000	0.20	206	2800	31.00
42	11000	0.28	246	2300	55.00
50	9000	0.50	286	2000	79.00
60	8200	0.56	336	1800	125.00
70	7300	0.90	138	3800	20.00
80	6300	1.10	158	3500	26.00
85	5900	1.50	168	3300	30.00
90	5400	2.00	188	3000	39.00
105	5000	2.50	208	2800	49.00
115	4300	3.50	248	2300	83.00
135	3700	6.90	288	2000	125.00
136	3800	13.00	338	1800	200.00

<sup>1)</sup> For selection of coupling see page 18 et seqq.

<sup>2)</sup> The permissible displacement figures specified are maximum figures which must not arise simultaneously. If radial, axial and angular displacements arise in parallel, the figures need to be reduced.

### Technical data

Weights and mass moments of inertia						
Size	Hub <sup>1)</sup> [kg] / [kgm <sup>2</sup> ]	Lamina set [kg] / [kgm <sup>2</sup> ]	NN <sup>1)</sup> complete [kg] / [kgm <sup>2</sup> ]	NANA 1 <sup>1)</sup> complete [kg] / [kgm <sup>2</sup> ]	NANA 2 <sup>1)</sup> complete [kg] / [kgm <sup>2</sup> ]	NNZ <sup>1)</sup> complete [kg] / [kgm <sup>2</sup> ]
20	0.13 / 0.000043	0.04 / 0.00002	0.3 / 0.00011	0.6 / 0.000204	-	0.4 / 0.000166
25	0.2 / 0.000116	0.08 / 0.00005	0.56 / 0.00028	0.9 / 0.000522	-	0.8 / 0.000414
35	0.6 / 0.00042	0.10 / 0.00010	1.2 / 0.00094	1.9 / 0.00158	-	1.6 / 0.00129
38	0.8 / 0.00073	0.20 / 0.00026	1.8 / 0.0017	2.8 / 0.00303	-	2.4 / 0.00247
42	1.1 / 0.00123	0.25 / 0.00040	2.4 / 0.0029	3.6 / 0.00482	-	3.1 / 0.00409
50	1.7 / 0.00291	0.46 / 0.0010	4.0 / 0.0068	6.2 / 0.0118	-	5.1 / 0.00932
60	1.9 / 0.00378	0.40 / 0.0012	4.2 / 0.0087	6.0 / 0.0141	5.8 / 0.0138	5.3 / 0.0120
70	2.8 / 0.00714	0.42 / 0.0016	6.0 / 0.016	8.6 / 0.0253	8.2 / 0.0242	7.5 / 0.0214
80	4.1 / 0.0134	0.72 / 0.0037	9.0 / 0.031	12.6 / 0.0476	12.0 / 0.0458	11.1 / 0.0410
85	5.1 / 0.0195	1.0 / 0.0065	11.2 / 0.046	16.2 / 0.0734	15.5 / 0.0711	14.8 / 0.0650
90	6.2 / 0.0282	2.3 / 0.0162	14.7 / 0.073	22.0 / 0.121	21.3 / 0.119	20.1 / 0.108
105	7.6 / 0.0414	2.2 / 0.0180	17.4 / 0.101	25.8 / 0.165	24.6 / 0.159	23.1 / 0.145
115	12.0 / 0.0899	4.0 / 0.0433	27.9 / 0.223	42.8 / 0.381	41.2 / 0.372	38.3 / 0.333
135	19.0 / 0.187	7.3 / 0.105	45.1 / 0.478	71.3 / 0.835	-	-
136	16.8 / 0.153	7.9 / 0.113	41.4 / 0.419	-	-	-
156	20.2 / 0.217	11.9 / 0.200	52.2 / 0.634	-	-	-
166	30.0 / 0.373	12.3 / 0.255	72.3 / 1.001	-	-	-
186	42.0 / 0.629	12.7 / 0.318	96.7 / 1.576	-	-	-
206	55.1 / 1.004	18.2 / 0.548	128.3 / 2.556	-	-	-
246	85.9 / 2.229	31.2 / 1.304	203.1 / 5.762	-	-	-
286	145.1 / 4.977	44.4 / 2.495	334.4 / 12.449	-	-	-
336	223.9 / 10.486	64.2 / 4.74	512.0 / 25.712	-	-	-
138	16.2 / 0.145	9.9 / 0.143	42.3 / 0.433	Depending on shaft distance dimension E	Depending on shaft distance dimension E	-
158	19.5 / 0.205	14.9 / 0.252	54.0 / 0.662	-	-	-
168	29.4 / 0.360	15.2 / 0.318	74.0 / 1.038	-	-	-
188	41.7 / 0.611	15.6 / 0.396	99.0 / 1.618	-	-	-
208	54.1 / 0.971	22.4 / 0.680	130.5 / 2.622	-	-	-
248	84.0 / 2.144	38.2 / 1.605	206.2 / 5.893	-	-	-
288	142.5 / 4.823	53.8 / 3.056	338.8 / 12.702	-	-	-
338	220.1 / 10.18	78.0 / 5.817	518.2 / 26.177	-	-	-

<sup>1)</sup> Hubs with max. bore

### Cylindrical bores

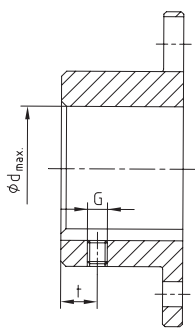

Standard hub 1.0 with feather keyway according to DIN 6885 sheet 1									
Size	d <sub>max.</sub>	G	t	T <sub>A</sub> [Nm]	Size	d <sub>max.</sub>	G	t	T <sub>A</sub> [Nm]
20	20	M5	6	2.0	105	110	M12	30	40.0
25	25	M5	8	2.0	115	120	M12	30	40.0
35	38	M6	15	4.8	135	135	-	-	-
38	42	M6	15	4.8	136 / 138	135	-	-	-
42	50	M8	20	10.0	156 / 158	150	-	-	-
50	55	M8	20	10.0	166 / 168	170	-	-	-
60	65	M8	20	10.0	186 / 188	190	-	-	-
70	75	M10	20	17.0	206 / 208	210	-	-	-
80	85	M10	20	17.0	246 / 248	245	-	-	-
85	90	M10	25	17.0	286 / 288	290	-	-	-
90	100	M12	25	40.0	336 / 338	340	-	-	-
							According to customer specification		

### Backlash-free shaft-hub connections without feather key

Selection: If used in potentially explosive atmospheres the clamping ring hubs must be selected in a way that there is a minimum safety factor of  $s = 2$  between the peak torque of the machine including all operating parameters and the nominal torque and frictional locking torque of the coupling.

Clamping ring hub type 6.5  
(clamping screws outside)

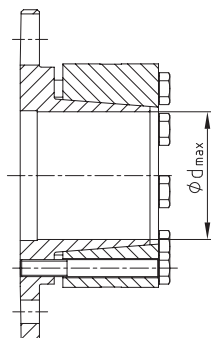

Clamping ring hub type 6.0  
(clamping screws inside)

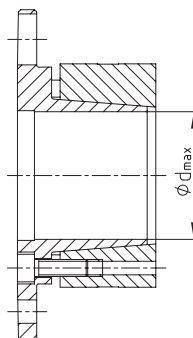

Type with CLAMPEX® element type 603

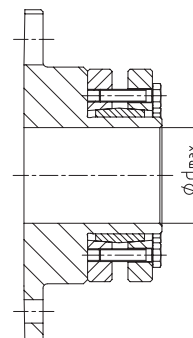

# RADEX®-N NN, NANA 1 and NANA 2 Steel lamina couplings

## Standard types



For legend of pictogram please refer to flapper on the cover

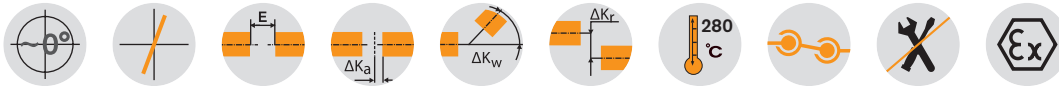

### Components

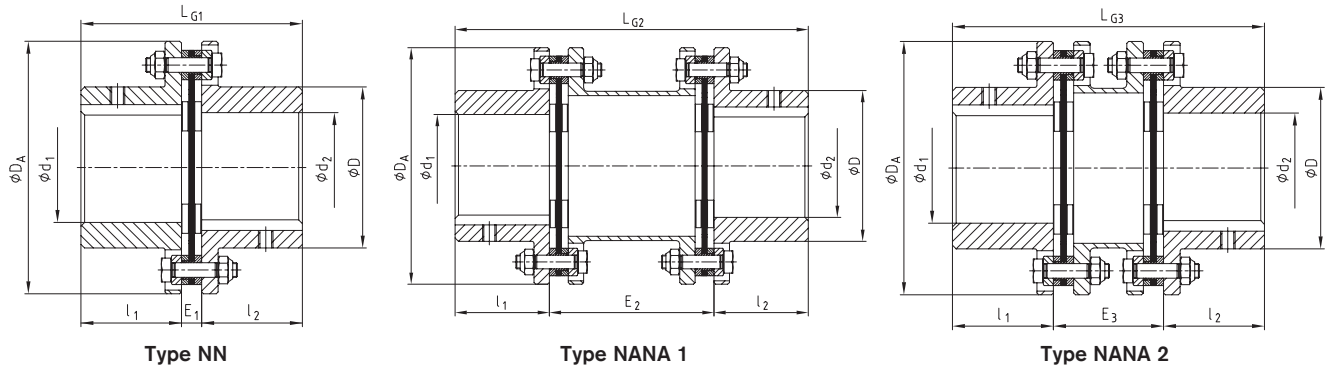

RADEX®-N Types NN, NANA 1, NANA 2										
Size	Max. finish bore		Dimensions [mm]							
	d <sub>1</sub> , d <sub>2</sub>	D	D <sub>A</sub>	l <sub>1</sub> , l <sub>2</sub>	L <sub>G1</sub>	E <sub>1</sub>	L <sub>G2</sub>	E <sub>2</sub>	L <sub>G3</sub>	E <sub>3</sub>
20	20	32	56	20	45	5	100	60	-	-
25	25	40	68	25	56	6	110	60	-	-
35	38	54	82	40	86	6	150	70	-	-
38	42	58	94	45	98	8	170	80	-	-
42	50	68	104	45	100	10	170	80	-	-
50	55	78	126	55	121	11	206	96	-	-
60	65	88	138	55	121	11	206	96	170	60
70	75	102	156	65	141	11	246	116	200	70
80	85	117	179	75	164	14	286	136	233	83
85	90	123	191	80	175	15	300	140	246	86
90	100	132	210	80	175	15	300	140	251	91
105	110	147	225	90	200	20	340	160	281	101
115	120	163	265	100	223	23	370	170	309	109
135	135	184	305	135	297	27	520	250	-	-
136	135	180	300	135	293	23				
156	150	195	325	150	327	27				
166	170	225	350	165	361	31				
186	190	250	380	185	401	31				
206	210	275	420	200	437	37				
246	245	320	500	240	524	44				
286	290	383	567	280	612	52				
336	340	445	660	330	718	58				
138	135	180	300	135	293	23				
158	150	195	325	150	327	27				
168	170	225	350	165	361	31				
188	190	250	380	185	401	31				
208	210	275	420	200	437	37				
248	245	320	500	240	524	44				
288	290	383	567	280	612	52				
338	340	445	660	330	718	58				

Ordering example:	RADEX®-N 60	NANA 1	Ø50	Ø60
	Coupling size	Type	Finish bore d <sub>1</sub>	Finish bore d <sub>2</sub>

Standard types



For legend of pictogram please refer to flapper on the cover

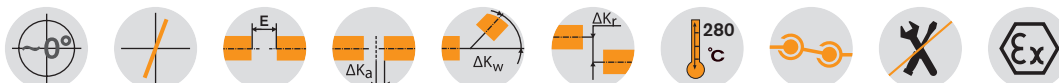

Components

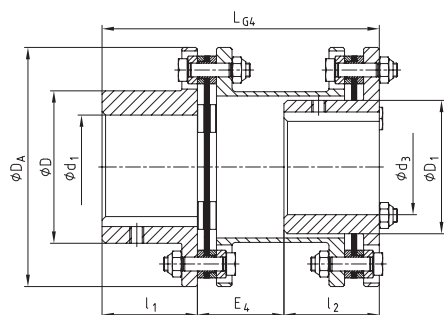

Type NENA 1

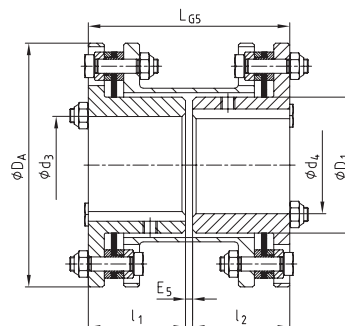

Type NENE 1

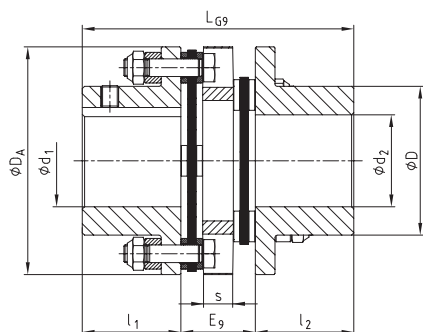

Type NNZ

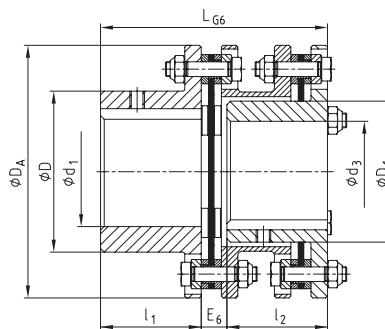

Type NENA 2

RADEX®-N Types NENA 1, NENE 1, NENA 2, NNZ

Size	Max. finish bore		Dimensions [mm]												
	d <sub>1</sub> , d <sub>2</sub>	d <sub>3</sub> , d <sub>4</sub>	D	D <sub>1</sub>	D <sub>A</sub>	l <sub>1</sub> , l <sub>2</sub>	LG <sub>4</sub>	E <sub>4</sub>	LG <sub>5</sub>	E <sub>5</sub>	LG <sub>6</sub>	E <sub>6</sub>	LG <sub>9</sub>	E <sub>9</sub>	
20	20	-	32	-	56	20	-	-	-	-	-	-	58	18	
25	25	-	40	-	68	25	-	-	-	-	-	-	70	20	
35	38	-	54	-	82	40	-	-	-	-	-	-	102	22	
38	42	-	58	-	94	45	-	-	-	-	-	-	118	28	
42	50	-	68	-	104	45	-	-	-	-	-	-	124	34	
50	55	-	78	-	126	55	-	-	-	-	-	-	144	34	
60	65	55	88	77	138	55	160	50	114	4	124	14	144	34	
70	75	65	102	90	156	65	190	60	134	4	144	14	166	36	
80	85	75	117	104	179	75	220	70	154	4	167	17	-	-	
85	90	80	123	112	191	80	232	72	164	4	178	18	-	-	
90	100	85	132	119	210	80	233	73	166	6	184	24	-	-	
105	110	90	147	128	225	90	263	83	186	6	204	24	-	-	
115	120	100	163	145	265	100	288	88	206	6	227	27	-	-	

Ordering example:

RADEX®-N 60	NENA 1	Ø50	Ø60
Coupling size	Type	Finish bore d <sub>1</sub>	Finish bore d <sub>2</sub>

# RADEX®-N NANA 4 and NNW Steel lamina couplings



## Customized types

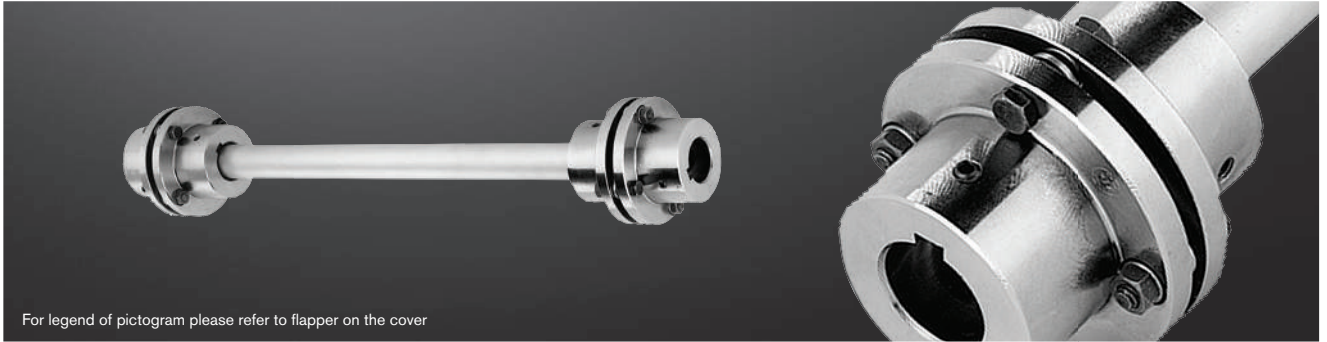

For legend of pictogram please refer to flapper on the cover

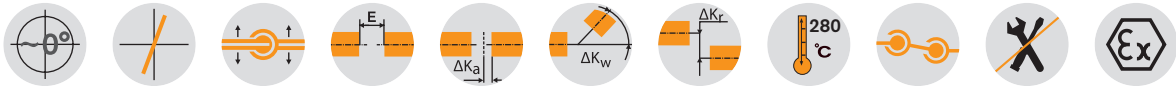

### Components

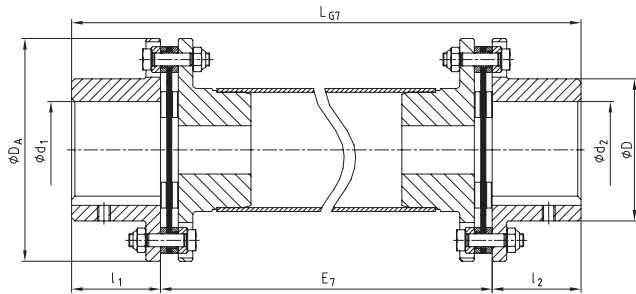

Type NANA 4

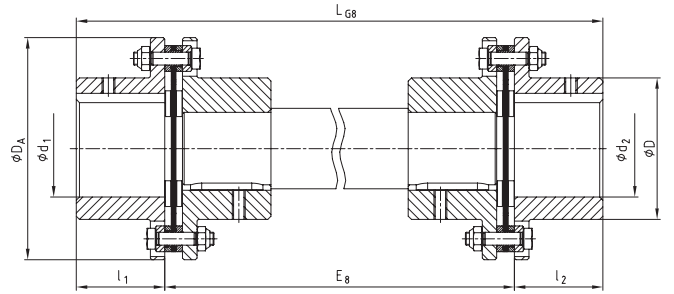

Type NNW

RADEX®-N Types NANA 4, NNZ and NNW								
Size	Max. finish bore	Dimensions [mm]						
	d <sub>1</sub> , d <sub>2</sub>	D	D <sub>A</sub>	l <sub>1</sub> , l <sub>2</sub>	LG7	E7	LG8	E8
20	20	32	56	20				
25	25	40	68	25				
35	38	54	82	40				
38	42	58	94	45				
42	50	68	104	45				
50	55	78	126	55				
60	65	88	138	55				
70	75	102	156	65				
80	85	117	179	75				
85	90	123	191	80				
90	100	132	210	80				
105	110	147	225	90				
115	120	163	265	100				
135	135	184	305	135				
136	135	180	300	135				
156	150	195	325	150				
166	170	225	350	165				
186	190	250	380	185				
206	210	275	420	200				
246	245	320	500	240				
286	290	383	567	280				
336	340	445	660	300				
138	135	180	300	135				
158	150	195	325	150				
168	170	225	350	165				
188	190	250	380	185				
208	210	275	420	200				
248	245	320	500	240				
288	290	383	567	280				
338	340	445	660	300				

**Ordering example:**

RADEX®-N 60	NANA 4	Ø50	Ø60	2500
Coupling size	Type	Finish bore d <sub>1</sub>	Finish bore d <sub>2</sub>	Shaft distance dimension

### Corrosion-resistant type for large shaft distances



For legend of pictogram please refer to flapper on the cover

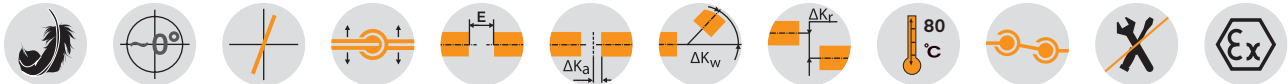

#### Components

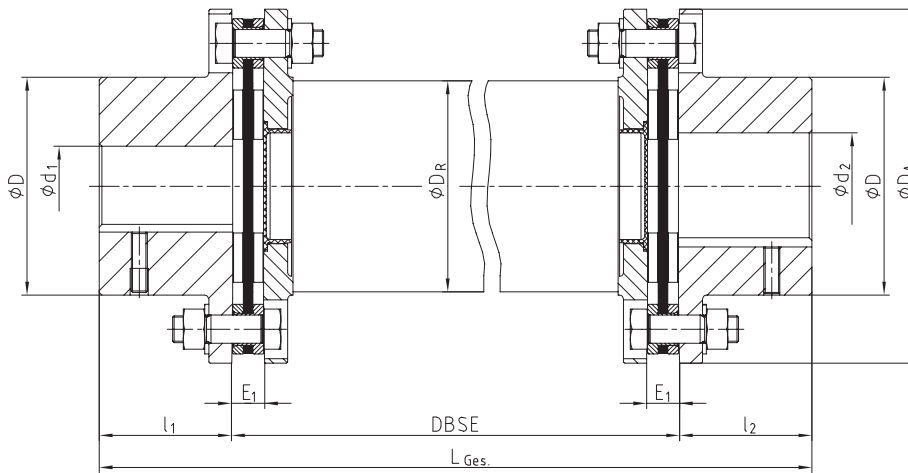

RADEX®-N Type NANA 4 CFK											
Size	Torque [Nm] <sup>1)</sup>		Dimensions [mm]								
	T <sub>KN</sub>	T <sub>K max</sub>	D <sub>A</sub>	d <sub>1</sub> , d <sub>2</sub> max.	D	l <sub>1</sub> , l <sub>2</sub>	E <sub>1</sub>	DBSE	L <sub>total</sub>	Composite tube D <sub>R</sub>	Max. DBSE <sup>2)</sup> with 1500 rpm
70	800	1600	149	75	102	65	11	As specified by the customer	l <sub>1</sub> + l <sub>2</sub> + DBSE	95	3500
85	1800	3600	184	90	123	80	15			117	3900
90	2500	5000	200	100	135	80	15			128	4100
115	4500	9000	253	120	163	100	23			160	4600

<sup>1)</sup> For selection of coupling see page 18 et seqq.

<sup>2)</sup> For higher speeds or bigger shaft distance dimensions please consult with KTR's engineering department (+49 5971 798-484). The above-mentioned characteristic figures (e. g. max. DBSE) can be varied by composite tubes optimized for the application, if necessary.

Particularly the steel lamina couplings are well suited for applications with especially large distance dimensions between the drive and the driven side (e. g. cooling towers, fans etc.) due to their design. In order to be able to generate high speeds with large distance dimensions, RADEX®-N couplings with intermediate shafts made of glass fiber or carbon fiber reinforced nylon (GRP or CFRP) are used, if necessary.

#### Ordering example:

RADEX®-N 85	NANA 4 CFK	Ø60	Ø70	3000
Coupling size	Type	Finish bore d <sub>1</sub>	Finish bore d <sub>2</sub>	Shaft distance dimension



# RADEX®-N NANA 3

## Steel lamina couplings

Pump drives in accordance with API 610



For legend of pictogram please refer to flapper on the cover

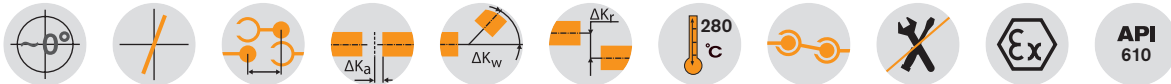

RADEX®-N Type NANA 3							
Size	Max. finish bore	Dimensions [mm]				Perm. displacements	
	d	D	DA	E <sup>Standard</sup> <sup>1)</sup>	l <sub>1</sub> , l <sub>2</sub>	Angular [°] each lamina	Axial [mm]
42	50	68	104	100	45	1.0	2.8
50	55	78	126	140/180	55	1.0	3.2
60	65	88	138	100/140/180/250	55	1.0	2.0
70	75	102	156	100/140/180	65	1.0	2.2
80	85	117	179	100/140/180/250	75	1.0	2.6
85	90	123	191	100/140/180/250	80	1.0	2.3
90	100	132	210	140/180/250	80	1.0	2.0
105	110	147	225	250	90	1.0	2.4
115	120	163	265	250	100	1.0	2.8
135	135	184	305	250	135	1.0	3.5
136	135	180	300		135	0.7	3.7
156	150	195	325		150	0.7	4.2
166	170	225	350		165	0.7	4.5
186	190	250	380		185	0.7	4.8
206	210	275	420		200	0.7	5.2
246	245	320	500		240	0.7	6.0
286	290	383	567		280	0.7	6.7
336	340	445	660		330	0.7	7.5
138	135	180	300	As specified by the customer	135	0.5	2.6
158	150	195	325		150	0.5	2.8
168	170	225	350		165	0.5	3.0
188	190	250	380		185	0.5	3.2
208	210	275	420		200	0.5	3.5
248	245	320	500		240	0.5	4.0
288	290	383	567		280	0.5	4.5
338	340	445	660		330	0.5	5.0

<sup>1)</sup> Other distance dimensions E available on request.

Ordering example:	RADEX®-N 60	NANA 3	Ø50	Ø60	140
	Coupling size	Type	Finish bore d <sub>1</sub>	Finish bore d <sub>2</sub>	Shaft distance dimension

## Components

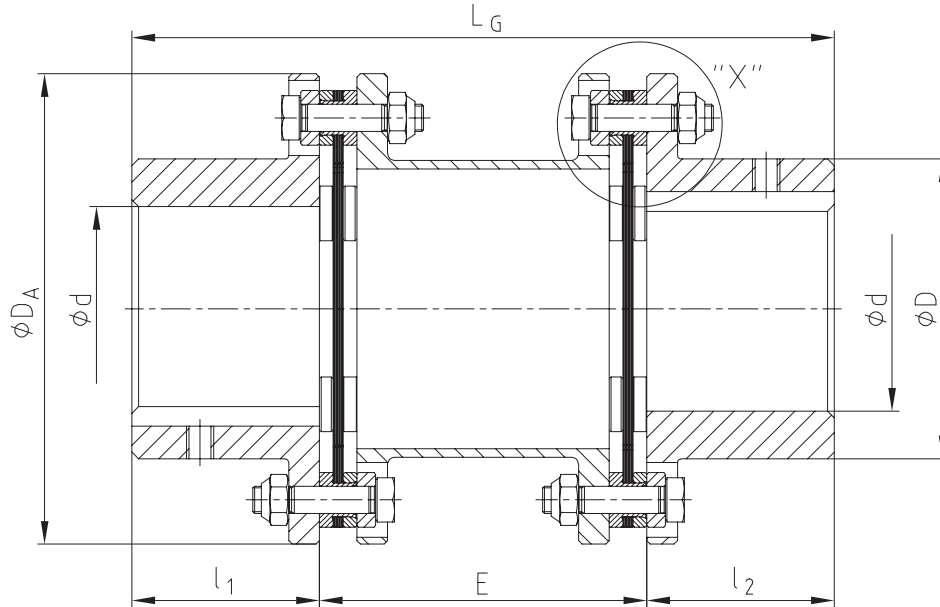

### Detail "X"

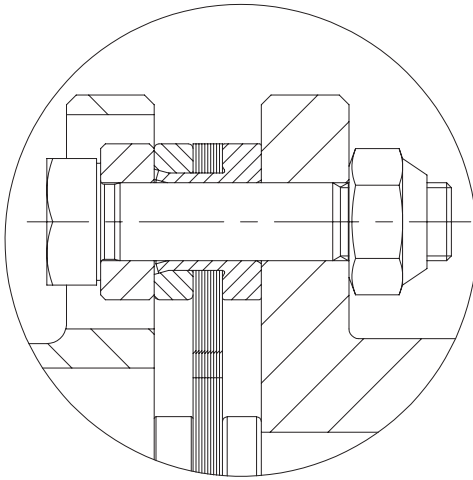

Safety catch of the spacer:  
The lamina sets are provided with a sleeve in order to fasten the spacer if the laminas break.

Any questions? Please contact us.



**Morskate®**



Any questions? Please contact us.

**Morskate Aandrijvingen BV**

Oosterveldsingel 47A  
7558 PJ Hengelo (Ov)  
The Netherlands

NL

T +31 (0)74 - 760 11 11  
info@morskateaandrijvingen.nl  
www.morskateaandrijvingen.nl

DE

T +49 692 - 222 34 95  
info@morskateantriebstechnik.de  
www.morskateantriebstechnik.de

EN

T +31 (0)74 - 760 11 11  
info@morskatedrivetechnology.com  
www.morskatedrivetechnology.com