

TORQUE LIMITER SERIES 600

Airjustor®

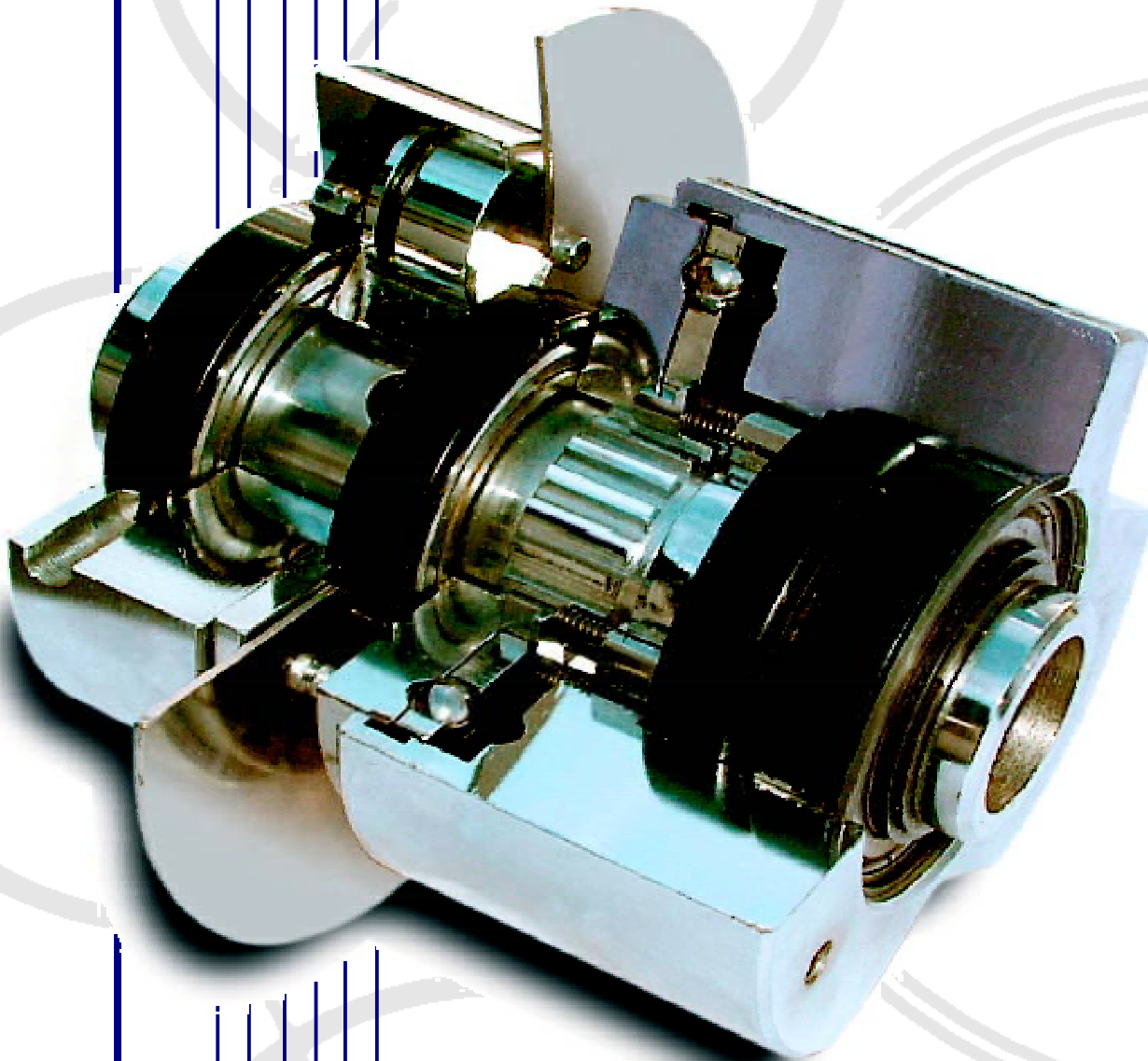

Any questions? Please contact us.

Morskate Aandrijvingen BV

Oosterveldsingel 47A
7558 PJ Hengelo (Ov)
The Netherlands

NL

T +31 (0)74 - 760 11 11
info@morskateaandrijvingen.nl
www.morskateaandrijvingen.nl

DE

T +49 692 - 222 34 95
info@morskateantriebstechnik.de
www.morskateantriebstechnik.de

EN

T +31 (0)74 - 760 11 11
info@morskatedrivetechnology.com
www.morskatedrivetechnology.com

AUTOGARD SERIES 600

Quality and Autogard are synonymous with overload protection. The Company's reputation for high quality products is derived from over 40 years of design, innovation and production. Autogard products are manufactured to meet ISO 9001 using the latest machine tools and high quality materials.

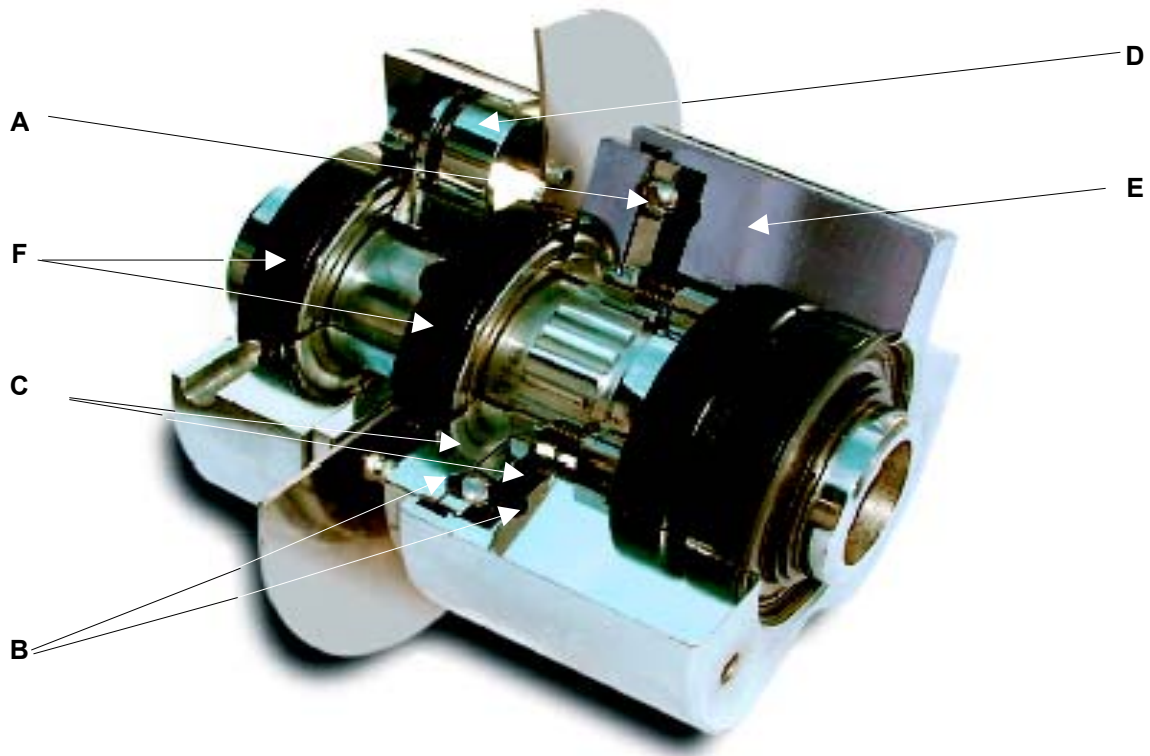

The drive is transmitted through balls 'A' held in detents 'B' in opposing plates 'C' by adjustable air pressure acting on a large annular piston or a number of small pistons depending on the torque required.

The air cylinder / piston assembly 'D' is separated from the rotating drive plate / adapter 'E' and plates by two deep groove ball bearings 'F'. This allows air to be supplied radially for shaft to shaft and line shaft applications and gives a long maintenance free life.

As a Disengaging Clutch

When required to act as a disengaging clutch, the air is dumped at the press of a button, the balls roll out of their seating, the plates are held apart by spring pressure so that no drive is transmitted by the coupling. Two more ball bearings are provided between the hub and main drive plate / adapter to give a completely free running clutch.

As a Torque Limiter

The overload protection for the drive is provided by the same mechanism. The supply air pressure may be set in the range 1.35 - 5.4 Bar (20-80 psi) to give the precise overload torque requirement using a pressure regulator. This can be done manually during normal running to take account of changing loads, or automatically using a dual regulator system with a timer or other control. This allows high start torque to be accommodated before switching to a lower running torque. When the torque setting is exceeded, the balls begin to roll out of their seating, forcing plates apart against the air pressure. This motion operates a pneumatic limit switch which 'dumps' the air pressure, disengages the clutch and releasing the drive from the overloaded machine.

Re-engagement is effected in both cases simply by operating a Push Button Initiating Valve. Rotation of the drive at slow speed will then engage the clutch.

The specifications contained within this brochure are correct at the time of going to print. Autogard is continually reviewing and updating the specifications on all its product ranges and therefore reserves the right to change any details.

AUTOGARD SERIES 600

No other torque limiter can match Autogard's versatility, accuracy and reliability. The ability to accommodate starting torque means it can be fitted in almost any position in the drive. The final choice should take into account of the requirements for isolating parts of the drive and the position of large inertia loads.

Features and Benefits

The Autogard Series 600 Airjustor is a pneumatically controlled, combined torque limiter and disengaging clutch which offers the power transmission engineer a host of drive control options, including:-

Sensitive and accurate torque limitation with free running disengagement. The disengaging torque can be varied whilst the drive is running using an air regulator.

A drive disconnect feature which allows machine cleaning and maintenance, standby drives and optional machine mechanisms to be engaged as required and a host of other advantages.

A higher 'starting' torque which can be transmitted to accelerate the machine, dropping to a lower 'running' torque once up to speed. Optimum sensitivity is thus achieved whilst avoiding the dangers encountered with start up 'lock-out' type torque limiters.

Rolling disengagement with no ball skidding, giving the Airjustor high sensitivity, repeatability and longer life.

Synchronous reset at the touch of a button at slow speeds, maintaining a direct angular relationship between driving and driven shafts.

Air pressure regulation which can be adjusted either manually for infrequent changes or automatically using pneumatic control systems.

Flexible coupling, sprocket and pulley models incorporating a drive adapter. This can be machined to mount a wide variety of drive components such as universal joints, machine elements, etc.

Selection

Data required for torque limiter selection.

- Kilowatt or Horsepower and rpm of the driver
- Shaft details for the driving and driven equipment

(1) Calculate the nominal torque:

$$\text{Torque (Nm)} = \text{Kilowatt (kW)} \times 9550 / \text{rpm} \quad \text{or}$$

$$\text{Torque (lbf-ins)} = \text{Horsepower (HP)} \times 63025 / \text{rpm}$$

Consideration should then be given to starting torque, particularly if the Airjustor is to be positioned close to the motor. This may be up to three times the normal running torque, and can be accommodated by the "In-motion" control facility.

(2) From the table below choose the size of unit for the torque calculated. Ensure that the torque range is sufficient to meet expected adjustments.

Size	Max. Bore (mm)	Type of Piston	Torque Range* (Nm)
0	16	8 Pistons	7 - 28
		4 Pistons	3.5 - 14
1	22	8 Pistons	28 - 130
		4 Pistons	14 - 56
2	32	8 Pistons	85 - 340
		4 Pistons	42 - 170
3	40	Annular Piston	170 - 680
		6 Pistons †	85 - 340
4	52	Annular Piston	288 - 1150
		8 Pistons †	144 - 575
5	80	Annular Piston	710 - 2840
		8 Pistons †	300 - 1200

* Minimum torque is 25% of maximum torque for any given piston combination assuming air supply at 1.35 - 5.4 Bar (20 - 80 psi)

† This number of pistons may be halved by blanking the air supply hole to alternate pistons giving half the maximum and minimum torques shown.

(3) Check limiting conditions:

- Check hub bore capacity
- Check the torque limiter dimensions such as the overall length and outside diameter.

(4) Select and specify the appropriate drive medium or coupling

Ordering the Series 600 Torque Limiter

When ordering please provide the following designation

Model / Type / Size / Piston / S1 Bore / S2 Bore

Feature: R - Automatic Rapid Reset (Standard)
T - Automatic Synchronous Reset (Optional)

Piston: MP - Multi-piston
AP - Annular piston

Example: 605 / T / 5 / MP4 / S1 45 mm / S2 40 mm

Refers to a model 605 size 5 Torque Limiter designed for Synchronous Reset with 4 multi-pistons

Bore S1 = 45 mm Bore S2 = 40 mm

S1 Bore & S2 Bore - Please specify metric or imperial.
Standard bore tolerance H8 with normal fit key Js9

AUTOGARD SERIES 600

MODEL 602

For use with sprockets, pulleys or gears.

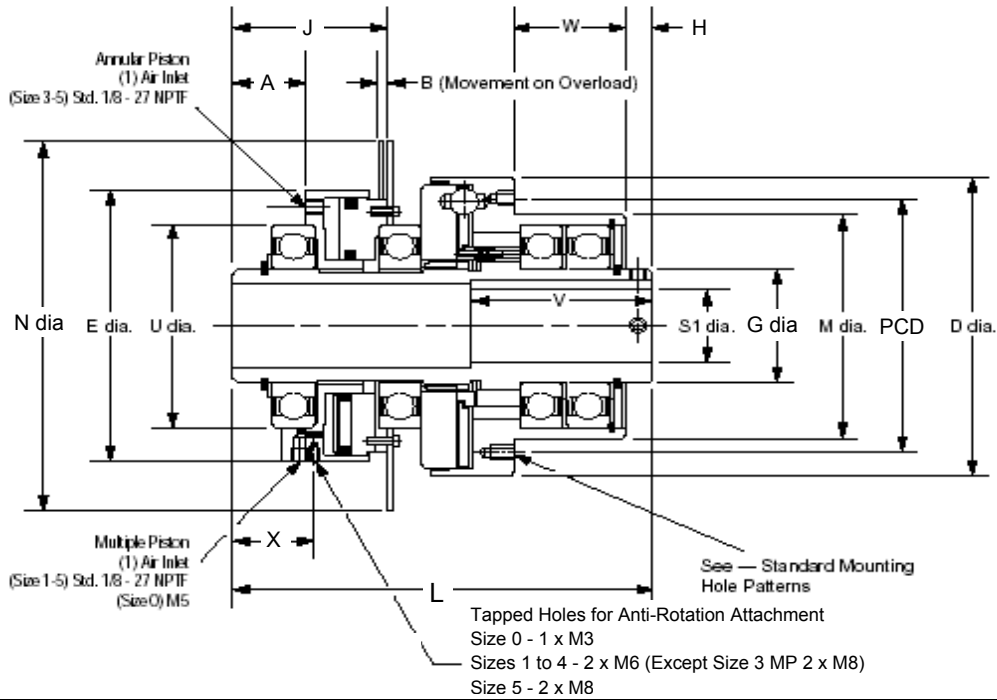

Technical Data

Size	0		1		2		3		4		5		
	MP	AP	MP	AP	MP	AP	MP	AP	MP	AP	MP	AP	
Torque Nm ①	Max		28	130	340	340	680	575	1150	1200	2840		
	Min		3.5	14	42	43	170	72	288	150	710		
Speed rpm ②	Max		1000	1000	500	500	500	500	500				
Weight Kg ③			2	5.4	10.3	16.3	27.8						
Mass Moment of inertia Kgm ² ③			0.001	0.003	0.008	0.024	0.064			0.25	0.301		

- 1) For higher torque applications please consult Autogard.
- 2) Higher speeds may be allowed under certain conditions. Please consult Autogard
- 3) Weights and moments of inertia apply to maximum bore (S1).

Dimensional Data - mm

Size	0		1		2		3		4		5				
	MP	AP	MP	AP	MP	AP	MP	AP	MP	AP	MP	AP			
Max. Bore S1 ④	16		22		32		40		52		80				
A	17		16		17		22		42		46		56		
D	70		102		134		152		159		184		255		
E	65		98		129		152		143		159		168	230	245
G	25		35		45		55		70		105				
H	8		8		10		10		12		15				
J	44		55		70		80		78		80		88	135	130
L	116		146		165		195		235		310				
M ⑤	52		70		85		110		140		180		210		
N	95		140		180		200		220		305				
U	47		62		75		100		125		160		190		
W	20		30		33		43		59		75				
X	30		40		25		32		37		53		47	75	53
Standard Mounting Hole Pattern	PCD		60		82		100		125		160		210		230
	No. & Size of Dowels		6 - 3		6 - 4		6 - 5		6 - 6		6 - 8		6 - 10		
No. & Size of Holes		3 - M3		3 - M4		3 - M5		3 - M6		3 - M8		3 - M8			
B ⑥	2.4		4.0		6.0		6.0		7.7		8.5				

Smallest Sprocket (No. of teeth)	3/8 ins. pitch	26	34	41	50	62	-	-
	1/2 ins. pitch	20	27	31	38	48	60	65
	5/8 ins. pitch	17	22	26	31	39	49	53
	3/4 ins. pitch	-	-	22	27	33	41	44
	1 ins. pitch	-	-	17	21	25	32	34
Smallest Pulley Diameter (mm) ⑦		68	94	112	140	180	228	248

- 4) For sizes 2 and above when using maximum bores, use rectangular parallel keys
- 5) Tolerance for diameter M is k7
- 6) Movement on disengagement
- 7) The diameter quoted is to the bottom of a V pulley groove or the ID of the flange on a timing pulley

AUTOGARD SERIES 600

MODEL 605

Design including the Autogard Autoflex EB torsionally rigid metal membrane coupling for angular misalignment. The Autogard Autoflex ES coupling can also be supplied which accommodates angular and parallel offset misalignment.

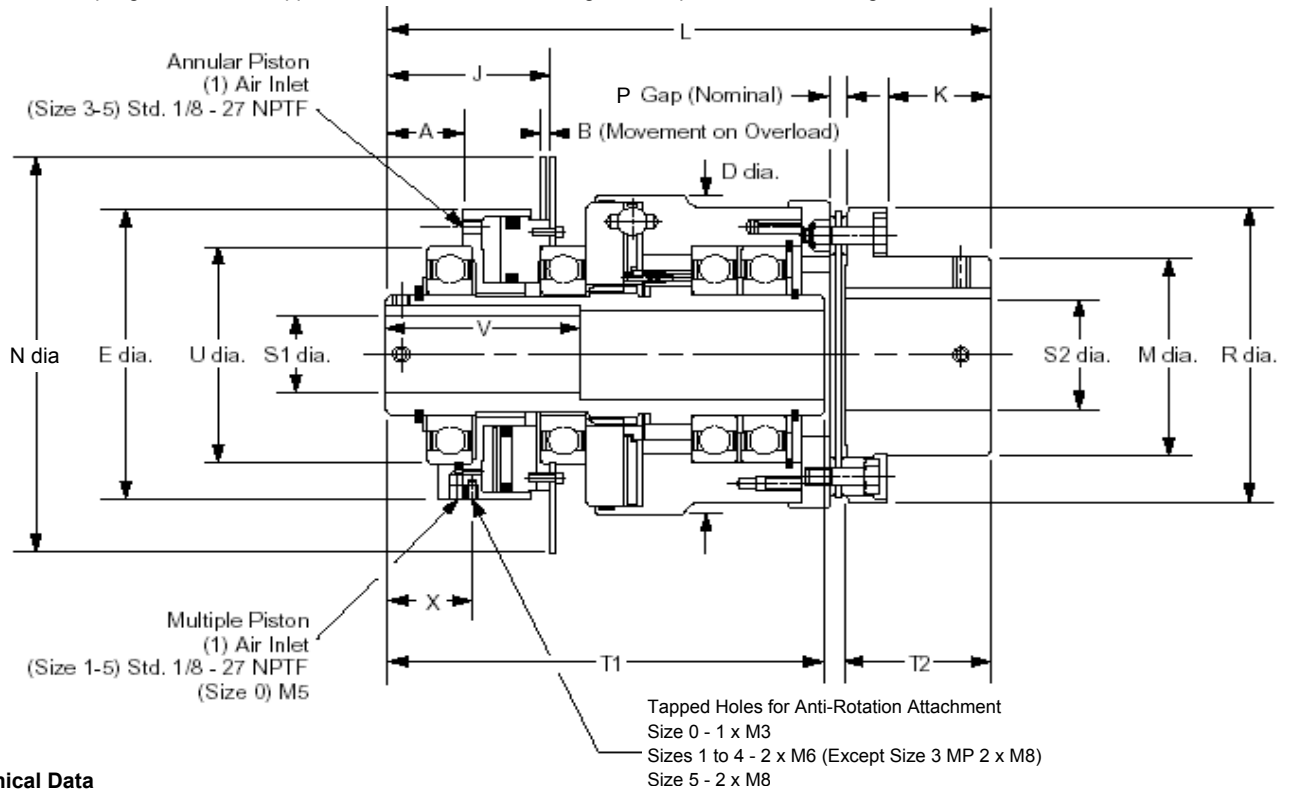

Technical Data

Size			0 / 8HVII	1 / 35HVII	2 / 70HVII	3 / 150HVII		4 / 150HVII		5 / 480HVII	
						MP	AP	MP	AP	MP	AP
Torque	Nm ①	Max	28	130	340	340	680	575	1150	1200	2840
		Min	3.5	14	42	43	170	72	288	150	710
Speed	rpm ②	Max	1000	1000	500	500		500		500	
Weight	Kg ③		3.4	8.7	15.7	27.2		40.5		110	
Mass Moment of inertia	Kgm ² ③		0.0016	0.008	0.019	0.059		0.111		0.608	0.602
Max Coupling	Axial (mm)		0.3	0.49	0.56	0.74		0.74		1.0	
Misalignments	Angular (°)		½	½	½	½		½		½	

- 1) For higher torque applications please consult Autogard.
- 2) Higher speeds may be allowed under certain conditions. Please consult Autogard
- 3) Weights and moments of inertia apply to maximum bores (S1 & S2).

Dimensional Data - mm

Size			0 / 8HVII	1 / 35HVII	2 / 70HVII	3 / 150HVII		4 / 150HVII		5 / 480HVII	
						MP	AP	MP	AP	MP	AP
Max. Bore S1		④	16	22	32	40		52		80	
Max. Bore S2		④	30	50	66	90		90		110	
A			17	16	17	22	42	40	48	46	56
D			70	102	134	159		184		255	
E			65	98	129	152	143	168	168	230	245
J			44	55	70	80	78	80	88	135	130
K			23	33	45	59		59		75	
L			167	195	225	270		331		454	
M			44	71	91	123		123		150	
N			95	140	180	200		220		305	
P (nominal gap)			7.4	9.4	9.4	8.8		8.8		15	
R			80	110	133	170		170		230	
T1			116	142	162	190		235		305	
T2			33	46	58	75		75		95	
U			47	62	75	100		125		160	190
V			57	76	89	95		133		159	
X			30	40	25	32	37	53	47	75	53
B		⑤	2.4	4	6	6		7.7		8.5	

- 4) For maximum bores greater than 25 mm use rectangular parallel keys.
- 5) Movement on disengagement

AUTOGARD SERIES 600

MODEL 606N

Design including a torsionally soft flexible coupling for parallel and angular misalignment

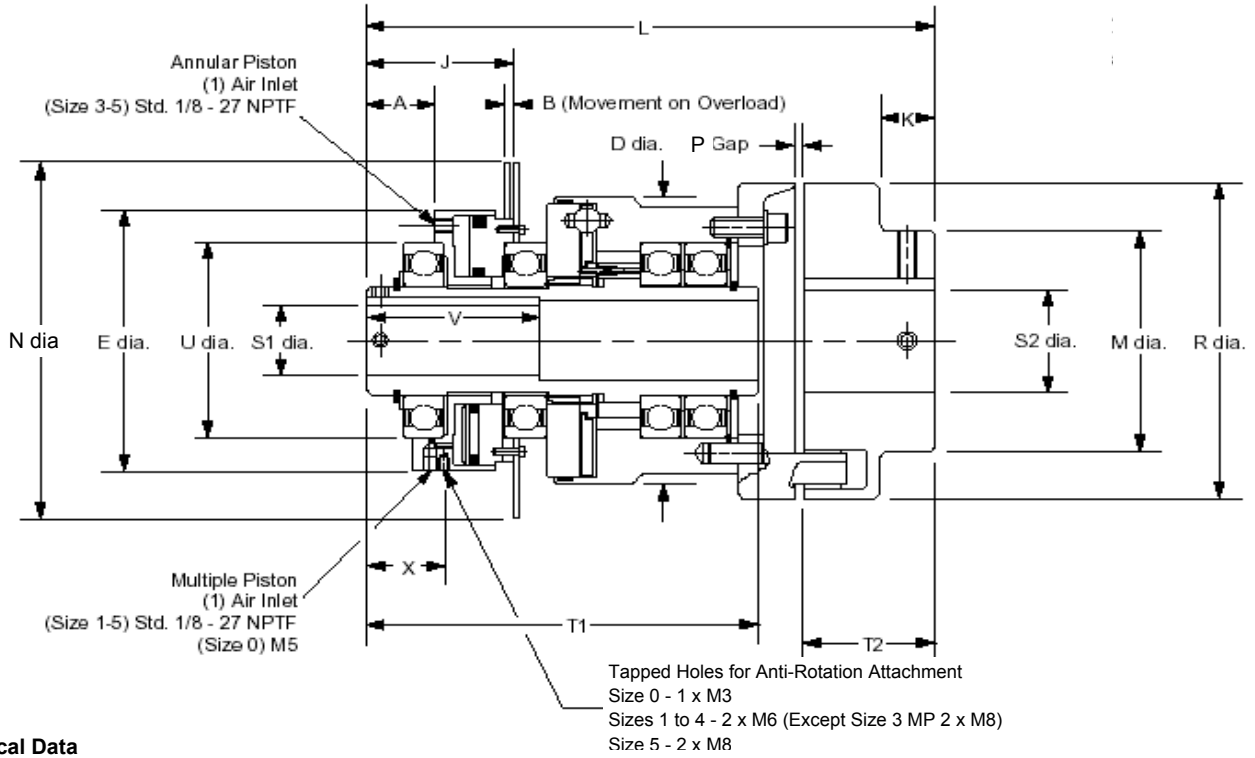

Technical Data

Size			0 / 68	1 / 110	2 / 125	3 / 160		4 / 200		5 / 250	
						MP	AP	MP	AP	MP	AP
Torque	Nm ①	Max	28	130	340	340	680	575	1150	1200	2840
		Min	3.5	14	42	43	170	72	288	150	710
Speed	rpm ②	Max	1000	1000	500	500	500	500	500	500	500
Weight	Kg ③		2.9	9.9	15.6	24.9	48.4	112			
Mass Moment of inertia	Kgm ² ③		0.0011	0.009	0.019	0.051	0.15	0.655	0.648		
Max Coupling	Axial (mm)		2	2	2	4	4	5			
Misalignments	Parallel (mm)		0.13	0.18	0.2	0.28	0.33	0.43			
	Angular (°)		0.09	0.09	0.1	0.1	0.1	0.1			

- 1) For higher torque applications please consult Autogard.
- 2) Higher speeds may be allowed under certain conditions. Please consult Autogard
- 3) Weights and moments of inertia apply to maximum bores (S1 & S2).

Dimensional Data - mm

Size		0 / 68	1 / 110	2 / 125	3 / 160		4 / 200		5 / 250	
					MP	AP	MP	AP	MP	AP
Max. Bore S1	④	16	22	32	40	52	80			
Max. Bore S2	④	24	48	55	65	85	100			
A		17	16	17	22	42	40	48	46	56
D		70	102	134	159	184	255			
E		65	98	129	152	143	168	168	230	245
J		44	55	70	80	78	80	88	135	130
K		-	13	19	21	33	40			
L		140	202	235	280	340	448			
M		-	78	90	108	140	165			
N		95	140	180	200	220	305			
P (nominal gap)		3	3	3	4	4	5.5			
R		68	110	125	160	200	250			
T1		116	142	162	190	235	305			
T2		20	40	50	60	80	100			
U		47	62	75	100	125	160	190		
V		57	76	89	95	133	159			
X		30	40	25	32	37	53	47	75	53
B	⑤	2.4	4	6	6	7.7	8.5			

- 4) For maximum bores greater than 25 mm use rectangular parallel keys.
- 5) Movement on disengagement

AUTOGARD SERIES 600

GENERAL INFORMATION

Graphs plotting torque (Nm) against air pressure for each size.

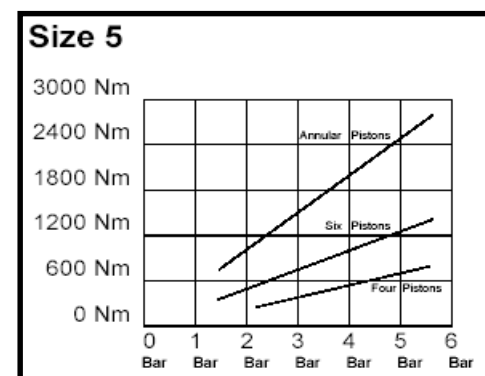
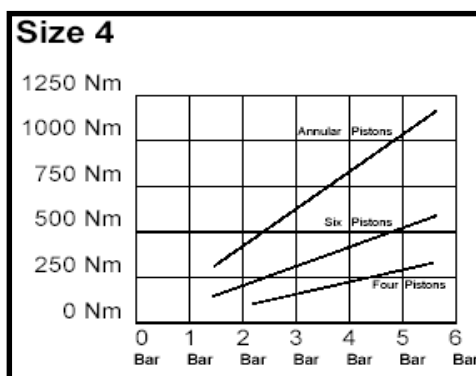
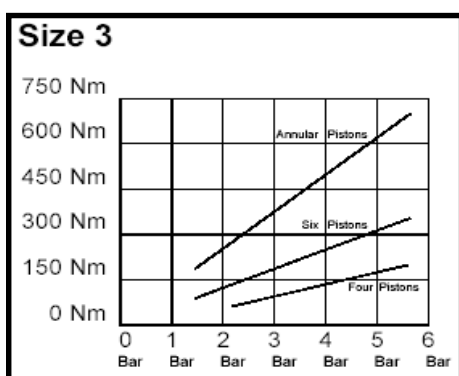
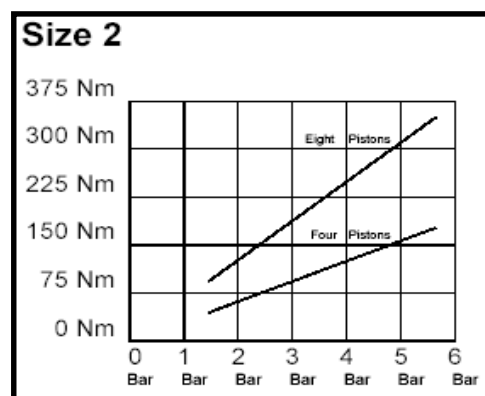
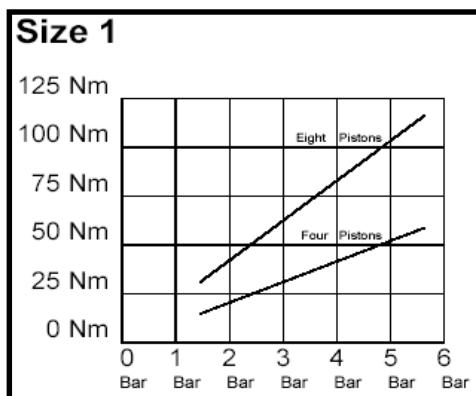
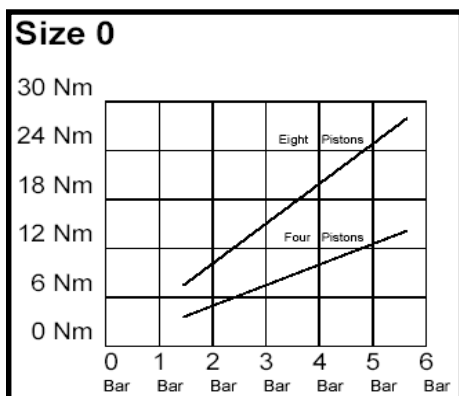

Maintenance

The Autogard torque limiter uses journal and needle thrust bearings. The latter are packed with grease on assembly as are the driving balls. Under reasonably clean conditions the unit will operate with a minimum of maintenance and re-lubrication. The frequency of maintenance is dependant on many operating factors, but in adverse conditions please consult Autogard.

Pneumatic Controls.

This suggested system permits simple torque adjustment of the Airjuster. The torque may be varied from 25% of the maximum torque to maximum torque of the piston configuration used (that is 1.35 - 5.4 Bar or 20 - 80 psi). This can be accomplished either when the drive is stationary or 'In-motion'

The use of a quick exhaust valve is strongly recommended to aid disengagement.

Protective Finish

The standard finish provides a high level of corrosive resistance. Units can be supplied with a suitable alternative finish for special machinery requirements, or for adverse environmental conditions. Please consult Autogard to discuss special requirements.

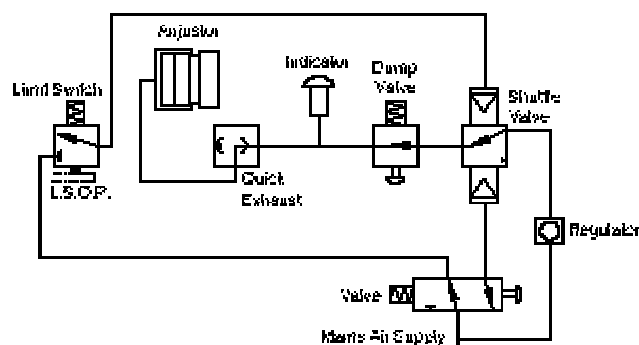

General Safety

The Autogard Torque Limiter is a reliable unit, built to high standards of workmanship. Similar to all mechanical devices, each application must be considered on its own merits with reference to safety (i.e. lifting equipment, explosive conditions, etc.). As a rotating component, adequate guarding must be provided, in accordance with local codes. Autogard staff are always available to discuss particular applications.

Any questions? Please contact us.

Morskate Aandrijvingen BV
Oosterveldsingel 47A
7558 PJ Hengelo (Ov)
The Netherlands

NL
T +31 (0)74 - 760 11 11
info@morskateaanrijvingen.nl
www.morskateaanrijvingen.nl

DE
T +49 692 - 222 34 95
info@morskateantriebstechnik.de
www.morskateantriebstechnik.de

EN
T +31 (0)74 - 760 11 11
info@morskatedrivetechnology.com
www.morskatedrivetechnology.com